

ODISHA CONSTRUCTION CORPORATION LIMITED
(A GOVT. OF ODISHA UNDERTAKING)
CENTRAL WORKSHOP, RASULGARH,
BHUBANESWAR-751010 (ODISHA)

* * * * *

TENDER DOCUMENT FOR

“ Supply of casting items in finished condition i.e., Driving wheel, wheel gear, Driven wheel, Idler Gear, Pinion, driving wheel bush, idler Gear bush, wheel spacer, Driven wheel bush, Spacer, Washer, idler Gear, Wheel Spacer, Washer, housing , Helical spring for long travel mechanism of 35T gantry crane of Telengiri Irrigation Project ”

The tender document comprises of the following:

- | | | |
|----|---|-----------------------|
| 1) | Tender call notice No. OCC/CWS/PROC/ TIP-08(V-II)/
12/2026-27 dated.11.06.2026 | 01 (One) sheet |
| 2) | Terms and conditions | 04 (Four) sheets |
| 3) | Drawings | 17 (Seventeen) sheets |
| 4) | Price schedule | 02 (Two) sheet |

Total : 24 (Twenty four) sheets

**Signature of the tenderer or his/their
power of attorney holder
with designation & seal.**

**Senior Manager (Mech.)-I
OCC Ltd, Central Workshop,
Rasulgarh, Bhubaneswar-751010**

ODISHA CONSTRUCTION CORPORATION LIMITED
(A GOVT. OF ODISHA UNDERTAKING)
CENTRAL WORKSHOP, RASULGARH,
BHUBANESWAR-751010 (ODISHA)

TENDER CALL NOTICE No. OCC/CWS/PROC/ TIP-08)V-II) /12 /2026-27 dated.11.06.2026

Sealed Tender (through Speed Post) / (through Password protected email) in conformity with the terms & conditions are invited from the reputed manufacturers / Trader / Supplier for “**Supply of casting items in finished condition i.e., Driving wheel, wheel gear, Driven wheel, Idler Gear, Pinion, driving wheel bush, idler Gear bush, wheel spacer, Driven wheel bush, Spacer, Washer, idler Gear, Wheel Spacer, Washer, housing , Helical spring for long travel mechanism of 35T gantry crane of Telengiri Irrigation Project** ” as per details below:

Cost of tender document (Non-refundable)	Sale of tender document		Earnest money deposit (EMD) required	Receipt of tender	Opening of Technical & price bid of tender
Rs. 6000/- GST @ 18% Rs.7080/- by hand & Rs.7180/- by Regd. Post/ courier	From 13.06.2026	To 20.06.2026 up to 1.00 PM	1(One)% of the total quoted value including GST	Up to 3.30 P.M. on 20.06.2026	At 4.00 PM on 20.06.2026

- Tender document can be purchased by the interested reputed manufacturers / Trader / Supplier by hand from the office of the undersigned on payment of cost of tender document i.e. **Rs.6000/-** + GST @ 18% amounting to **Rs.7080/-** in cash or in shape of A/c. payee demand draft on any Nationalised Bank / Scheduled Bank payable at Bhubaneswar (Non-refundable) drawn in favour of “**Odisha Construction Corporation Limited - Project Account**” and on production of attested copies of the following documents and verification thereof by the undersigned.
 - Valid GST Registration Certificate.
 - PAN Card.
- The tender document can also be obtained by the interested reputed manufacturers by Speed Post on sending the cost of tender document i.e. **Rs.6000/-** + GST @ 18% and postage charges of **Rs.100/-** amounting to **Rs.7180/-** in shape of A/c. payee demand draft drawn on any Nationalised Bank / Scheduled Bank payable at Bhubaneswar (Non-refundable) drawn in favour of “**Odisha Construction Corporation Limited - Project Account**” and on production of attested copies of the following documents and verification thereof by the undersigned.
- The tender document can also be downloaded from our Website www.odishaconstruction.com to submit the tender .
- The tender document should be submitted only through Speed Post along with the following self attested hard copies / Email along with the following self attested scan copies mail ID (smcwsoccltender@gmail.com) within stipulated date and time . The undersigned will not be responsible for any kind of delay by the postal authorities or any technical issue of website.
 - Valid GST Registration Certificate.
 - PAN Card.
 - Tenderer should submit valid manufacturer certificate / Trader License.
 - The Bidder has to submit copies of purchase orders, credentials, certificates etc. in support of supply of similar items of similar magnitude(in total) in last 5 financial years (i.e. from financial year 2020-21 to 2024-25 including current financial year 2025-26).
 -
- Bidders are requested to visit OCCL website regularly for addendum and corrigendum since any changes will not be published in news paper.

However, the cost of tender document i.e **Rs.6000/-** plus GST @ 18% amounting to **Rs.7080/-** in shape of A/c payee demand draft as stated above in favour of “**Odisha Construction Corporation Limited**” - **Project Account** on any Nationalised Bank/ Scheduled Bank payable at Bhubaneswar (Non-refundable) along with attested photo copies of all above documents should be submitted while submitting the tender in Envelope-I. Otherwise, the offer shall not be considered and OCCL will not be responsible for missing of any page while downloading. If there will be a public holiday on the last date of sale of tender document and receipt & opening of the tender as specified above, the tender document will be sold and tender will be received & opened on the next working day at the same time and venue.

Contd.

The SSI/NSIC/MSME units participating in tender are not entitled for exemption from payment of EMD/ Security Deposits/ Tender Paper costs as communicated vide DOWR Letter No. IIM-24/2018-14318/WR dated 24.05.2018 & Head Office, OCCL Letter No.5502/OCC/ CW-02/09(Vol-V)(WE) dated 30.05.2018.

The tenders will be opened in the presence of the tenderers or their authorised representatives. Tender through Fax/Telex/telegram will not be accepted

The undersigned reserves the right to accept or reject any or all tenders without assigning any reason thereof

**Signature of the tenderer or his/their
power of attorney holder
with designation & seal.**

**Senior Manager (Mech.)-I
OCC Ltd, Central Workshop,
Rasulgarh, Bhubaneswar-751010**

ODISHA CONSTRUCTION CORPORATION LIMITED

(A GOVT. OF ODISHA UNDERTAKING)

CENTRAL WORKSHOP, RASULGARH,

BHUBANESWAR-751010 (ODISHA)

TERMS AND CONDITIONS OF TENDER FOR

“ Supply of casting items in finished condition i.e., Driving wheel, wheel gear, Driven wheel, Idler Gear, Pinion, driving wheel bush, idler Gear bush, wheel spacer, Driven wheel bush, Spacer, Washer, idler Gear, Wheel Spacer, Washer, housing , Helical spring for long travel mechanism of 35T gantry crane of Telengiri Irrigation Project”

1. Reputed manufacturers / Trader / Supplier having supplied similar item of similar magnitude earlier and satisfactorily accepted by the clients will be eligible to participate in the tender. The copies of purchase orders, credentials, certificates etc. in support of similar supply and satisfactory performance thereof shall be furnished along with the tender.
2. The tenderer should submit Earnest Money Deposit (EMD) @ 1(One)% of the total quoted value along with the tender in shape of A/C payee Demand Draft drawn in favour of “Odisha Construction Corporation Limited” - Project Account on any Nationalised Bank / Scheduled bank payable at Bhubaneswar. The tenders received without EMD will be out rightly rejected. EMD of the unsuccessful tenderers will be released only after finalization of the tender.
3. For submission of tender through Speed Post, the outer cover should be sealed and subscribe in bold letters as “ **Supply of casting items in finished condition i.e., Driving wheel, wheel gear, Driven wheel, Idler Gear, Pinion, driving wheel bush, idler Gear bush, wheel spacer, Driven wheel bush, Spacer, Washer, idler Gear, Wheel Spacer, Washer, housing , Helical spring for long travel mechanism of 35T gantry crane of Telengiri Irrigation Project** ” and also date of opening of tender. The name and address of the tenderer should not be written on outer cover. Only the name and address of the purchaser should be written on the outer cover.
4. The offer should contain the following copies:
 - a) Valid GST Registration Certificate (self attested).
 - b) PAN Card (self attested).
 - c) Purchase orders, credentials, certificates etc. in support of supply of similar items of similar magnitude during any one financial year of last 5 financial years(i.e. from financial year 2021-22 to 2025-26)(self attested).
 - d) The original terms & conditions, price schedule duly signed by the tenderer, without which the offer will not be considered .
 - e) EMD of 1% as per clause- 2 above
5. The tenderer will quote their rates F.O.R. OCCL Store, Central Workshop, Rasulgarh, Bhubaneswar indicating separately the basic price per each inclusive of packing, forwarding, transportation, transit insurance and handling charges & GST, duties, levies etc. strictly in the detailed specifications and price schedule format in original. All columns and lines of the price schedule should be filled in properly without leaving anything blank. The details and rates of duties, taxes and levies etc. should be indicated clearly in the price schedule.
6. The tender document should be submitted a) through Speed Post along with the required self attested hard copies b) through email ID (smcwsoccltender@gmail.com) (different password protected for technical and financial Bid along with the required self attested scan copies within stipulated date and time . The undersigned will not be responsible for any kind of delay by the postal authorities or any technical issue of website.
7. The Tenderer should submit tender cost along with self attested photo copies of above documents. The Envelope-I / Enclosure (Technical) will contain complete tender document along with all above required documents, EMD and cost of tender documents. The Envelope -II / Enclosure (Financial) will contain only financial Bid, otherwise, the offer shall not be considered and OCCL will not be responsible for missing of any pages .
8. The Bid documents (technical bid & price bid) submitted through e-mail by the bidders must be password protected & the password is to be set by the Bidder himself.

**Signature of the Tenderer agency or
His/their Power of attorney holder
with designation & seal.**

**Senior Manager (Mech.)-I
OCC Ltd, Central Workshop,
Rasulgarh, Bhubaneswar-10.**

9. The Bid documents (technical bid & price bid) will be opened in presence of the interested bidders on the scheduled date and time as mentioned in the tender.
10. The password is to be revealed or intimated by the tenderer or Bidder at the time of opening of price Bid documents.
11. The Bids received through e-mail without password will be out-rightly rejected.
12. The tenderer who will participate through email (**smcwsoccltender@gmail.com**), must upload all the self attested technical Bid documents in one Enclosure (Technical) and the Price schedule in another Enclosure (Financial). The tenderer (participated through e-mail) will scan the relevant documents and upload the same along with password protection. Subject of the Email should be **"Tender for Supply of casting items in finished condition i.e., Driving wheel, wheel gear, Driven wheel, Idler Gear, Pinion, driving wheel bush, idler Gear bush, wheel spacer, Driven wheel bush, Spacer, Washer, idler Gear, Wheel Spacer, Washer, housing, Helical spring for long travel mechanism of 35T gantry crane of Telengiri Irrigation Project "**.
13. Original copy of tender, tender paper cost must submitted to the undersigned within 05(five) days of opening of tender, otherwise bid shall be rejected and the Bidder will be debarred for participation in any future tender.
14. The tenders will be received and opened in the office of the undersigned as per the information in the table of tender call notice in presence of the Tenderer or their authorized representatives, if they so desire.
15. If there will be a public holiday on the last date of sale of tender document and receipt & opening of the tenders as specified above, the tender document will be sold and tenders will be received & opened on the next working day at the same time and venue.
16. The tenderer should quote appropriate taxes with the offer.
17. The rates and amounts should be quoted both in figures and words in the price schedule. Any correction or overwriting in the specification and price schedule should be duly certified by the tenderer or his power of attorney holder. In case of any mismatch in figures and words, the rates in words will be considered. In case of any mismatch in rates and amount, the rate will be considered.
18. The materials should be supplied in finished / fully machined conditions by successful tenderer / supplier as per required dia, length and quantity and should strictly conform to relevant standards of Bureau of Indian Standard (BIS) as mentioned in detailed specification and price schedule.
19. The original test certificate of materials from a Govt./Govt. approved testing laboratory will be provided by the successful tenderer/ supplier along with supply of materials. The manufacturer's test certificate will have to be also furnished by the successful tenderer/ supplier. The purchaser is having the option to test the materials in any laboratory at the cost of the supplier and if the materials are not found in accordance with the specifications and grade in relevant Indian Standards, the materials will be rejected.
20. The materials will be guaranteed by the supplier against any defect for a period of 18 months from the date of supply or 12 months from the date of use, whichever is earlier. Guarantee certificate in this regard will accompany with supply of materials. If any defect is found in the materials within the guarantee period, the same will have to be replaced free of cost by the supplier.
21. The rate of materials should be quoted by the tenderer on unit basis only. The same should be supplied by the successful supplier as per required dia, length and quantity in numbers as mentioned in detail specification and Price Schedule.
22. Pre-delivery inspection (P.D.I) before despatch of the materials will be made at the manufacturer's works by the authorized representative of the purchaser / client / third party for which the manufacturer should intimate in writing for P.D.I. 10 days in advance regarding readiness for P.D.I.

**Signature of the tenderer or his/their
power of attorney holder
with designation & seal.**

**Senior Manager (Mech.)-I
OCC Ltd, Central Workshop,
Rasulgarh, Bhubaneswar-751010**

23. The tenderer will quote their rates F.O.R. OCCL Store, Central Workshop, Rasulgarh, Bhubaneswar-10 (Odisha) indicating separately the basic price, packing, forwarding, transportation, transit insurance, handling charges, taxes, duties, levies etc. strictly in the specifications and price schedule format in original. All columns and lines of the specification and price schedule should be filled in properly without leaving any thing blank. The details and rates of duties, taxes etc. should be indicated clearly in the specification and price schedule.
24. 90% payment will be made within 30 days of receipt, verification and acceptance of the complete materials along with bill, test certificate, guarantee certificate and other documents. Balance 10% will be released after 18 months of supply or 12 months from the date of commissioning whichever is earlier. However if a performance bank guarantee is received for 10% of the value of materials, the same will be released within 60 days from the date of receipt of materials.
25. The purchaser reserves the right to forfeit and encash the performance bank guarantee in full in case any casting is found defective and not replaced by the tenderer/supplier within a suitable time fixed by the corporation. Any repair to the casting shall be made only after approval of the purchaser. In this connection, the decision of the purchaser is final and binding on the tenderer/supplier.
26. Price escalation will not be allowed under any circumstances. The quoted rates will remain firm till execution of the work order.
27. The validity of the offer should be for a period of 120 (One hundred twenty) days from the date of opening of the tender.
28. The complete ordered quantity shall be supplied by the successful tenderer within 90 (Ninety) days from the date of issue of purchase order failing which the order is liable for cancellation without assigning any reason thereof by the purchaser. In case of cancellation of the order the EMD will be forfeited. In case of any delay in supply of material beyond the delivery schedule whatever may the reason, supplier shall be liable to pay L.D. @ 0.5% (Half percent) of the total order value per week of delay or part thereof subject to a maximum of 5% (Five percent) of the total order value.
29. After submission of tender and before placing order, the bidder may be asked by the undersigned to attend techno-commercial discussions and reply to queries within a specified period. If the bidder fail to do so, the tender submitted by the bidder is liable to be cancelled.
30. Conditional offers with deviations will not be accepted. Those, who do not agree to the terms and conditions regarding payments, delivery and others, need not quote.
31. The authority reserves the right to accept/reject any or all tenders without assigning any reason thereof. The required quantity of materials can be splitted among the two or more tenderers. In this connection, the decision of purchaser is final and binding on the tenderer.
32. The duplicate copy of the order shall be signed by the supplier on each page with his seal as acceptance of the order and shall be returned to the purchaser within 07 (Seven) days of receipt of this order failing which the order is liable for cancellation.
33. Tender through fax/telex/telegram/e-mail will not be accepted.
34. Any dispute arising out of this tender or order thereof is to be settled in proper court under the jurisdiction of Odisha High Court at Cuttack or courts under the jurisdiction of Odisha High Court at Bhubaneswar only.

**Signature of the tenderer or his/their
power of attorney holder
with designation & seal.**

**Senior Manager (Mech.)-I
OCC Ltd, Central Workshop,
Rasulgarh, Bhubaneswar-751010**

**ODISHA CONSTRUCTION CORPORATION LIMITED
(A GOVT. OF ODISHA UNDERTAKING)
CENTRAL WORKSHOP, RASULGARH,
BHUBANESWAR-751010 (ODISHA).**

DETAILED SPECIFICATION AND PRICE SCHEDULE FOR

“ Supply of casting items in finished condition i.e., Driving wheel, wheel gear, Driven wheel, Idler Gear, Pinion, driving wheel bush, idler Gear bush, wheel spacer, Driven wheel bush, Spacer, Washer, idler Gear, Wheel Spacer, Washer, housing , Helical spring for long travel mechanism of 35T gantry crane of Telengiri Irrigation Project ”

VIDE TCN No.OCC/CWS/PROC/TIP-08(V-II) /12 /2026-27 DATED.11.06.2026 DUE DATE OF OPENING ON DATED 20.06.2026

Sl. No.	Description of Item	Part No	Unit	Qty. Reqd. in unit	Rate per unit in Rs.					Total amount in Rs. for full materials	
					Basic Price per unit	Packing, forwarding, transportation, transit insurance, handling charges, incidental charges etc.	GST as applicable	Total in figures	Total in words	In figure	In words
1	Driving wheel of material - Cast Steel GR-4 of IS:2644 - 1994 (As per drawing in Annexure – I)	16-1	Nos.	4							
2	Wheel gear of materials- Cast Steel GR-3 of IS:2644 - 1994. (As per drawing in Annexure – II)	16-2	Nos.	4							
3	Driven wheel of material - Cast Steel GR-4 of IS:2644 - 1994. (As per drawing in Annexure – III)	16-3	Nos.	4							
4	Idler gear of material - Cast Steel GR-3 of IS:2644 - 1994. (As per drawing in Annexure – IV)	16-4	Nos.	2							
5	Pinion of Material - Cast Steel GR-4 of IS:2644 - 1994. (As per drawing in Annexure – V)	16-5	Nos.	2							
6	Driving wheel bush of material - AB-1 of IS:305 - 1981. (As per drawing in Annexure –VI)	16-6	Nos.	4							
7	Idler gear bush of material - HTB-1 of IS:304 - 1981. (As per drawing in Annexure – VII)	16-7	Nos.	8							
8	Wheel spacer of material - Cast Steel GR.200-400N of IS:1030 - 1989 (As per drawing in Annexure – VIII)	16-8	Nos.	12							
9	Driven wheel bush of material - AB-1 of IS:305-1981 (As per drawing in Annexure – IX)	16-9	Nos.	4							

Signature of the tenderer or his/their
power of attorney holder
with designation & seal.

Senior Manager (Mech.)-I
OCC Ltd, Central Workshop,
Rasulgarh, Bhubaneswar-751010

Sl. No.	Description of Item	Part No	Unit	Qty. Reqd. in unit	Rate per unit in Rs.					Total amount in Rs. for full materials	
					Basic Price per unit	Packing, forwarding, transportation, transit insurance, handling charges, incidental charges etc.	GST as applicable	Total in figures	Total in words	In figure	In words
10	Spacer (For idler gear) of materials - Cast Steel GR.200-400N of IS:1030 - 1989 (As per drawing in Annexure – X)	16-10	Nos.	4							
11	Washer (For wheel) of material- Brass of IS : 410-1977 (As per drawing in Annexure – XI)	16-14	Nos.	16							
12	Idler gear(Between wheel gear & pinion) of material - Cast Steel GR-3 of IS:2644 - 1994 (As per drawing in Annexure – XII)	16-26	Nos.	2							
13	Wheel spacer (At wheel gear side on driving wheel shaft) of material - Cast Steel GR. 200-400N of IS:1030 - 1989 (As per drawing in Annexure – XIII)	16-27	Nos.	4							
14	Washer (For idler pin) of materials - Brass of IS:410-1977 (As per drawing in Annexure – XIV)	16-28	Nos.	8							
15	Housing of material - Cast Steel Gr. 280 – 520w of IS : 1030-1989 (As per drawing in Annexure – XV)	17-1	Nos.	4							
16	Guide of material - Cast steel Gr. 280 – 520W of IS : 1030-1998 (As per drawing in Annexure –XVI)	17-3	Nos.	4							
17	Helical compression spring (ends closed and ground) of material- 55 Si7 of IS : 3195-1982 (As per drawing in Annexure –XVII)	17-4	Nos.	4							

Signature of the tenderer or his/their power of attorney holder with designation & seal.

**Senior Manager (Mech.)-I
OCC Ltd, Central Workshop,
Rasulgarh, Bhubaneswar-751010**

Annexure-I

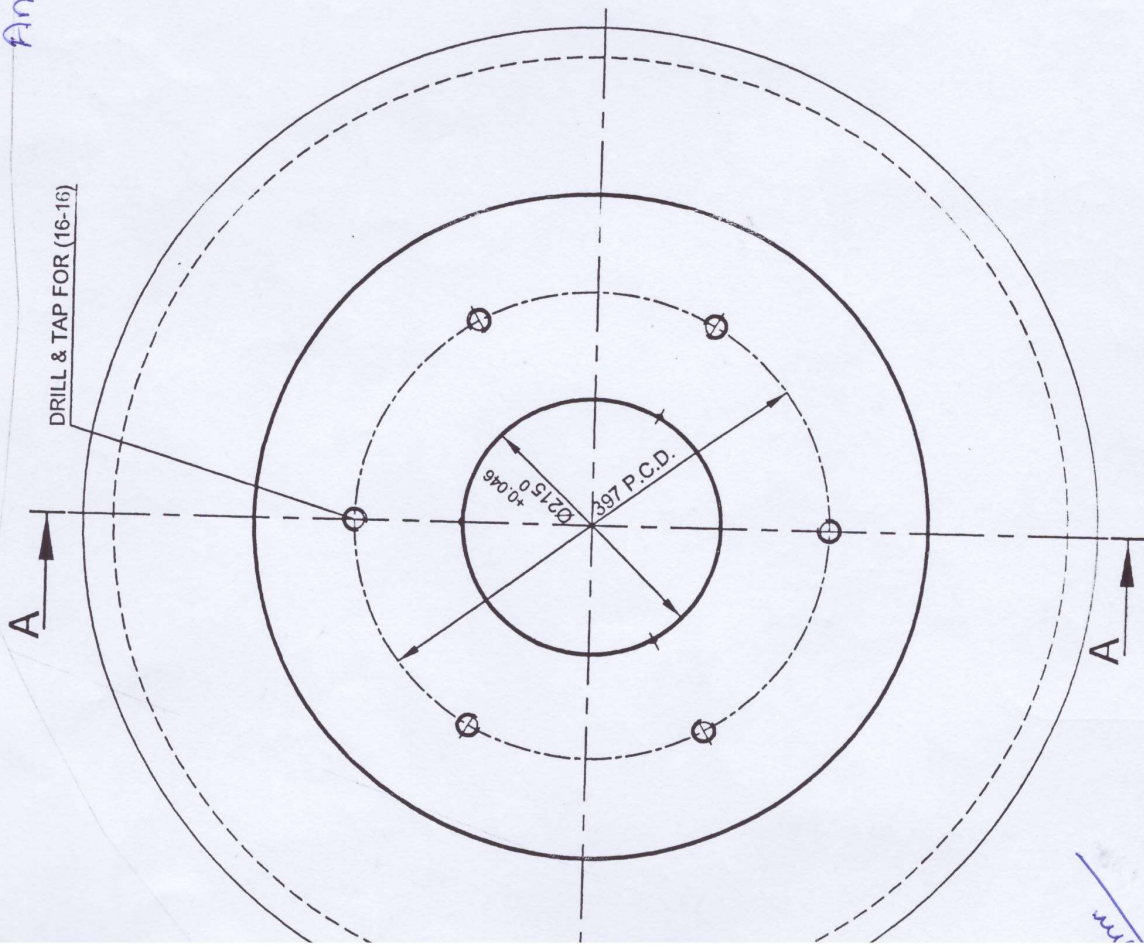

END VIEW

DRIVING WHEEL (16-1)

MATERIAL - CAST STEEL GR.-4 OF IS:2644 - 1994
TOTAL NOS. REQD. - 4

Manager (Mech)
C.C. Ltd.
ral Workshop
rasulgarh

Note - (16-16) - Max. Speed 2000 RPM IS: 1364 (Part-2)
ISO: 4017 M20X 160-8.8 with washer.

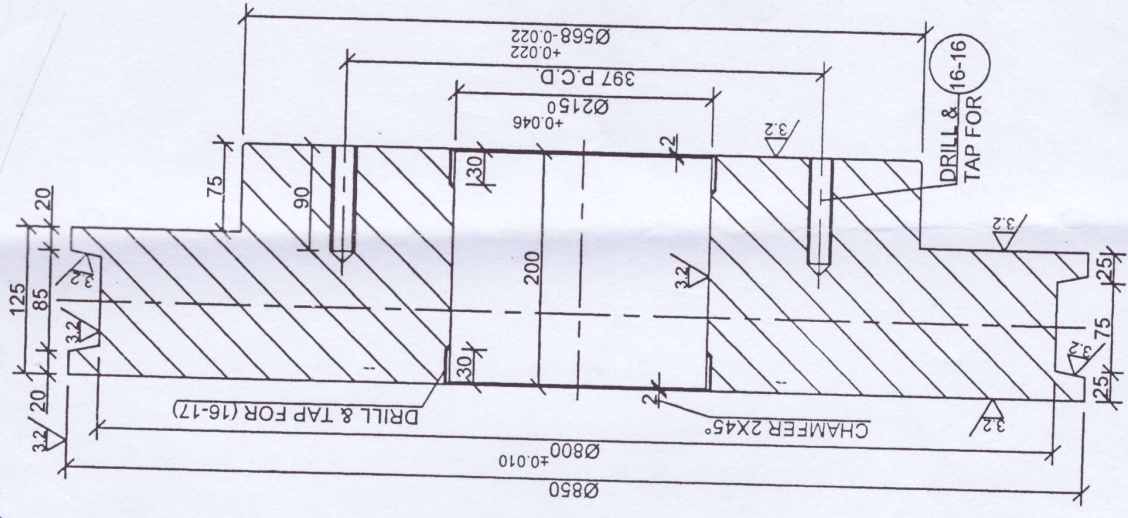

SECTION - AA

35 T GANTRY CRANE OF
TELENGIRI IRR. PROJECT.
O.C.C.L.

Note - 16-17 -
Grub screw CM8 X 30
IS: 6094-10.9.

Annexure - II

Senior Manager (Mech)
O.C.C. Ltd.
Central Workshop
Rasulgarh

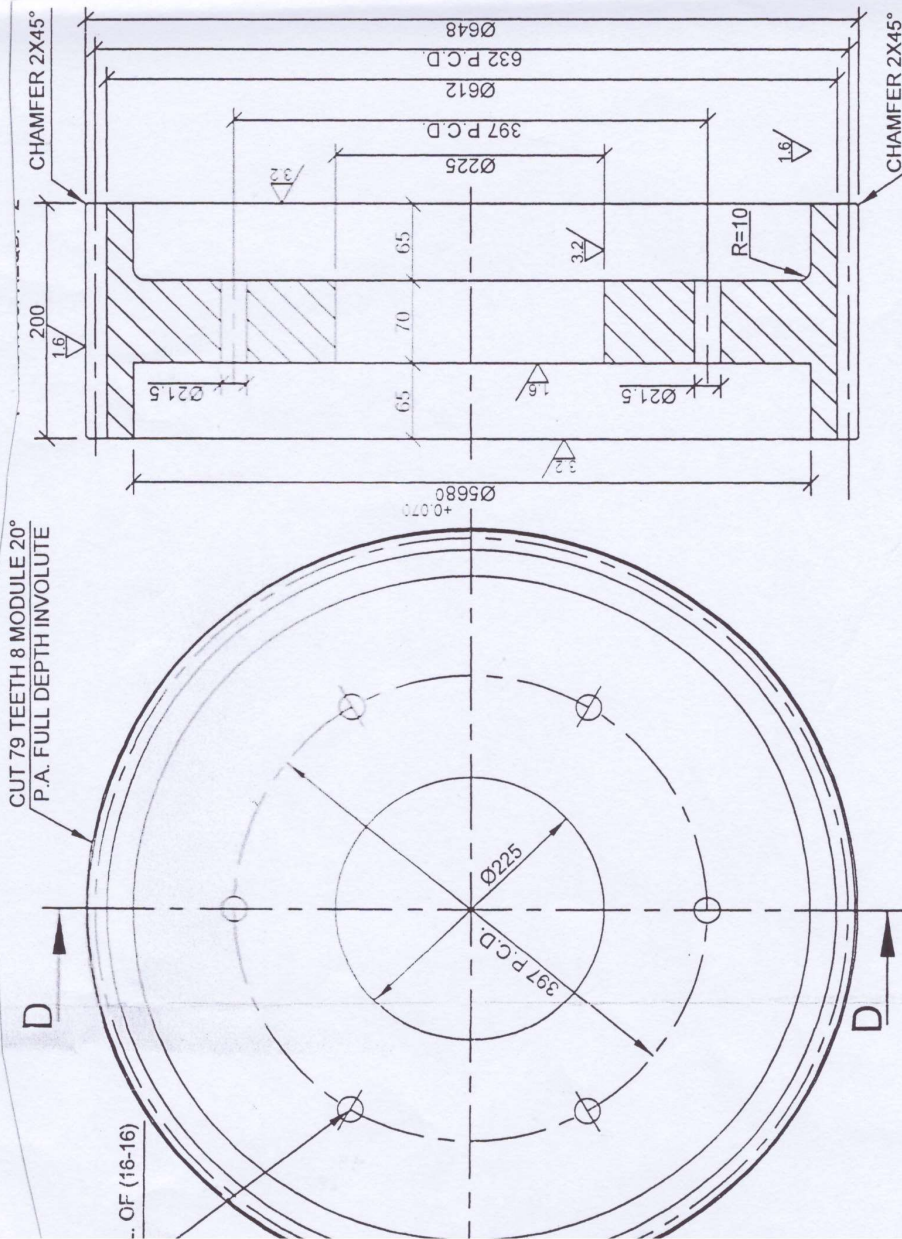

SECTION - DD

END VIEW

WHEEL GEAR 16-2

MATERIAL - CAST STEEL GR.-3 OF IS:2644 - 1994
TOTAL NOS. REQD. - 4

Note - (16-16) - Hex. head screw IS:1364
CR-2 / ISO:4017 M20 X160 - 8.8 with
washer.

35T GANTRY CRANE OF TELANGANA
IRR. PROJECT.
OCCU.

Avenue-III

[Signature]
Senior Manager (Mech)
O.C.C. Ltd.
Central Workshop
Rasulgarh

35T GANTRY CRANE
OF TELENGIRI IRR.
PROJECT.
OCCL.

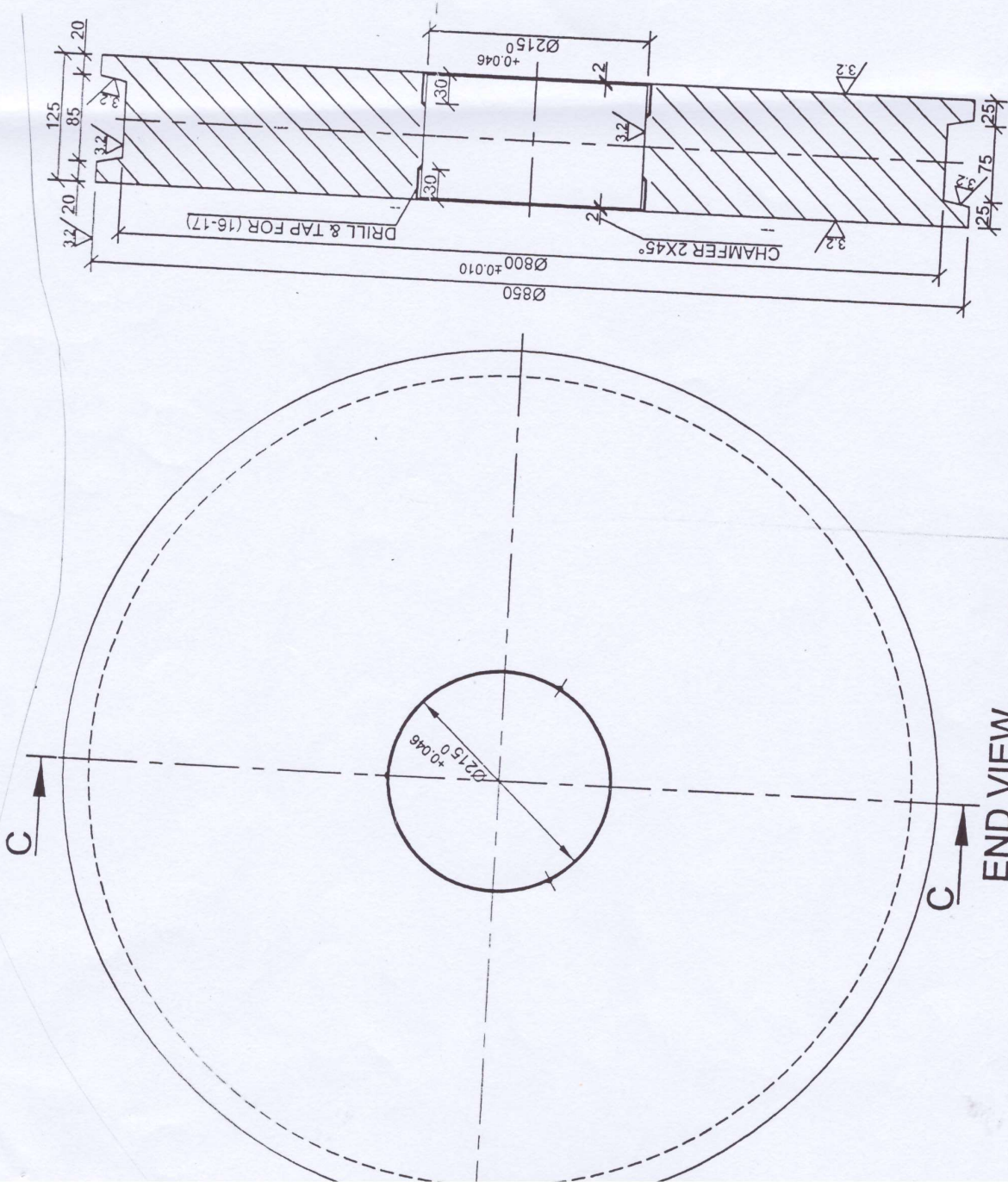

DRIVEN WHEEL ¹⁶⁻³ **SECTION - CC**

MATERIAL - CAST STEEL GR-4 OF IS:2644 - 1994

TOTAL NOS. REQD. = 4 (FOUR) NOS.
Note: (16-17) - Grub screw CM 8 X 30 IS: 6094 - 10.9

Annexure - IV

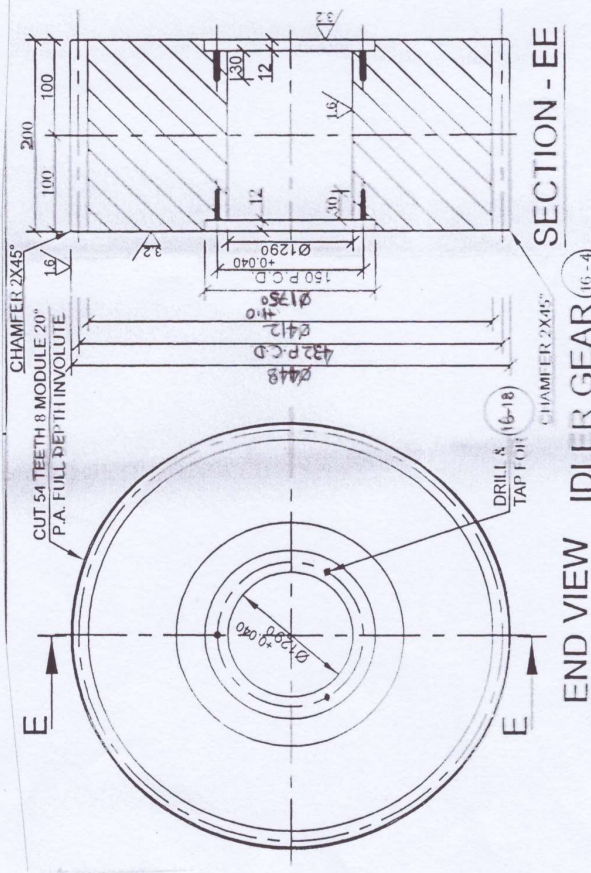

END VIEW IDLER GEAR (16-4)
 (BETWEEN WHEEL GEARS)
 MATERIAL - CAST STEEL GR. 3 OF IS:2644 - 1994
 TOTAL NOS. REQD - 2

[Signature]
 Senior Manager (Mech)
 O.C.C. Ltd.
 Central Workshop
 Rasulgarrh

Note:- (16-18) - Slotted countersunk head screw M6 X 40 IS: 1365 - 4.8

3ST GANTRY CRANE OF
 TELENGIRI IRB. PROJECT,
 OCCL.

Annexure-9

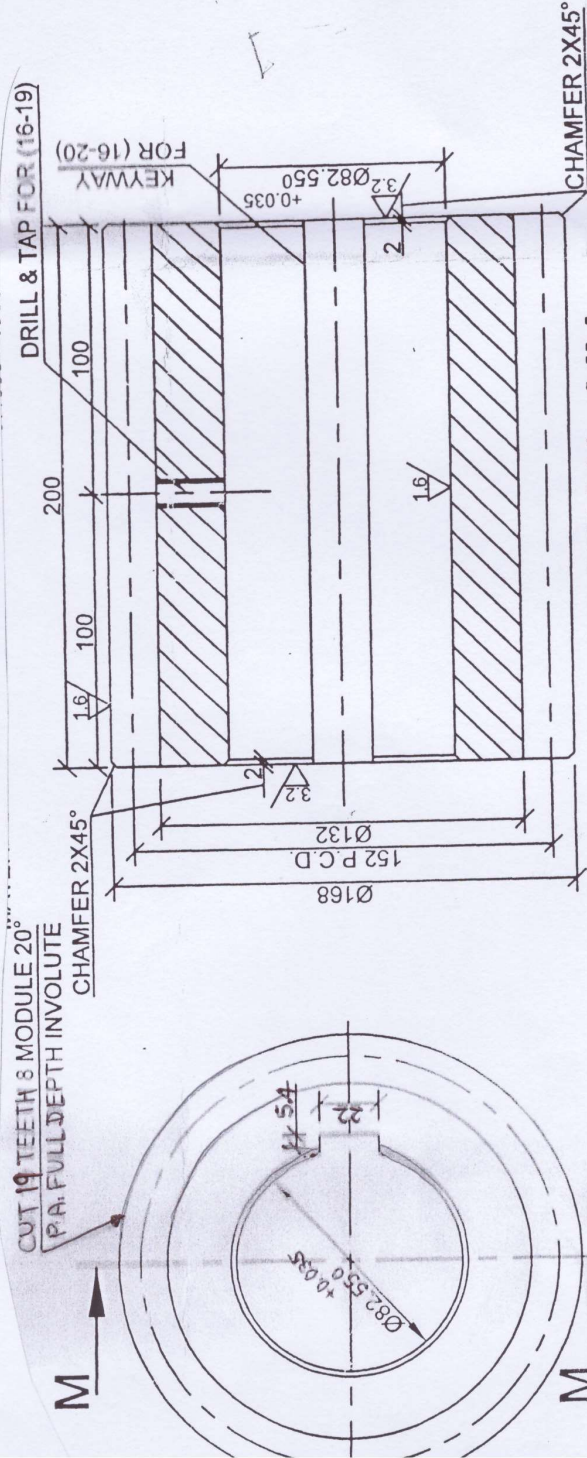

PINION (16-5)

MATERIAL - CAST STEEL GR.-4 OF IS:2644 - 1994
TOTAL NOS. REQD. - 2

Note:- (16-19) - Grub screw M10X20 IS: 6094 - 10.9
(16-20) - Parallel key A22X14X200 LONG, IS: 2048

Senior Manager (Mech)
O.C.C. Ltd.
Central Workshop
Rasulgarh

35T GANTRY CRANE OF
TELENGIRI IRR. PROJECT,
OCC.

Annexure-VI

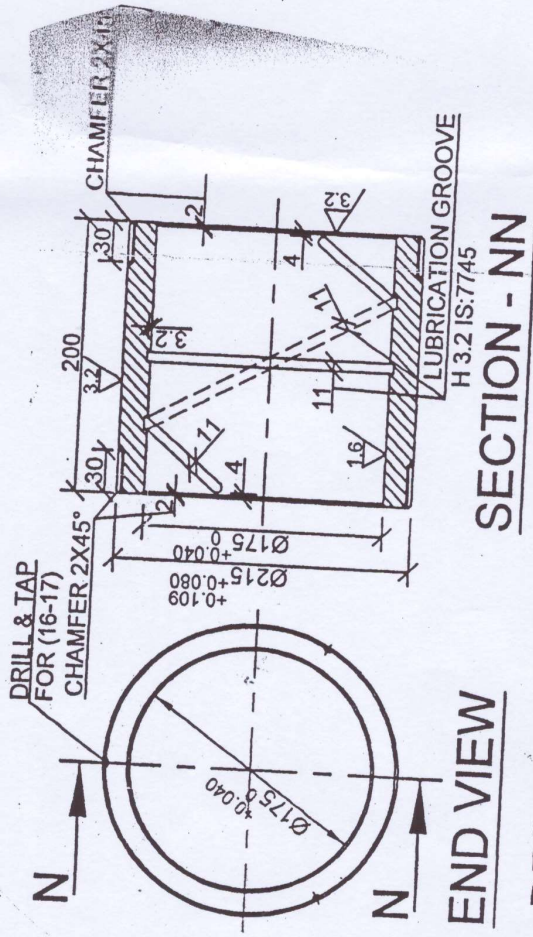

DRIVING WHEEL BUSH (16-6)

MATERIAL - AB-1 OF IS: 305 - 1981

TOTAL QTY. REQD. = 04 (FOUR) NOS.

Note: - (16-17) - Groove & screw CM 8 X 30 IS: 6094 - 109

Senior Manager (Mech)
O.C.C. Ltd.
Central Workshop
Rasulgarh

35T GANTRY CRANE OF
TELENGIRI IRR. PROJECT.
OCCL.

Annexure - VII

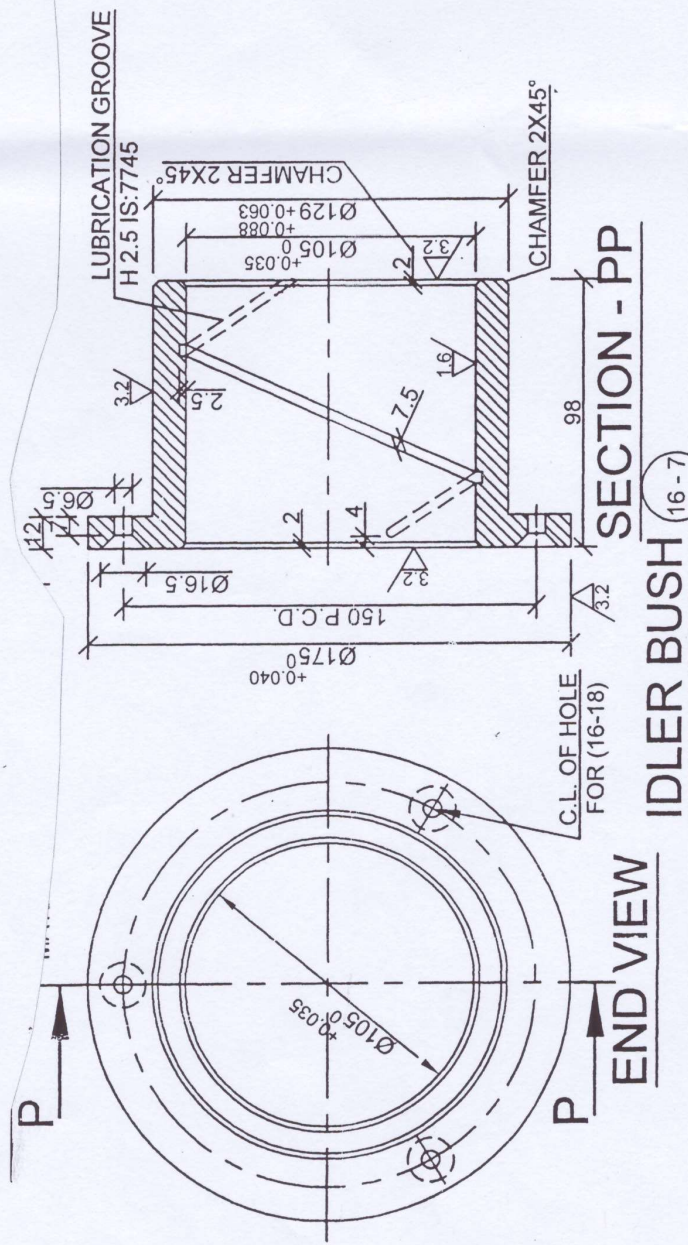

16-7
IDLER BUSH

MATERIAL - HTB-1 OF IS:304 - 1981

TOTAL QTY. = 08 (EIGHT) NOS.

Note:- (16-18) - Slotted round sunk head screw

M6 X 40 IS: 1365 - H.8

Senior Manager (Mech)
O.C.C. Ltd.
Central Workshop
Rasulgarh

35 T GANTRY CRANE OF
TELANGIRI IRR. PROJECT.
OCCL.

Annexure - VIII

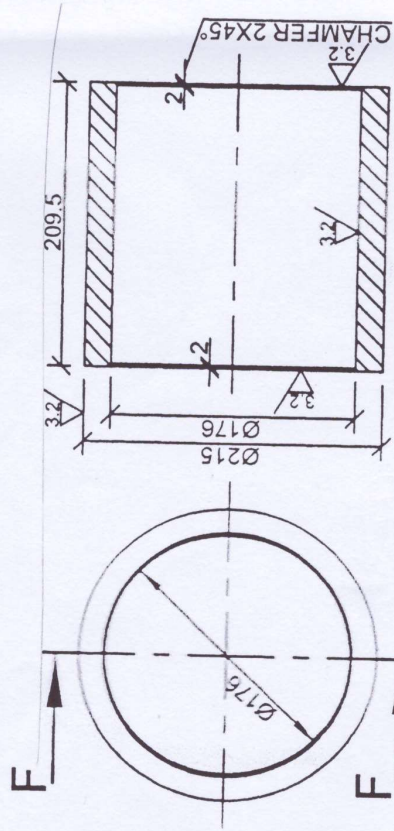

SECTION - FF

WHEEL SPACER¹⁶⁻⁸

MATERIAL - CAST STEEL GR. 200-400N OF IS:1030 - 1989

Senior Manager (Mech)
O.C.C. Ltd.
Central Workshop
Rasulgarh

TOTAL QTY. REQD. = 12 (TWELVE) NOS.

35T GANTRY CRANE OF
TELENGIRI IRR. PROJECT.
OCC.

Annexure - IX

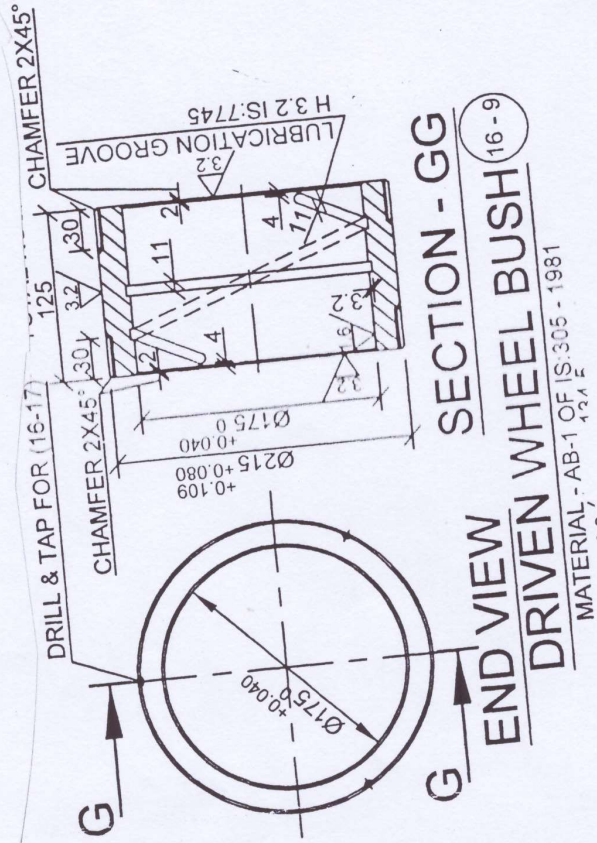



Senior Manager (Mech)
O.C.C. Ltd.
Central Workshop
Rasulgarh

TOTAL QTY. REQD. = 04 (FOUR) NOS.

Note: - (16-17) - Grub screw CM 8X30 IS: 6094 - 10.9.

3ST GANTRY CRANE OF
TELENGURI IRR. PROJECT.
OCCL.

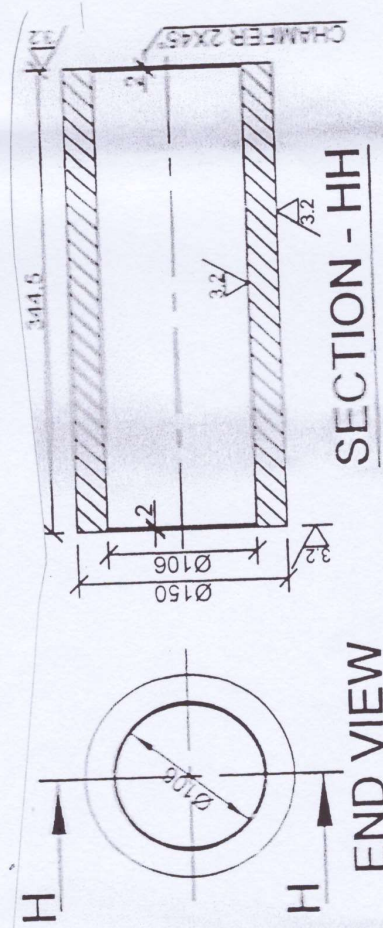
Annexure - A



SPACER (16-11)

(FOR IDLER GEAR)
MATERIAL - CAST STEEL GR. 200-400N OF IS:1030 - 1989

TOTAL QTY. REQD. = 04 (FOUR) NOS.

Senior Manager (Mech)
O.C.C. Ltd.
Central Workshop
Rasulgarh

35 T GANTRY CRANE OF
TELENGIRI IRR. PROJECT,
O.C.C.

Annexure - XI

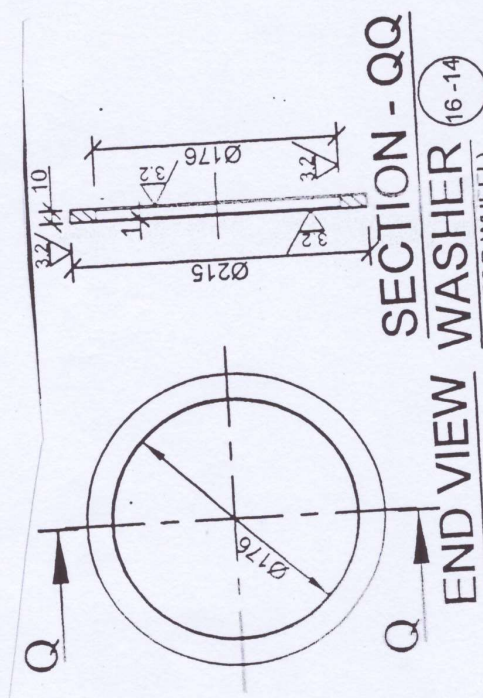

(FOR WHEEL)
MATERIAL - BRASS OF IS:410 - 1977

TOTAL QTY. REQD. = 16 (SIXTEEN) NOS.

[Signature]
Senior Manager (Mech)
O.C.C. Ltd.
Central Workshop
Rasulgarh

3ST GANTRY CRANE OF
TELENGIRI IRR. PROJECT.
OCCL.

35T GANTRY CRANE
 OF TELEGIRI
 IRR. PROJECT.
 O.C.C.L.

[Signature]
 Senior Manager (Mech)
 O.C.C. Ltd.
 Central Workshop
 Raipur

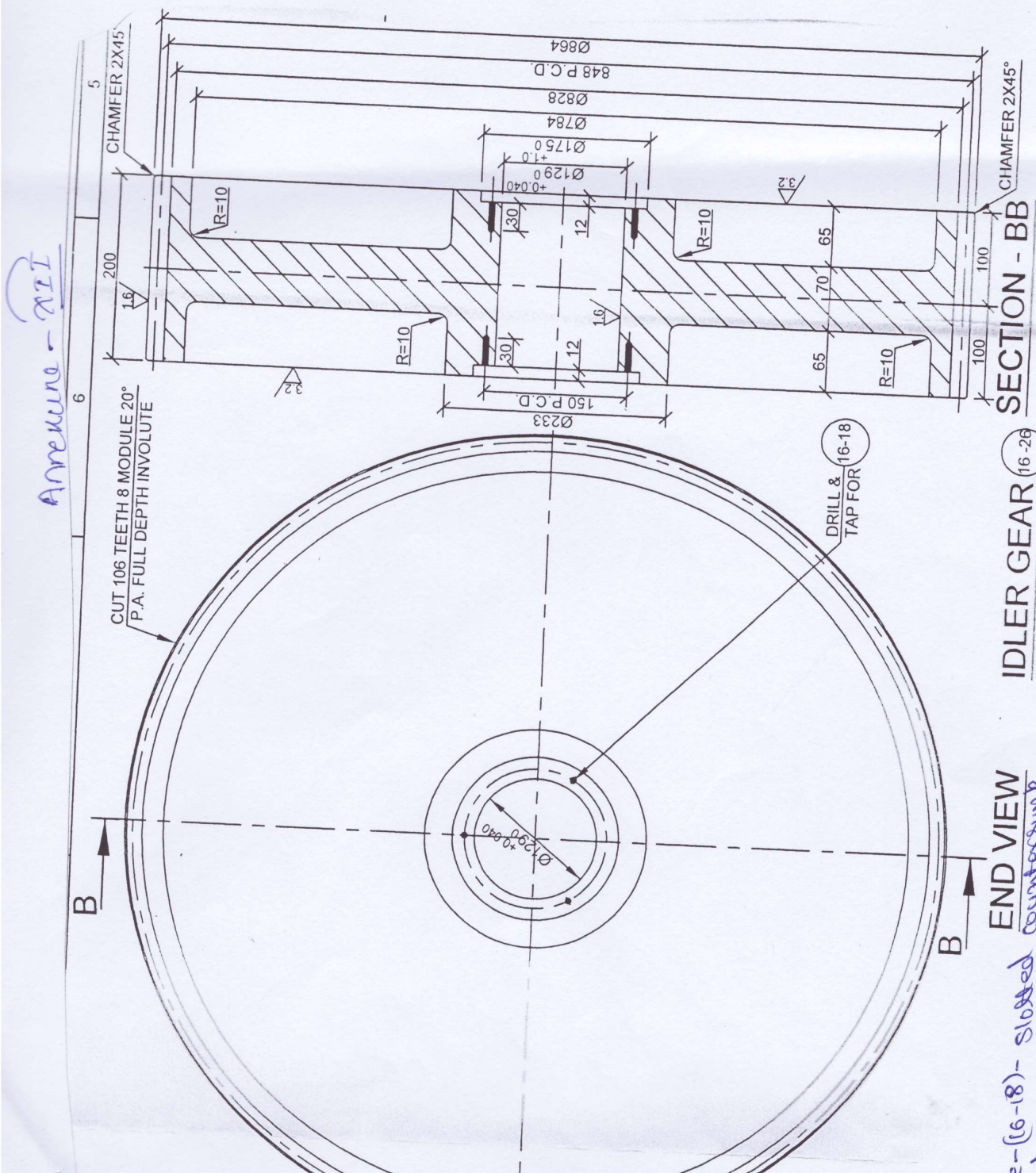

SECTION - BB

IDLER GEAR (16-26)
 (BETWEEN WHEEL GEAR & PINION)

MATERIAL - CAST STEEL GR. - 3 OF IS: 2644-1994

TOTAL NOS. REQD. = 02 (TWO) NOS.

END VIEW

2 - (16-18) - SLOTTED
 counter screw
 of screw M6 X 40 IS: 1365-4.8

Annexure - VII

Annexure - XIII

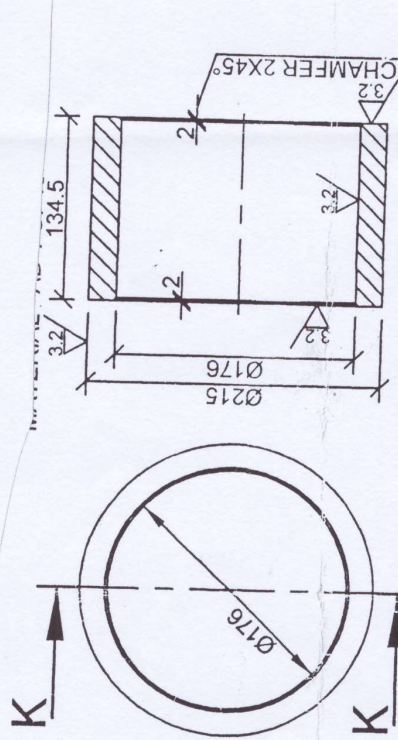

SECTION - KK
WHEEL SPACER¹⁶⁻²⁷
(AT WHEEL GEAR SIDE ON DRIVING WHEEL SHAFT)
MATERIAL - CAST STEEL GR. 200-400N OF IS:1030 - 1989

TOTAL QTY = 04 (FOUR) NOS.

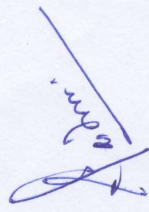
Senior Manager (Mech)
O.C.C. Ltd.
Central Workshop
Rasulgarh

35T GANTRY CRANE OF
TELENGIRI FRR. PROJECT.
O.C.C.

Annexure - 21A

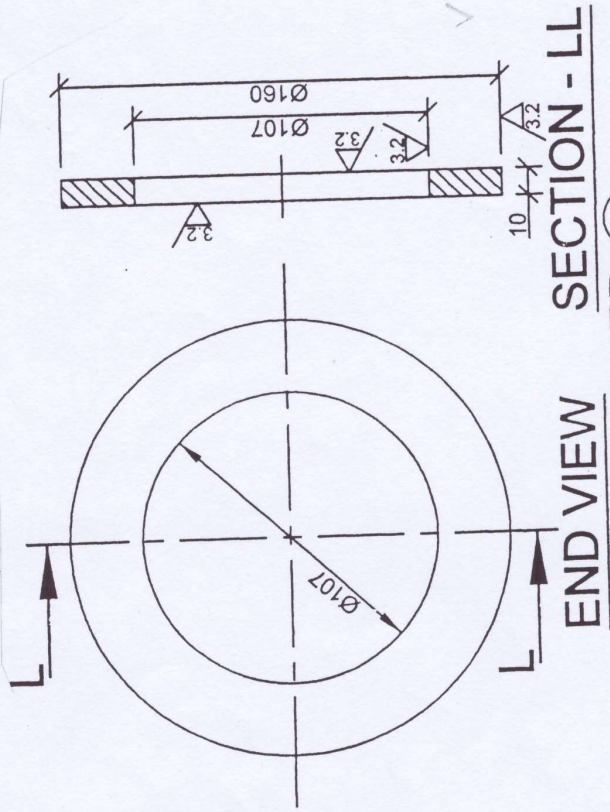

WASHER 16-28

(FOR IDLER PIN)
MATERIAL - BRASS OF IS:410 - 1977

TOTAL QTY. REQD. - 08 (EIGHT) NOS.

Senior Manager (Mech)
O.C.C. Ltd.
Central Workshop
Rasulgarh

35T GANTRY CRANE OF TELENGIRI
IRR. PROJECT.
OCCU.

Annealed - 2N

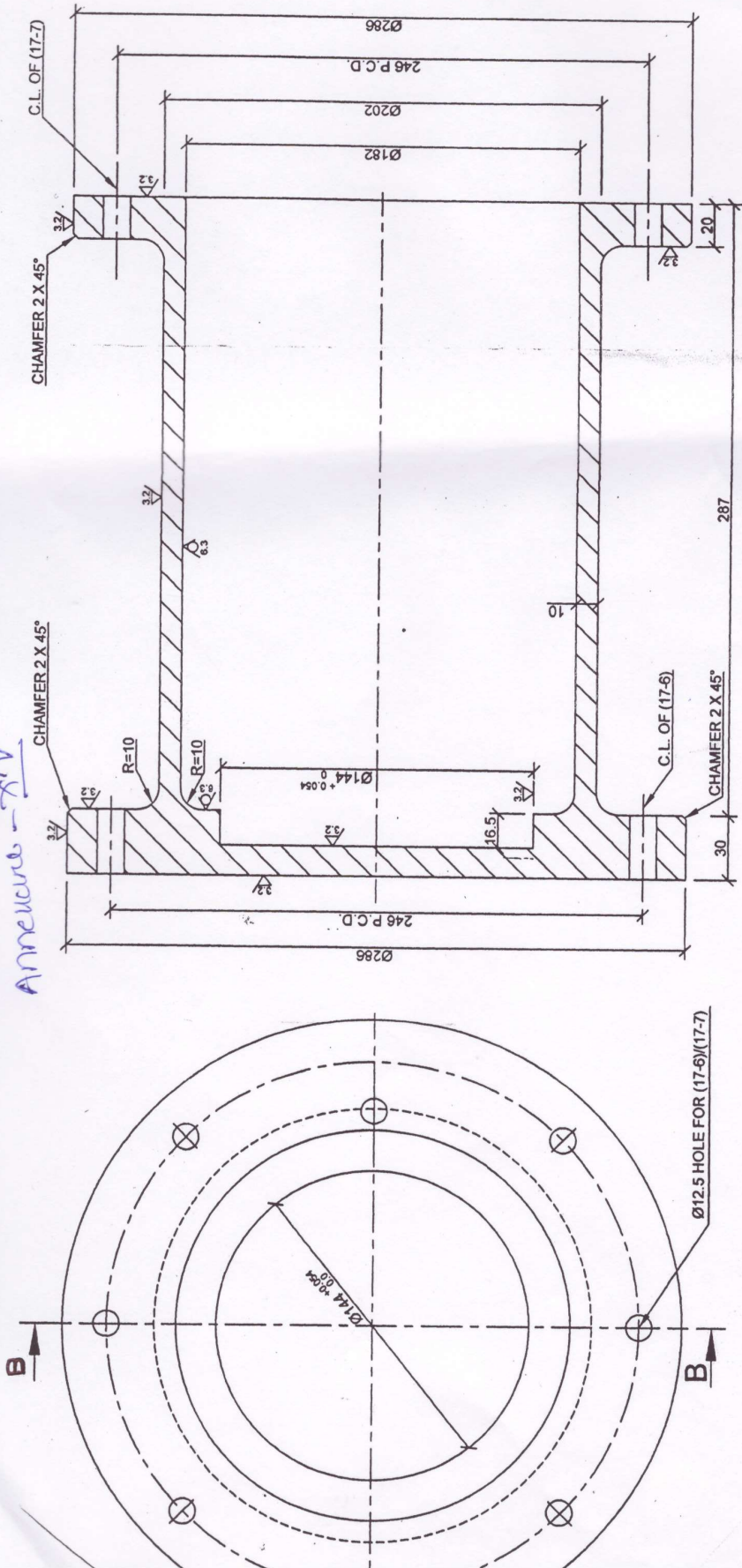

END VIEW

HOUSING (17-1)

MATERIAL:- CAST STEEL GR. 280-520W OF IS:1030 - 1998

SECTION - BB

TOTAL QTY. = 04 (FOUR) NOS.

3ST GANTRY CRANE TO OPERATE
STOPLOGS OF SPILLWAY.
OCCL.

Annexure - XVI

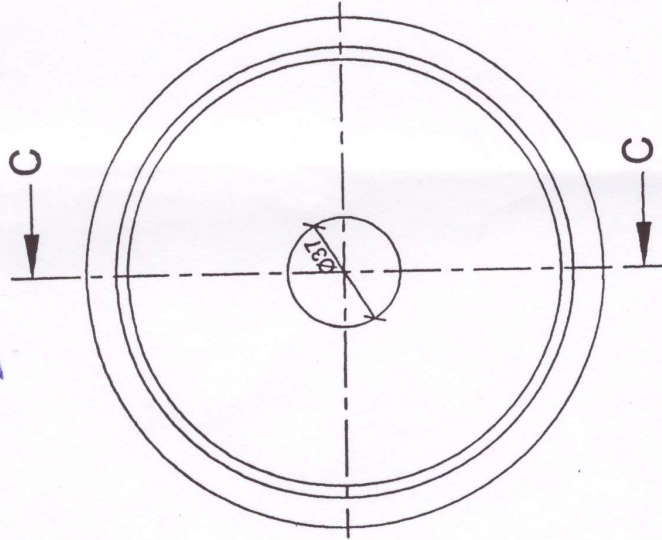

END VIEW

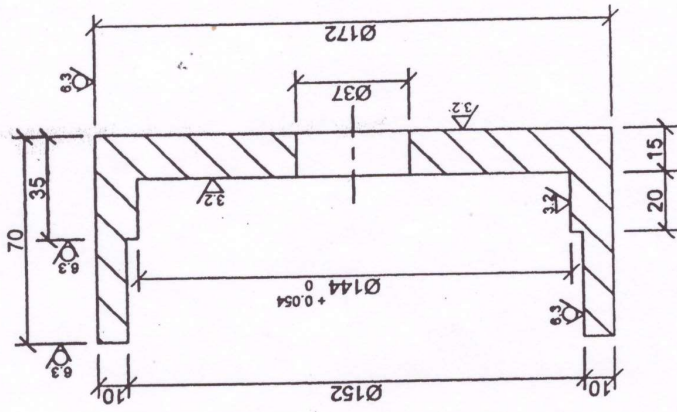

SECTION - CC

GUIDE 17-3

MATERIAL - CAST STEEL GR. 280-520W OF IS:1030 - 1998

TOTAL QTY. = 04 (FOUR) NOS.

3ST GANTRY CRANE TO OPERATE
STOPLOGS OF SPILLWAY.
OCCL.

Annexure - (XVII)

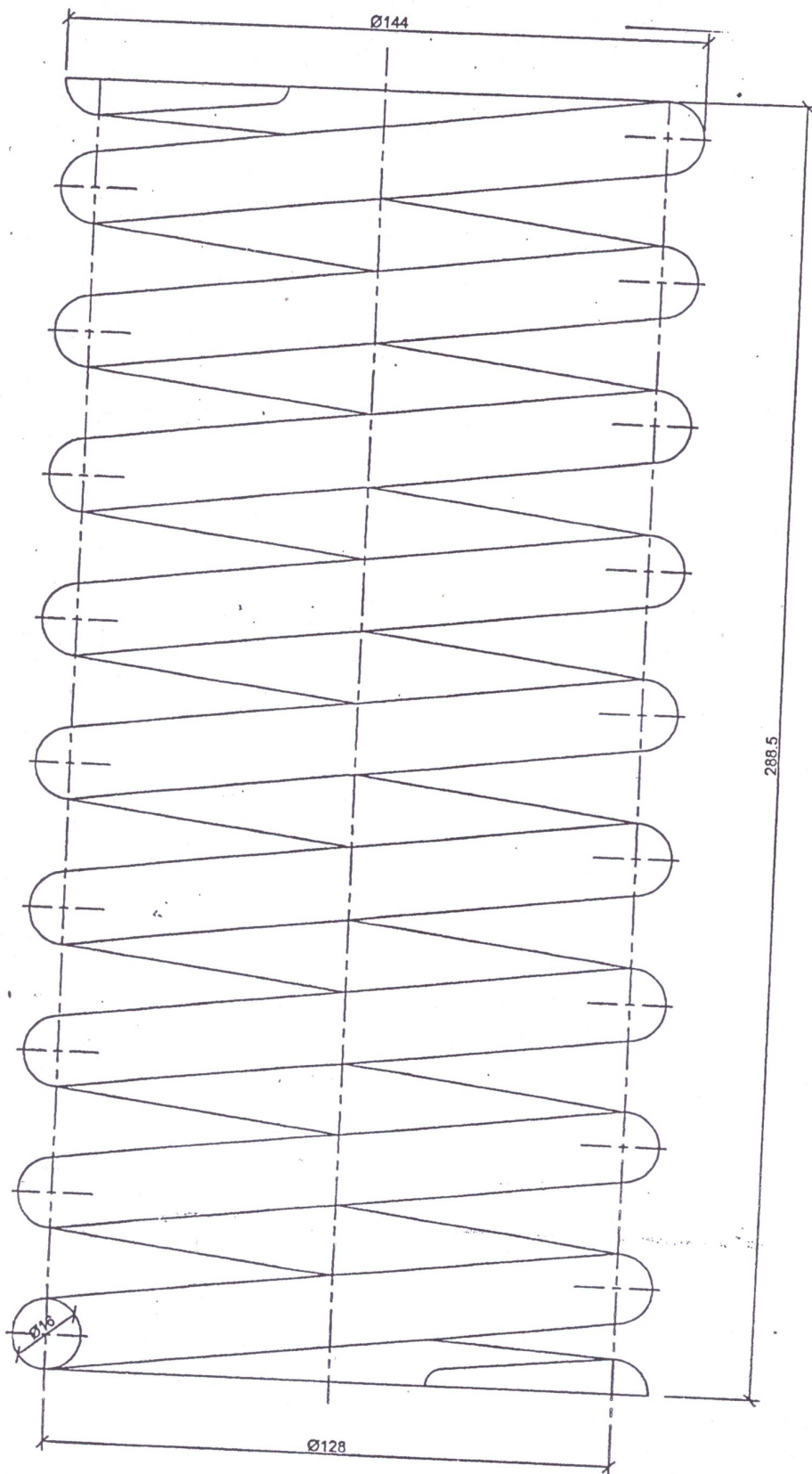

HELICAL COMPRESSION SPRING (17-4)

TOTAL QTY. = 04 (FOUR) NOS.

35T GANTRY CRANE TO O
STOPLOGS OF SPILLWAY.
OCCL.