

ODISHA CONSTRUCTION CORPORATION LIMITED
(A GOVT. OF ODISHA UNDERTAKING)
CENTRAL WORKSHOP, RASULGARH,
BHUBANESWAR-751010 (ODISHA)

* * * * *

TENDER DOCUMENT FOR

“ Supply of Rope drum, drum gear, first pinion, second gear in casting condition, bush for pulley, bronze bush and pulley in finished condition respectively for 25T gantry crane of Lower Suktel Irrigation Project ”

The tender document comprises of the following:

1)	Tender call notice No. OCC/CWS/PROC/ LSIP-21 / 06 /2026-27 dated.02.05.2026(Including cover page)	03 (Three) sheets
2)	Terms and conditions	03 (Three) sheets
3)	Drawings	08 (Eight) sheets
4)	Price schedule	01 (One) sheets
----- Total :		15 (Fifteen) sheets -----

**Signature of the tenderer or his/their
power of attorney holder
with designation & seal.**

**Senior Manager (Mech.)-I
OCC Ltd, Central Workshop,
Rasulgarh, Bhubaneswar-751010**

ODISHA CONSTRUCTION CORPORATION LIMITED
(A GOVT. OF ODISHA UNDERTAKING)
CENTRAL WORKSHOP, RASULGARH,
BHUBANESWAR-751010 (ODISHA)

TENDER CALL NOTICE No. OCC/CWS/PROC/ LSIP-21 / 06 /2026-27 dated 02.05.2026

Sealed Tender (through Speed Post) / (through Password protected email) in conformity with the terms & conditions are invited from the reputed manufacturers / Trader / Supplier for “**Supply of Rope drum, drum gear, first pinion, second gear in casting condition, bush for pulley, bronze bush and pulley in finished condition respectively for 25T gantry crane of Lower Suktel Irrigation Project** ” as per details below:

Cost of Tender Document (Non-refundable)	Sale of Tender Document		Earnest money deposit (EMD) required	Receipt of Tender	Opening of Technical & Price Bid of Tender
	From	To			
Rs. 4000/- + GST @ 18% (Rs.4720/- by hand, Rs.4820/- by Speed Post)	05.05.2026 (10.30AM onwards)	15.05.2026 (up to 5.30 PM)	1(One)% of the total quoted value including GST	On 15.05.2026 (upto 3.30 PM)	On 15.05.2026 (4.00 PM onwards)

- Tender document can be purchased by the interested reputed manufacturers / Trader / Supplier by hand from the office of the undersigned on payment of cost of tender document i.e. **Rs.4000/- + GST @ 18%** amounting to **Rs.4720/-** in cash or in shape of A/c. payee demand draft on any Nationalised Bank / Scheduled Bank payable at Bhubaneswar (Non-refundable) drawn in favour of “**Odisha Construction Corporation Limited - Project Account**” and on production of attested copies of the following documents and verification thereof by the undersigned.
 - Valid GST Registration Certificate.
 - PAN Card.
- The tender document can also be obtained by the interested reputed manufacturers by Speed Post on sending the cost of tender document i.e. **Rs.4000/- + GST @ 18%** and postage charges of **Rs.100/-** amounting to **Rs.4820/-** in shape of A/c. payee demand draft drawn on any Nationalised Bank / Scheduled Bank payable at Bhubaneswar (Non-refundable) drawn in favour of “**Odisha Construction Corporation Limited - Project Account**” and on production of attested copies of the following documents and verification thereof by the undersigned.
- The tender document can also be downloaded from our Website www.odishaconstruction.com to submit the tender .
- The tender document should be submitted only through Speed Post along with the following self attested hard copies / Email along with the following self attested scan copies mail ID (smcwsoccltender@gmail.com) within stipulated date and time . The undersigned will not be responsible for any kind of delay by the postal authorities or any technical issue of website.
 - Valid GST Registration Certificate.
 - PAN Card.
 - Tenderer should submit valid manufacturer certificate / Trader license
 - The Bidder has to submit copies of purchase orders, credentials, certificates etc. in support of supply of similar items of similar magnitude(in total) in last 5 financial years (i.e. from financial year 2020-21 to 2024-25 including current financial year 2025-26).
- Bidders are requested to visit OCCL website regularly for addendum and corrigendum since any changes will not be published in news paper.

However, the cost of tender document i.e **Rs.4000/-** plus GST @ 18% amounting to **Rs.4720/-** in shape of A/c payee demand draft as stated above in favour of “**Odisha Construction Corporation Limited**” - **Project Account** on any Nationalised Bank/ Scheduled Bank payable at Bhubaneswar (Non-refundable) along with attested photo copies of all above documents should be submitted while submitting the tender in Envelope-I. Otherwise, the offer shall not be considered and OCCL will not be responsible for missing of any page while downloading. If there will be a public holiday on the last date of sale of tender document and receipt & opening of the tender as specified above, the tender document will be sold and tender will be received & opened on the next working day at the same time and venue.

**Signature of the tenderer or his/their
power of attorney holder
with designation & seal.**

**Senior Manager (Mech.)-I
OCC Ltd, Central Workshop,
Rasulgarh, Bhubaneswar-751010**

The SSI/NSIC/MSME units participating in tender are not entitled for exemption from payment of EMD/ Security Deposits/ Tender Paper costs as communicated vide DOWR Letter No. IIM-24/2018-14318/WR dated 24.05.2018 & Head Office, OCCL Letter No.5502/OCC/ CW-02/09(Vol-V)(WE) dated 30.05.2018.

The tenders will be opened in the presence of the tenderers or their authorised representatives. Tender through Fax/Telex/telegram will not be accepted

The undersigned reserves the right to accept or reject any or all tenders without assigning any reason thereof.

**Signature of the tenderer or his/their
power of attorney holder
with designation & seal.**

**Senior Manager (Mech.)-I
OCC Ltd, Central Workshop,
Rasulgarh, Bhubaneswar-751010**

ODISHA CONSTRUCTION CORPORATION LIMITED
(A GOVT. OF ODISHA UNDERTAKING)
CENTRAL WORKSHOP, RASULGARH,
BHUBANESWAR-751010 (ODISHA)

TERMS AND CONDITIONS OF TENDER FOR

“ Supply of Rope drum, drum gear, first pinion, second gear in casting condition, bush for pulley, bronze bush and pulley in finished condition respectively for 25T gantry crane of Lower Suktel Irrigation Project ”

1. Reputed manufacturers / Trader / Supplier having supplied similar item of similar magnitude earlier and satisfactorily accepted by the clients will be eligible to participate in the tender. The copies of purchase orders, credentials, certificates etc. in support of similar supply and satisfactory performance thereof shall be furnished along with the tender.
2. The tenderer should submit Earnest Money Deposit (EMD) @ 1(One)% of the total quoted value along with the tender in shape of A/C payee Demand Draft drawn in favour of “Odisha Construction Corporation Limited” - Project Account on any Nationalised Bank / Scheduled bank payable at Bhubaneswar. The tenders received without EMD will be out rightly rejected. EMD of the unsuccessful tenderers will be released only after finalization of the tender.
3. For submission of tender through Speed Post, the outer cover should be sealed and subscribe in bold letters as “ **Supply of Rope drum, drum gear, first pinion, second gear in casting condition, bush for pulley, bronze bush and pulley in finished condition respectively for 25T gantry crane of Lower Suktel Irrigation Project** ” and also date of opening of tender. The name and address of the tenderer should not be written on outer cover. Only the name and address of the purchaser should be written on the outer cover.
4. The offer should contain the following copies:
 - a) Valid GST Registration Certificate (self attested).
 - b) PAN Card (self attested).
 - c) Purchase orders, credentials, certificates etc. in support of supply of similar items of similar magnitude during any one financial year of last 5 financial years(i.e. from financial year 2021-22 to 2025-26)(self attested).
 - d) The original terms & conditions, price schedule duly signed by the tenderer, without which the offer will not be considered .
 - e) EMD of 1% as per clause- 2 above
5. The tenderer will quote their rates F.O.R. OCCL Store, Central Workshop, Rasulgarh, Bhubaneswar indicating separately the basic price per each inclusive of packing, forwarding, transportation, transit insurance and handling charges & GST, duties, levies etc. strictly in the detailed specifications and price schedule format in original. All columns and lines of the price schedule should be filled in properly without leaving anything blank. The details and rates of duties, taxes and levies etc. should be indicated clearly in the price schedule.
6. The tender document should be submitted a) through Speed Post along with the required self attested hard copies b) through email ID (smcwsoccltender@gmail.com) (different password protected for technical and financial Bid along with the required self attested scan copies within stipulated date and time . The undersigned will not be responsible for any kind of delay by the postal authorities or any technical issue of website.
7. The Tenderer should submit tender cost along with self attested photo copies of above documents. The Envelope-I / Enclosure (Technical) will contain complete tender document along with all above required documents, EMD and cost of tender documents. The Envelope -II / Enclosure (Financial) will contain only financial Bid, otherwise, the offer shall not be considered and OCCL will not be responsible for missing of any pages .
8. The Bid documents (technical bid & price bid) submitted through e-mail by the bidders must be password protected & the password is to be set by the Bidder himself.

**Signature of the Tenderer agency or
His/their Power of attorney holder
with designation & seal.**

**Senior Manager (Mech.)-I
OCC Ltd, Central Workshop,
Rasulgarh, Bhubaneswar-10.**

9. The Bid documents (technical bid & price bid) will be opened in presence of the interested bidders on the scheduled date and time as mentioned in the tender.
10. The password is to be revealed or intimated by the tenderer or Bidder at the time of opening of price Bid documents.
11. The Bids received through e-mail without password will be out-rightly rejected.
12. The tenderer who will participate through email (**smcwsoccltender@gmail.com**), must upload all the self attested technical Bid documents in one Enclosure (Technical) and the Price schedule in another Enclosure (Financial). The tenderer (participated through e-mail) will scan the relevant documents and upload the same along with password protection. Subject of the Email should be **“Tender for Supply of Rope drum, drum gear, first pinion, second gear in casting condition, bush for pulley, bronze bush and pulley in finished condition respectively for 25T gantry crane of Lower Suktel Irrigation Project ”**.
13. Original copy of tender, tender paper cost must submitted to the undersigned within 05(five) days of opening of tender, otherwise bid shall be rejected and the Bidder will be debarred for participation in any future tender.
14. The tenders will be received and opened in the office of the undersigned as per the information in the table of tender call notice in presence of the Tenderer or their authorized representatives, if they so desire.
15. If there will be a public holiday on the last date of sale of tender document and receipt & opening of the tenders as specified above, the tender document will be sold and tenders will be received & opened on the next working day at the same time and venue.
16. The tenderer should quote appropriate taxes with the offer.
17. The rates and amounts should be quoted both in figures and words in the price schedule. Any correction or overwriting in the specification and price schedule should be duly certified by the tenderer or his power of attorney holder. In case of any mismatch in figures and words, the rates in words will be considered. In case of any mismatch in rates and amount, the rate will be considered.
18. The materials should be supplied in finished / fully machined conditions by successful tenderer / supplier as per required dia, length and quantity and should strictly conform to relevant standards of Bureau of Indian Standard (BIS) as mentioned in detailed specification and price schedule.
19. The original test certificate of materials from a Govt./Govt. approved testing laboratory will be provided by the successful tenderer/ supplier along with supply of materials. The manufacturer’s test certificate will have to be also furnished by the successful tenderer/ supplier. The purchaser is having the option to test the materials in any laboratory at the cost of the supplier and if the materials are not found in accordance with the specifications and grade in relevant Indian Standards, the materials will be rejected.
20. The materials will be guaranteed by the supplier against any defect for a period of 18 months from the date of supply or 12 months from the date of use, whichever is earlier. Guarantee certificate in this regard will accompany with supply of materials. If any defect is found in the materials within the guarantee period, the same will have to be replaced free of cost by the supplier.
21. The rate of materials should be quoted by the tenderer on unit basis only. The same should be supplied by the successful supplier as per required dia, length and quantity in numbers as mentioned in detail specification and Price Schedule.

**Signature of the Tenderer agency or
His/their Power of attorney holder
with designation & seal.**

- 5 -

**Senior Manager (Mech.)-I
OCC Ltd, Central Workshop,
Rasulgarh, Bhubaneswar-10.**

22. The tenderer will quote their rates F.O.R. OCCL Store, Central Workshop, Rasulgarh, Bhubaneswar-10 (Odisha) indicating separately the basic price, packing, forwarding, transportation, transit insurance, handling charges, taxes, duties, levies etc. strictly in the specifications and price schedule format in original. All columns and lines of the specification and price schedule should be filled in properly without leaving any thing blank. The details and rates of duties, taxes etc. should be indicated clearly in the specification and price schedule.
- 7) The authority has the option to conduct Pre-delivery inspection (P.D.I) before despatch of the materials will be made at the manufacturer's works by the authorized representative of the purchaser for which the manufacturer should intimate in writing for P.D.I. 10 days in advance regarding readiness for P.D.I.
- 8) 90% payment will be made within 30 days of receipt, verification and acceptance of the complete materials along with bill, test certificate, guarantee certificate and other documents. Balance 10% will be released after 18 months of supply or 12 months from the date of commissioning whichever is earlier. However if a performance bank guarantee is received for 10% of the value of materials, the same will be released within 60 days from the date of receipt of materials.
- 9) The purchaser reserves the right to forfeit and encash the performance bank guarantee / EMD in full in case any casting is found defective and not replaced by the tenderer/supplier within a suitable time fixed by the corporation. Any repair to the casting shall be made only after approval of the purchaser. In this connection, the decision of the purchaser is final and binding on the tenderer/supplier.
- 10) Price escalation will not be allowed under any circumstances. The quoted rates will remain firm till execution of the work order.
- 11) The validity of the offer should be for a period of 120 (One hundred twenty) days from the date of opening of the tender.
- 12) The complete ordered quantity shall be supplied by the successful tenderer within 60 (Sixty) days from the date of issue of purchase order failing which the order is liable for cancellation without assigning any reason thereof by the purchaser. In case of cancellation of the order the EMD will be forfeited. In case of any delay in supply of material beyond the delivery schedule whatever may be the reason, supplier shall be liable to pay L.D. @ 0.5% (Half percent) of the total order value per week of delay or part thereof subject to a maximum of 5% (Five percent) of the total order value.
- 13) After submission of tender and before placing order, the bidder may be asked by the undersigned to attend techno-commercial discussions and reply to queries within a specified period. If the bidder fail to do so, the tender submitted by the bidder is liable to be cancelled.
- 14) Conditional offers with deviations will not be accepted. Those, who do not agree to the terms and conditions regarding payments, delivery and others, need not quote.
- 15) The authority reserves the right to accept/reject any or all tenders without assigning any reason thereof. The required quantity of materials can be splitted among the two or more tenderers. In this connection, the decision of purchaser is final and binding on the tenderer.
- 16) The duplicate copy of the order shall be signed by the supplier on each page with his seal as acceptance of the order and shall be returned to the purchaser within 07 (Seven) days of receipt of this order failing which the order is liable for cancellation.
- 17) Any dispute arising out of this tender or order thereof is to be settled in proper court under the jurisdiction of Odisha High Court at Cuttack or courts under the jurisdiction of Odisha High Court at Bhubaneswar only.

**Signature of the tenderer or his/their
power of attorney holder
with designation & seal.**

**Senior Manager (Mech.)-I
OCC Ltd, Central Workshop,
Rasulgarh, Bhubaneswar-751010**

ODISHA CONSTRUCTION CORPORATION LIMITED
(A GOVT. OF ODISHA UNDERTAKING)
CENTRAL WORKSHOP, RASULGARH,
BHUBANESWAR-751010 (ODISHA).

DETAILED SPECIFICATION AND PRICE SCHEDULE FOR
“ Supply of Rope drum, drum gear, first pinion, second gear in casting condition, bush for pulley, bronze bush and pulley in finished condition respectively for 25T gantry crane of Lower Suktel Irrigation Project ”
VIDE TCN No.OCC/CWS/PROC/ LSIP-21 / 06 /2026-27 DATED 02.05.2026 DUE DATE OF OPENING ON DATED 15.05.2026

Sl. No.	Part No.	Description of Item	Unit	Qty. Reqd. in unit	Rate per unit in Rs.				Total amount in Rs. for full materials	
					Basic Price per unit	GST as applicable	Total in figures	Total in words	In figure	In words
1	3-1	Rope Drum in casting condition of Material-Cast steel GR. 340-570W of IS:1030-1989, As per Drawing(Annexure-1)	Nos.	2						
2	3-3	Bronze Bush in finished condition of material- Leaded Tin Bronze Gr. LTB-1 of IS:318-1981,As per Drawing(Annexure-2)	Nos.	4						
3	4-1	Drum Gear in casting condition of material- High Strength Steel Casting Gr.3 CS-840 of IS:2644-1994,As per Drawing(Annexure-3)	Nos.	2						
4	4-2	First pinion in casting condition of material- High Strength Steel Casting Gr.4 CS-1030 of IS:2644-1994 ,As per Drawing(Annexure-4)	Nos.	2						
5	4-3	Second Gear in casting condition of Material-High Strength Steel Casting Gr.3 CS-840 of IS:2644-1994 , As per Drawing(Annexure-5)	Nos.	2						
6	4-4	Second pinion in casting condition of Material High Strength Steel Casting Gr.4 CS-1030 of IS:2644-1994, As per Drawing(Annexure-6)	Nos.	2						
7	4-5	Pulley in finished condition of Material Cast steel Gr.340-570W of IS:1030-1998 , As per Drawing(Annexure-7)	Nos.	4						
8	4-6	Bush for pulley in finished condition of Material-LTB -1 OF IS:318-1981, As per Drawing (Annexure-VIII)	Nos.	8						

N.B : 1) Price should be inclusive of P&F, trans., transit insurance, handling charges, incidental charges etc

**Signature of the tenderer or his/their
power of attorney holder
with designation & seal.**

**Senior Manager (Mech.)-I
OCC Ltd, Central Workshop,
Rasulgarh, Bhubaneswar-751010**

FOR TENDER PURPOSE ONLY

A

A

END VIEW

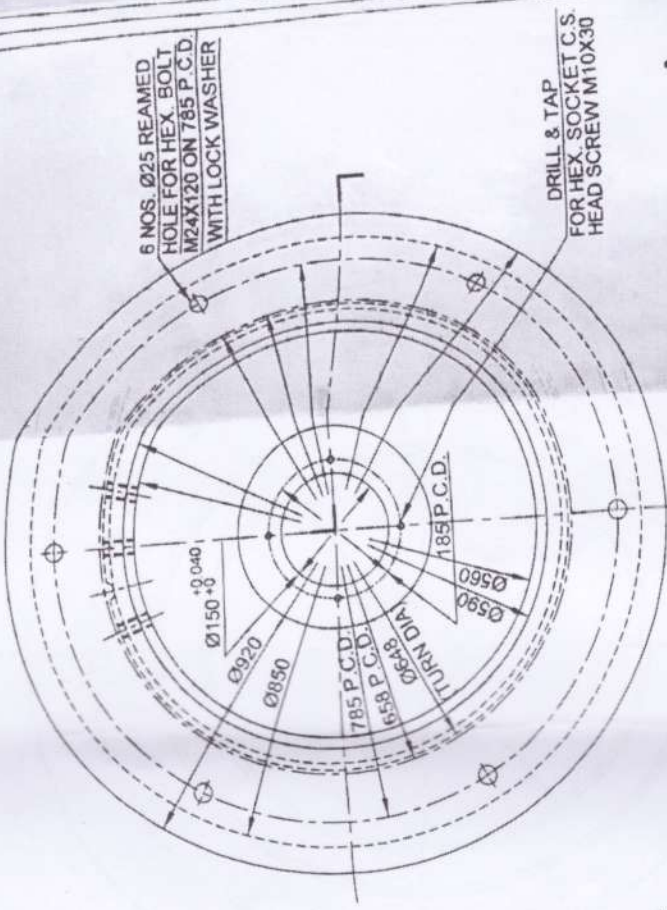

NOTES :-

1. ALL DIMENSIONS ARE IN MM OF THE FINISHED PART.
2. ALL CASTING SHALL BE SUPPLIED IN FULLY ANNEALED CONDITION & SUITABLY HEAT TREATED SO AS TO ATTAIN SPECIFIED MECHANICAL PROPERTIES.
3. SUITABLE MACHINING ALLOWANCES (NOT LESS THAN 5 mm ON TOOL POINT) SHALL BE PROVIDED ON ALL SURFACES INDICATED TO BE MACHINED.
4. THE FINISHES AND TOLERANCES SHOWN ARE FOR THE FINISHED PART.
5. ONE LEFT DRUM ASSEMBLY & ONE RIGHT DRUM ASSEMBLY SHALL CONSTITUTE ONE SET.
6. DRILL & TAP FOR HEX. SOCKET C.S. HEAD SCREW M10X30 SHALL BE DONE ALONG WITH THE MATCHING PART.
7. THE MATCHING PART SHALL BE FREE FROM DEFECTS THAT WILL ADVERSELY AFFECT ITS UTILITY & SHALL BE TESTED ULTRASONICALLY.
8. REAMED HOLE FOR M24 BOLT SHALL BE MADE ALONG WITH THE MATCHING PART OF DRUM GEAR.

LOWER SUKTEL IRRIGATION PROJECT

PREPARED	<i>Chatterjee</i>
DRAWN	<i>Kalyan</i>
CHECKED	<i>Shubho</i>
SUBMITTED	<i>Pranav</i>
RECOMMENDED	<i>Pranav</i>

25 T GANTRY CRANE FOR SPILLWAY STOPLOGS

ROPE DRUM

O.C.C.LTD.

MARCH 2025

DRG.NO.-07-17-07-01-03-01

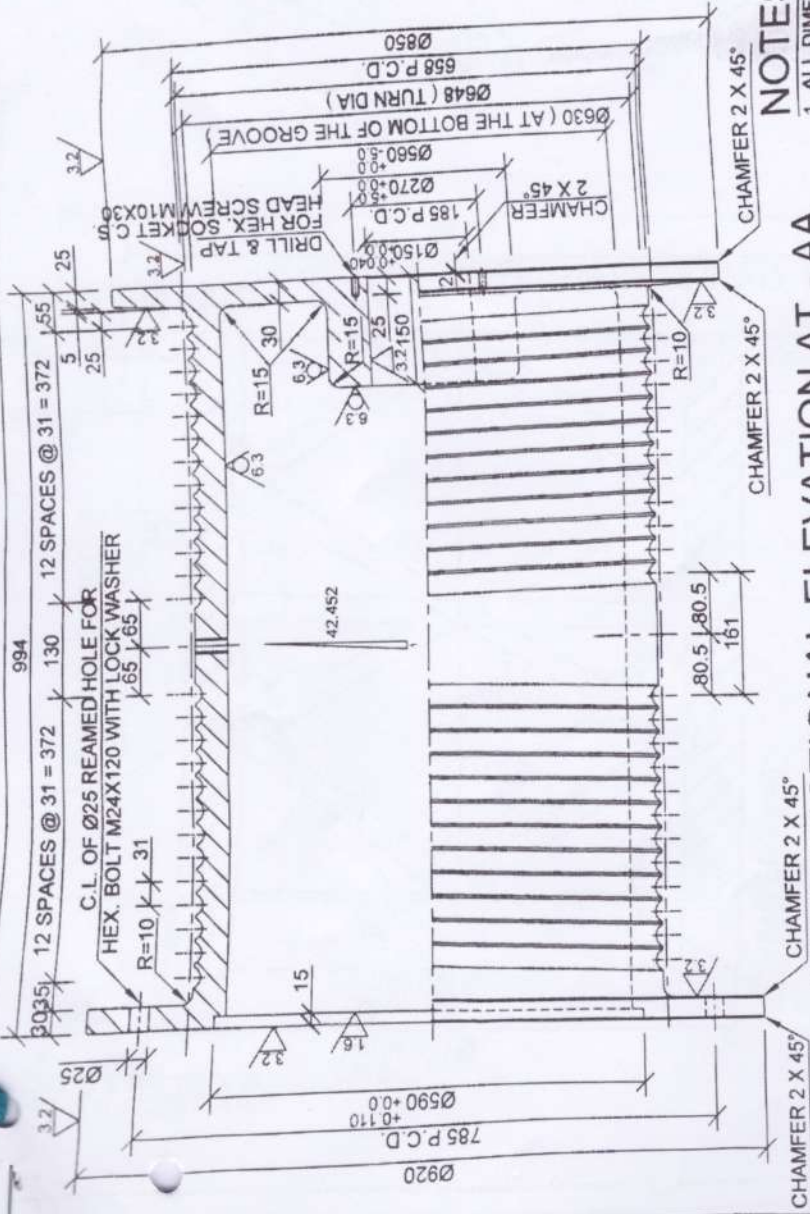

U/S VIEW OF RIGHT ROPE DRUM

PART NO. - 07-17-07-00-03-01
 MATERIAL :- CAST STEEL GR. 340-570W OF IS:1030-1989
 TOTAL NOS. REQD. - ONE SET (1 LEFT, 1 RIGHT)

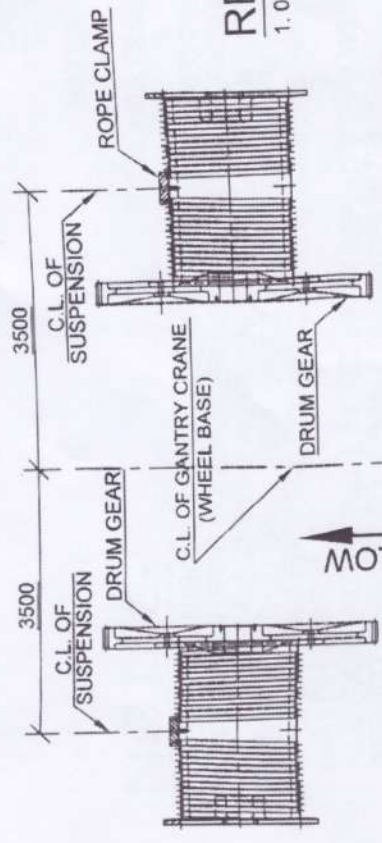

LEFT DRUM

RIGHT DRUM

KEY PLAN

REF. DRG. NOS. :-

1. 07-17-07-00-03

FOR TENDER PURPOSE ONLY

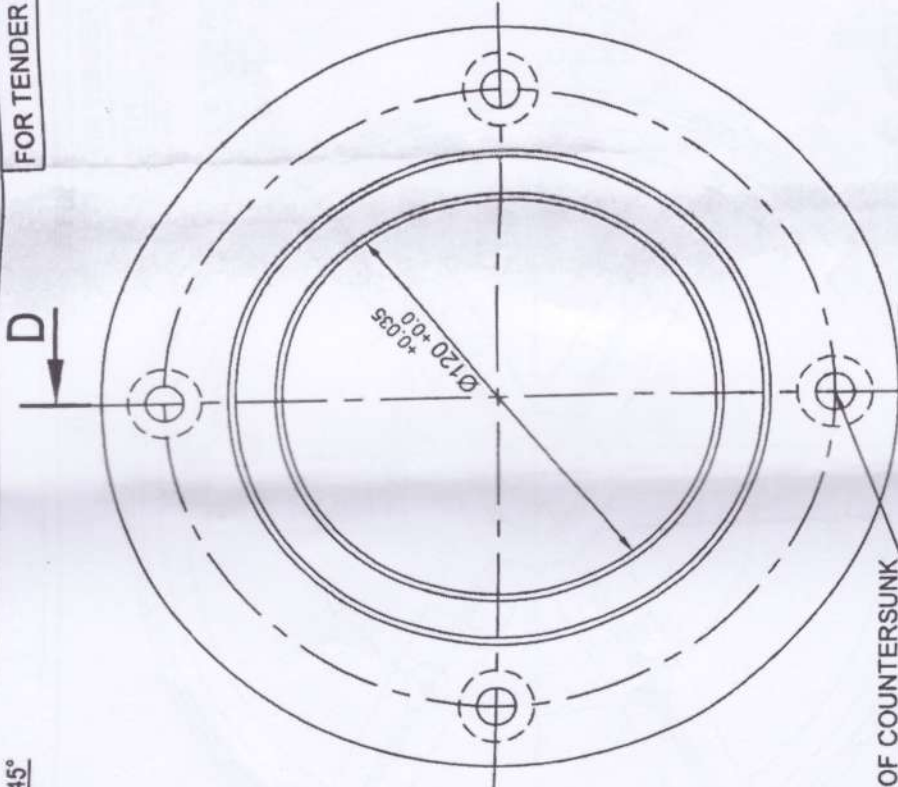

REF. DRGS. NO.:-
1. 07-17-07-00-03

END VIEW

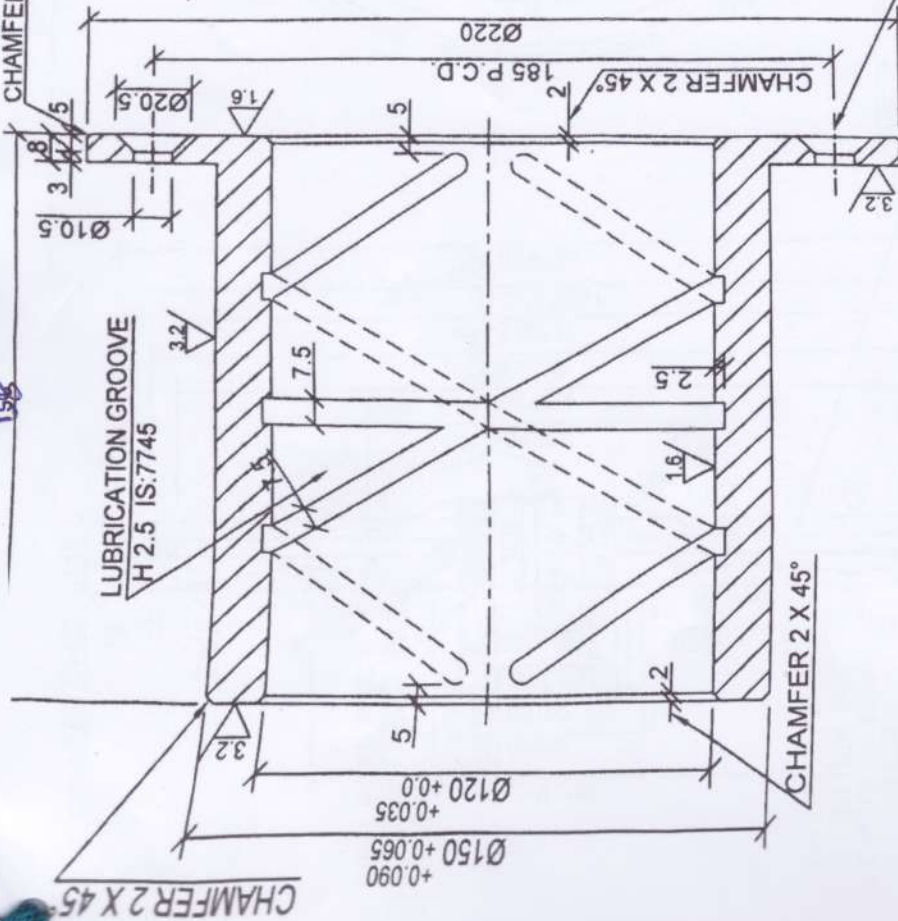

SECTION - DD

BRONZE BUSH

PART NO.- 07-17-07-00-03-03

MATERIAL :- LEADED TIN BRONZE

GR. LTB -1 OF IS:318-1981

TOTAL NOS. REQD. - ONE SET (2 LEFT, 2 RIGHT)

NOTES-

1. ALL DIMENSIONS SHOWN ARE IN mm OF THE FINISHED PART.
2. THE FINISHES & TOLERANCES INDICATED ARE FOR FINISHED PART ONLY.
3. SUITABLE MACHINING ALLOWANCE (NOT LESS THAN 5mm ON TOOL POINT) SHALL BE PROVIDED ON ALL SURFACES INDICATED FOR MACHINING.
4. DRILL & TAP FOR HEX. SOCKET C.S. HEAD SCREW SHALL BE DONE ALONG WITH THE MATCHING PART.
5. ALL CASTINGS SHALL BE FREE FROM DEFECTS THAT WILL ADVERSELY AFFECT THE UTILITY & SHALL BE TESTED ULTRASONICALLY.
6. THE MATERIAL SHALL BE TESTED FOR CHEMICAL COMPOSITION & MECHANICAL PROPERTIES REPRESENTATIVE OF EACH MELT.

LOWER SUKTEL IRRIGATION

PROJECT

25 T GANTRY CRANE FOR SPILLWAY
STOPLOGS

BRONZE BUSH

O.C.C.LTD.

PREPARED	<i>Chatterjee</i>
DRAWN	<i>Nayak</i>
CHECKED	<i>Sharma</i>
SUBMITTED	<i>Prasad</i>
RECOMMENDED	<i>Alam</i>

MARCH
2025

DRG.NO.-07-17-07-01-03-03

SCALE:1

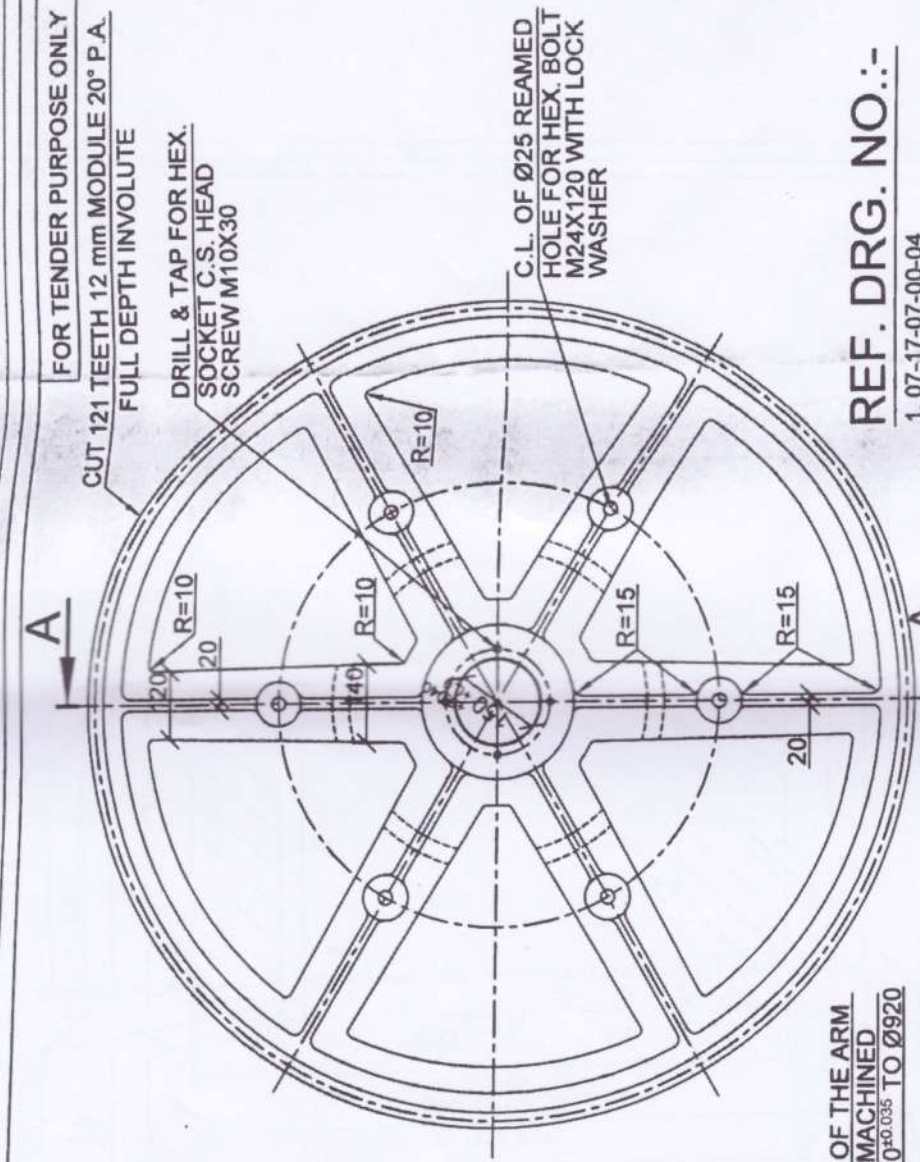

END VIEW

REF. DRG. NO. :-
1. 07-17-07-00-04

O.C.C.LTD.	
PREPARED	<i>C. Chatterjee</i>
DRAWN	<i>N. Rayak</i>
CHECKED	<i>S. Ghosh</i>
SUBMITTED	<i>V. Ghosh</i>
RECOMMENDED	<i>A. Ghosh</i>
LOWER SUKTEL IRRIGATION PROJECT	
25 T GANTRY CRANE FOR SPILLWAY STOPLOGS	
DRUM GEAR	
MARCH 2025	DRG. NO. 07-17-07-01-04-01

SCALE=1:2.5

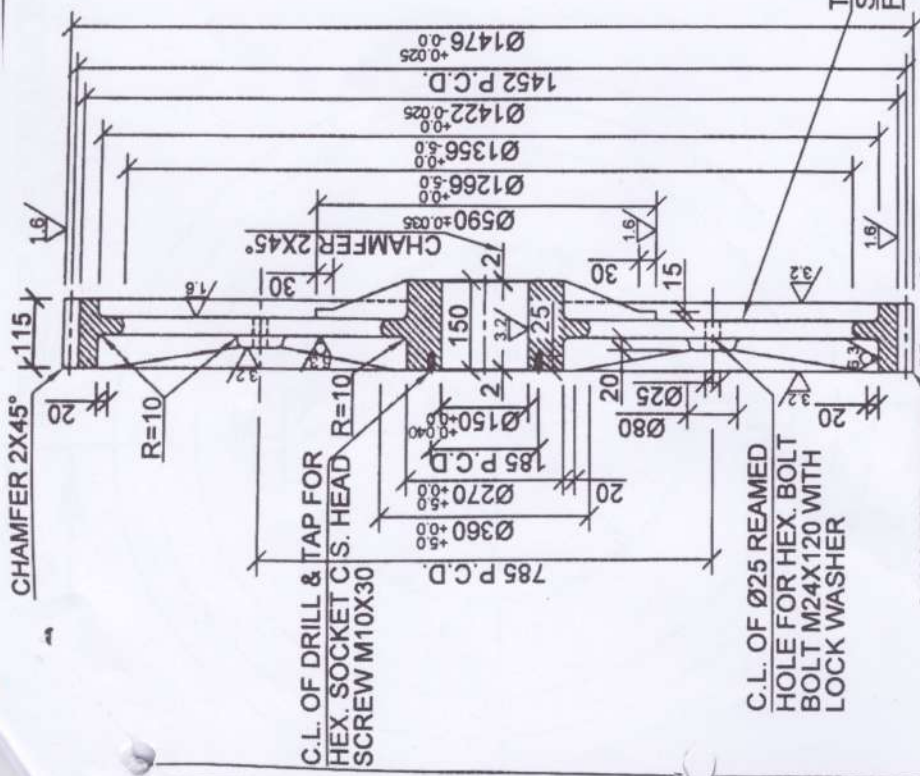

DRUM GEAR

PART NO. - 07-17-07-00-04-01
MATERIAL - HIGH STRENGTH STEEL CASTING
GR.3 - CS 840 OF IS:2644 - 1994
TOTAL NOS. REQD. = 02 (TWO)

NOTES:-

1. ALL DIMENSIONS ARE IN mm OF THE FINISHED PART.
2. THE FINISHES AND TOLERANCES GIVEN ARE FOR THE FINISHED PART ONLY.
3. SUITABLE MACHINING ALLOWANCES (NOT LESS THAN 5 mm ON TOOL POINT) SHALL BE PROVIDED ON ALL SURFACES INDICATED TO BE MACHINED.
4. THE CASTING SHALL BE SUPPLIED IN FULLY ANNEALED CONDITION & SUITABLY HEAT TREATED SO AS TO ATTAIN THE SPECIFIED MECHANICAL PROPERTIES.
5. THE CASTING SHALL BE FREE FROM DEFECTS THAT WILL ADVERSELY AFFECT MACHINING OR UTILITY OF THE CASTING & SHALL BE TESTED ULTRASONICALLY.
6. DRILL & TAP FOR HEX. SOCKET C.S. HEAD SCREW M10X30 SHALL BE DONE ALONG WITH THE MATCHING PART.

CUT 74 TEETH 10mm MODULE 20° P.A.
FULL DEPTH INVOLUTE

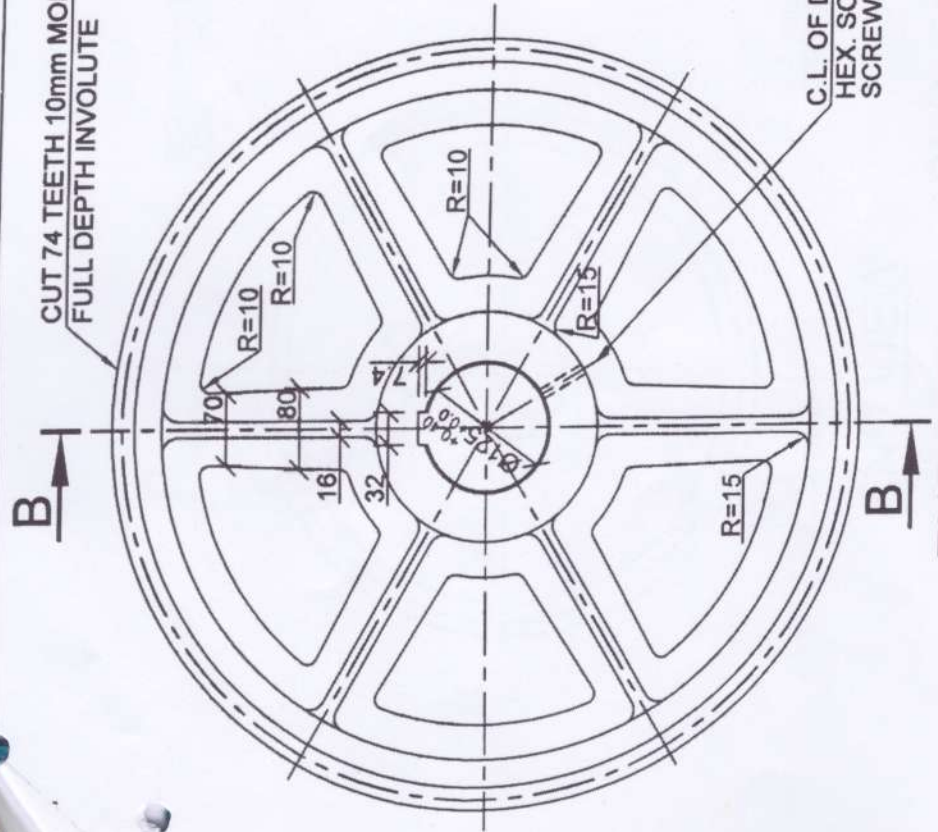

END VIEW

C.L. OF DRILL & TAP FOR
HEX. SOCKET SET
SCREW M10X45 - 45H

2ND. GEAR

PART NO.- 07-17-07-00-04-03
MATERIAL - HIGH STRENGTH STEEL CASTING
GR.3 - CS 840 OF IS:2644 -1994
TOTAL NOS. REQD. = 02 (TWO)

NOTES:-

1. ALL DIMENSIONS ARE IN mm OF THE FINISHED PART.
2. THE FINISHES AND TOLERANCES GIVEN ARE FOR THE FINISHED PART ONLY.
3. SUITABLE MACHINING ALLOWANCES (NOT LESS THAN 5 mm ON TOOL POINT) SHALL BE PROVIDED ON ALL SURFACES INDICATED TO BE MACHINED.
4. THE CASTING SHALL BE SUPPLIED IN FULLY ANNEALED CONDITION & SUITABLY HEAT TREATED SO AS TO ATTAIN THE SPECIFIED MECHANICAL PROPERTIES.
5. THE CASTING SHALL BE FREE FROM DEFECTS THAT WILL ADVERSELY AFFECT MACHINING OR UTILITY OF THE CASTING & SHALL BE TESTED ULTRASONICALLY.
6. DRILL & TAP FOR HEX. SOCKET SET SCREW M10X45 SHALL BE DONE ALONG WITH THE MATCHING PART.

FOR TENDER PURPOSE ONLY

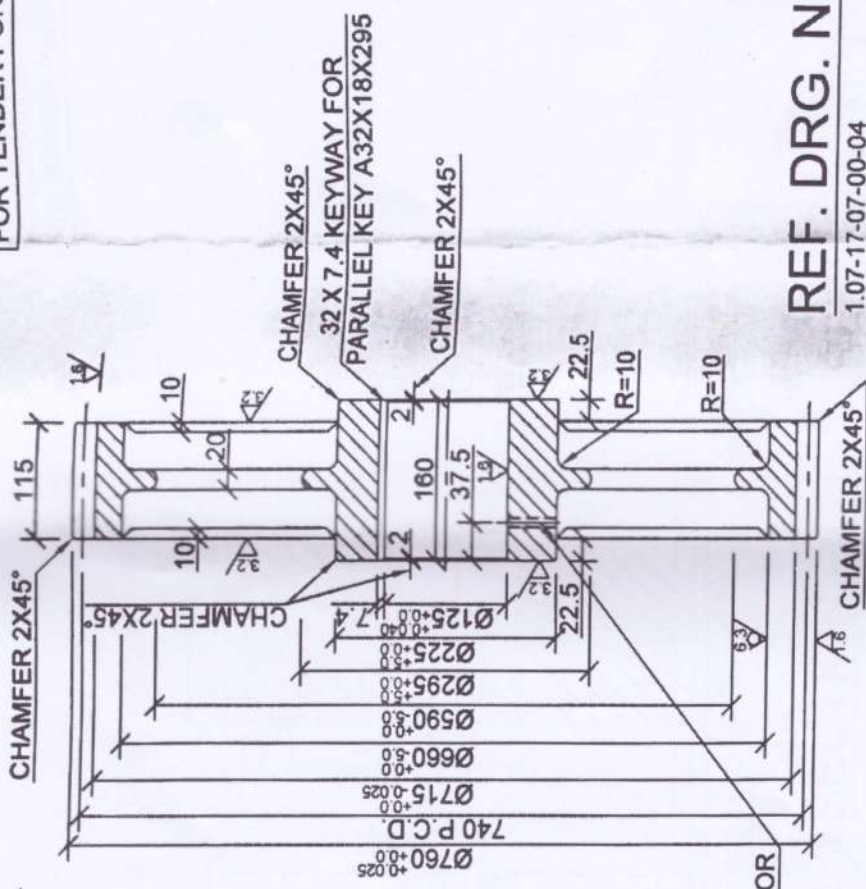

SECTION - BB

REF. DRG. NO. :-
1.07-17-07-00-04

LOWER SUKTEL IRRIGATION PROJECT		O.C.C.LTD.	
25 T GANTRY CRANE FOR SPILLWAY STOPLOGS		PREPARED	<i>Chatterjee</i>
2ND. GEAR		DRAWN	<i>Rayat</i>
		CHECKED	<i>Sharma</i>
		SUBMITTED	<i>Vijay</i>
MARCH 2025		RECOMMENDED	<i>Arora</i>
DRG.NO.-07-17-07-01-04-03			

FOR TENDER PURPOSE ONLY

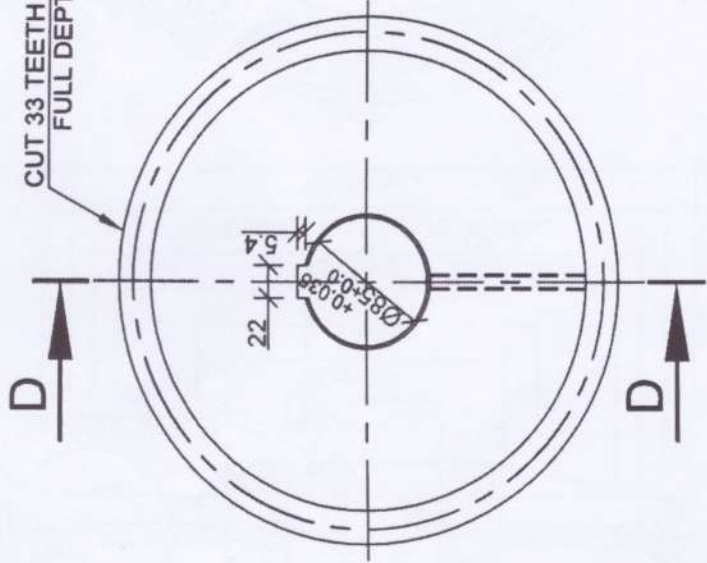
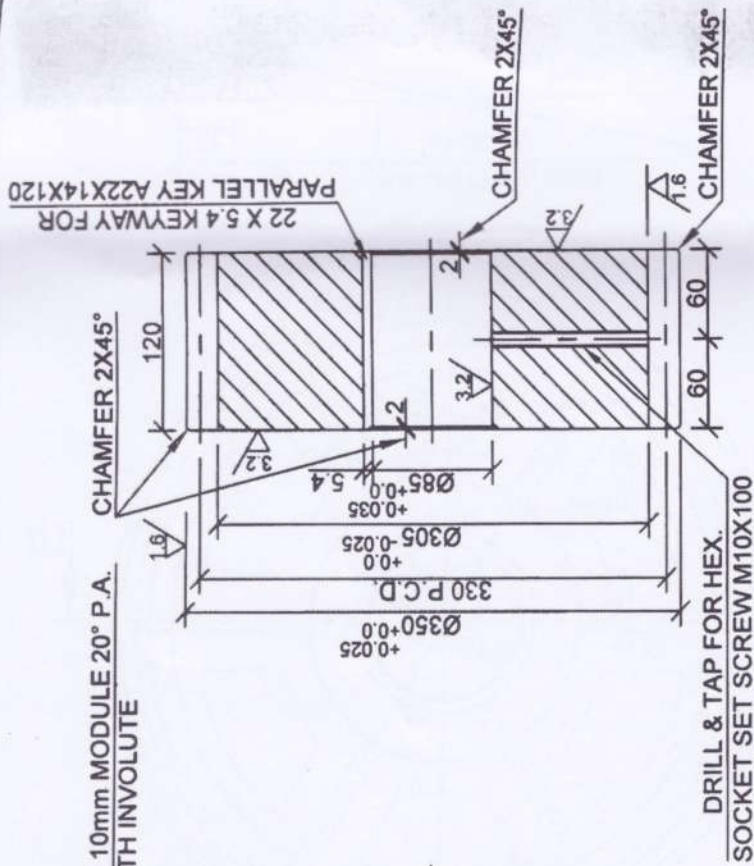

SECTION - DD

END VIEW

REF. DRG. NO. :-
1.07-17-07-00-04

2ND. PINION

PART NO. - 07-17-07-00-04-04
MATERIAL - HIGH STRENGTH STEEL CASTING
GR.4 - CS 1030 OF IS:2644 - 1994
TOTAL NOS. REQD. = 02 (TWO)

NOTES:-

1. ALL DIMENSIONS ARE IN mm OF THE FINISHED PART.
2. THE CASTING SHALL BE FREE FROM DEFECTS THAT WILL ADVERSELY AFFECT ITS UTILITY & SHALL BE TESTED ULTRASONICALLY.
3. SUITABLE MACHINING ALLOWANCES (NOT LESS THAN 5 mm ON TOOL POINT) SHALL BE PROVIDED ON ALL SURFACES INDICATED FOR MACHINING.
4. THE FINISHES AND TOLERANCES GIVEN ARE FOR THE FINISHED PART ONLY.
5. DRILL & TAP FOR HEX. SOCKET SET SCREW M10X100 SHALL BE DONE ALONG WITH THE MATCHING PART.
6. CASTING SHALL BE SUPPLIED IN FULLY ANNEALED CONDITION & SUITABLY HEAT TREATED SO AS TO ATTAIN SPECIFIED MECHANICAL PROPERTIES.

<p>LOWER SUKTEL IRRIGATION PROJECT</p> <p>25 T GANTRY CRANE FOR SPILLWAY STOPLOGS</p> <p>2ND. PINION</p>	<p>O.C.C.LTD.</p>	
	PREPARED	<i>Chatterjee</i>
	DRAWN	<i>Rayan</i>
	CHECKED	<i>Sydehant</i>
	SUBMITTED	<i>Prady</i>
	RECOMMENDED	<i>Chatterjee</i>
<p>MARCH 2025</p>		<p>DRG.NO.- 07-17-07-01-04-04</p>

FOR TENDER PURPOSE ONLY

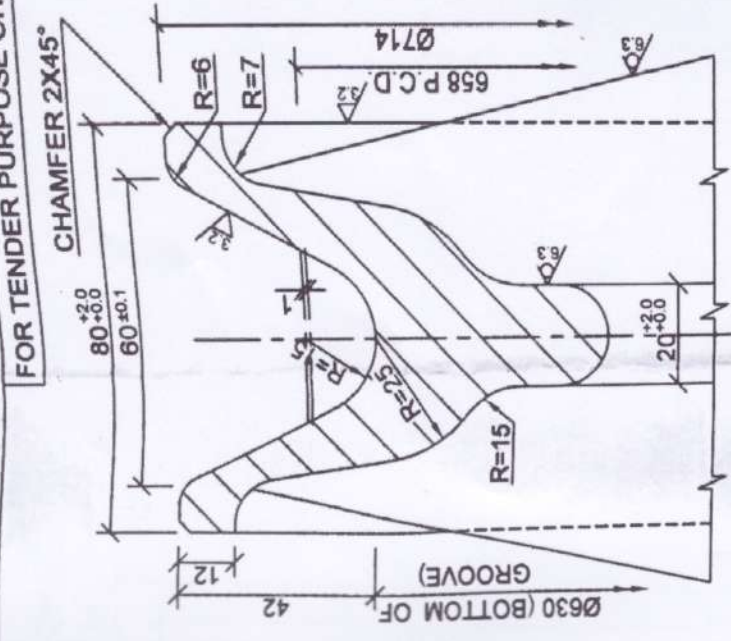

DETAIL - X

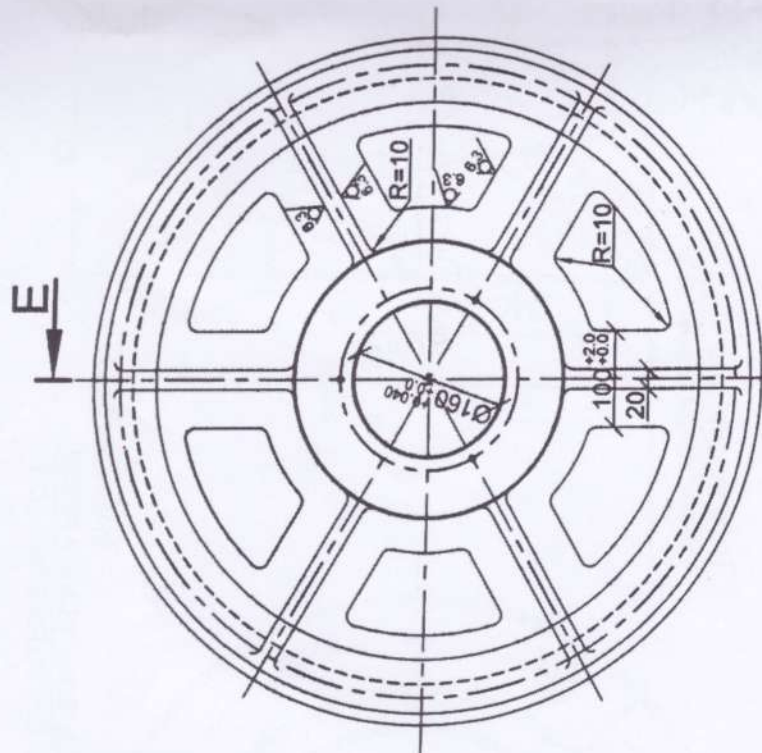

END VIEW

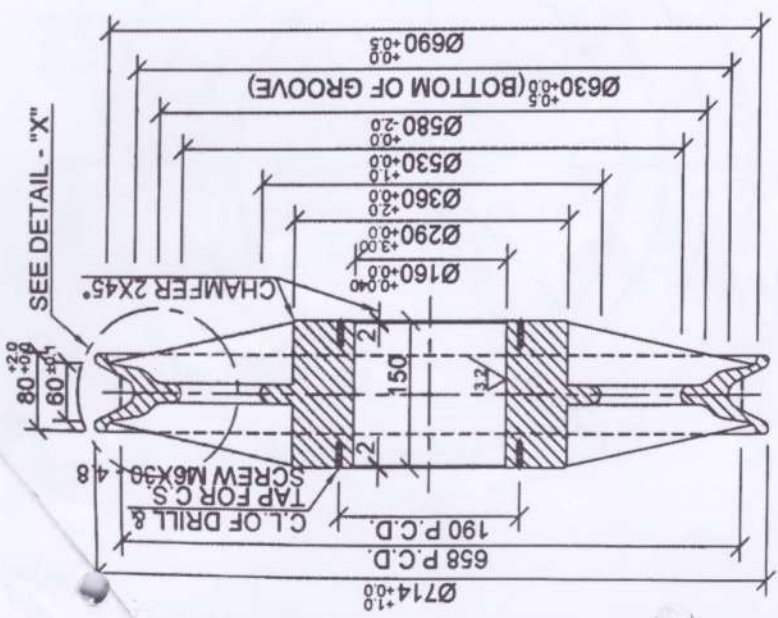

SECTION - EE

REF.DRG. NO.:-
1.07-17-07-00-04

PULLEY

PART NO. - 07-17-07-00-04-05
MATERIAL - CAST STEEL GR.340 - 570W
OF IS:1030 - 1998
TOTAL NOS. REQD. = 04 (FOUR)

NOTES:-

1. ALL DIMENSIONS ARE IN MM OF THE FINISHED PART.
2. THE FINISHES AND TOLERANCES GIVEN ARE FOR THE FINISHED PART ONLY.
3. SUITABLE MACHINING ALLOWANCES (NOT LESS THAN 5 mm ON TOOL POINT) SHALL BE PROVIDED ON ALL SURFACES INDICATED FOR MACHINING.
4. THE CASTING SHALL BE SUPPLIED IN FULLY ANNEALED CONDITION & SUITABLY HEAT TREATED SO AS TO ATTAIN THE SPECIFIED MECHANICAL PROPERTIES.
5. THE CASTING SHALL BE FREE FROM DEFECTS THAT WILL ADVERSELY AFFECT MACHINING OR UTILITY OF THE CASTING & SHALL BE TESTED ULTRASONICALLY.
6. DRILL & TAP FOR C.S. SCREW M6X30 SHALL BE DONE ALONG WITH THE MATCHING PART.

O.C.C.LTD.	
PREPARED	<i>Chatterjee</i>
DRAWN	<i>Rayak</i>
CHECKED	<i>Syambhu</i>
SUBMITTED	<i>Prasen</i>
RECOMMENDED	<i>Kumar</i>

LOWER SUKTEL IRRIGATION PROJECT

25 T GANTRY CRANE FOR SPILLWAY STOPLOGS

PULLEY

MARCH 2025

DRG.NO.- 07-17-07-01-04-05

