

ODISHA CONSTRUCTION CORPORATION LIMITED
(A GOVT. OF ODISHA UNDERTAKING)
CENTRAL WORKSHOP, RASULGARH,
BHUBANESWAR-751010 (ODISHA)

* * * * *

TENDER DOCUMENT FOR
“SUPPLY OF CASTING ITEMS FOR VARIOUS GATE WORKS PROJECT ”

The tender document comprises of the following:

1)	Tender call notice No. OCC/CWS/PROC/ KBP-02(P-I)/ 72 /2023-24 dated.26.02.2024	01 (One) sheet
2)	Terms and conditions	04 (Four) sheets
3)	Drawings	21 (Twenty one) sheets
4)	Price schedule	03 (Three) sheet
----- Total :		29 (Twenty nine) sheets -----

**Signature of the tenderer or his/their
power of attorney holder
with designation & seal.**

**Senior Manager (Mech.)-I
OCC Ltd, Central Workshop,
Rasulgarh, Bhubaneswar-751010**

ODISHA CONSTRUCTION CORPORATION LIMITED
(A GOVT. OF ODISHA UNDERTAKING)
CENTRAL WORKSHOP, RASULGARH,
BHUBANESWAR-751010 (ODISHA)

TENDER CALL NOTICE No. OCC/CWS/PROC/ KBP-02(P-I) / 72 /2023-24 dated. 26.02.2024

Sealed tenders in conformity with the terms, conditions, drawing and technical specifications in tender documents are invited from reputed manufacturers / traders for “**Supply of casting items for various gate works project**” as per details below:

Cost of tender document (Non-refundable)	Sale of tender document		Earnest money deposit (EMD) required	Receipt of tender	Opening of Technical & price bid of tender
Rs. 2000/- GST @ 18% Rs.2360/- by hand & Rs.2460/- by Regd. Post/ courier	From 27.02.2024	To 04.03.2024 up to 1.00 PM	1(One)% of the total quoted value including GST	Up to 3.30 P.M. on 04.03.2024	At 4.00 PM on 04.03.2024

The tender document can be purchased by the interested reputed manufacturers or their authorized dealers / traders by hand from the office of the undersigned on deposit of cost of tender document i.e. **Rs.2000/-** plus GST @ 18% amounting to **Rs.2360/-** in cash or in shape of A/c. payee demand draft drawn in favour of “Odisha Construction Corporation Limited” - Project Account on any Nationalised Bank/ Scheduled Bank payable at Bhubaneswar (Non-refundable) and production of attested copies of the following documents and verification thereof by the undersigned. The tender document can also be obtained by the interested reputed manufacturers or their authorized dealers / traders by registered post, speed post/ courier on sending the cost of tender document i.e. **Rs.2000/-** plus GST @ 18% and postage charges of **Rs.100/-** amounting to **Rs.2460/-** in shape of A/c. payee demand draft drawn as stated above and attested copies of the following documents and verification thereof by the undersigned. The undersigned will not be responsible for any kind of delay by the postal/courier authorities.

- 1) Valid GST Registration Certificate.
- 2) PAN Card
- 3) The bidders have to submit copies of purchase orders, credentials, certificates etc. in support of supply of similar items of magnitude minimum amounting to 5.00 lakh in last 5 financial years (i.e. from financial year 2018-19 to 2022-23 including current financial year 2023-24).
- 4) Tenderer should submit valid manufacturer / trader registration certificate.

The tender document can also be downloaded from our Website www.odishaconstruction.com or Govt. of Odisha website www.odishagov.nic.in to submit the tender (**Bidders are requested to visit our website regularly for any changes**). However, the cost of tender document i.e **Rs.2000/-** plus GST @ 18% amounting to **Rs.2360/-** in shape of A/c payee demand draft as stated above in favour of “Odisha Construction Corporation Limited” - Project Account on any Nationalised Bank/ Scheduled Bank payable at Bhubaneswar (Non-refundable) along with attested photo copies of all above documents should be submitted while submitting the tender in Envelope-I. Otherwise, the offer shall not be considered and OCCL will not be responsible for missing of any page while downloading. If there will be a public holiday on the last date of sale of tender document and receipt & opening of the tender as specified above, the tender document will be sold and tender will be received & opened on the next working day at the same time and venue.

The SSI/NSIC/MSME units participating in tender are not entitled for exemption from payment of EMD / Tender Paper costs as communicated vide DOWR Letter No. IIM-24/2018-14318/WR dated 24.05.2018 & Head Office, OCCL Letter No.5502/OCC/ CW-02/09(Vol-V)(WE) dated 30.05.2018.

The tenders will be opened in the presence of the tenderers or their authorised representatives. Tender through Fax/Telex/telegram/e-mail will not be accepted

The undersigned reserves the right to accept or reject any or all quotations without assigning any reason thereof

Signature of the tenderer or his/their
power of attorney holder
with designation & seal.

Senior Manager (Mech.)-I
OCC Ltd, Central Workshop,
Rasulgarh, Bhubaneswar-751010

ODISHA CONSTRUCTION CORPORATION LIMITED

(A GOVT. OF ODISHA UNDERTAKING)

CENTRAL WORKSHOP, RASULGARH,

BHUBANESWAR-751010 (ODISHA)

TERMS AND CONDITIONS OF TENDER FOR

“SUPPLY OF CASTING ITEMS FOR VARIOUS GATE WORKS PROJECT”

- 1) Reputed manufacturers/ traders having supplied similar item of similar magnitude earlier and satisfactorily accepted by the clients will be eligible to participate in the tender. The copies of purchase orders, credentials, certificates etc. in support of similar supply and satisfactory performance thereof will be furnished along with the tender.
- 2) Tender should be submitted in two bid system in two separate sealed covers and both will be submitted in a single sealed outer cover subscribing in bold letters as **“Supply of casting items for various gate works project”** and also date of opening of tender. The name and address of the tenderer should not be written on outer cover. Only the name and address of the purchaser should be written on the outer cover.
- 3) The tenderer should submit Earnest Money Deposit (EMD) @ 1(One)% of the total quoted value along with the tender in shape of A/C payee Demand Draft drawn in favour of “Odisha Construction Corporation Limited” - Project Account on any Nationalised Bank / Scheduled bank payable at Bhubaneswar. The tenders received without EMD will be out rightly rejected. EMD of the unsuccessful tenderers will be released only after finalization of the tender.
- 4) i) The first envelope super scribing in bold letters as **“TECHNICAL BID”** should contain the following:
 - a. EMD of 1% as per clause- 3 above.
 - b. Attested copy of valid GST registration certificates. The tenderer will mention his GST Regn. No. in his tender clearly without which the tender will not be taken into consideration.
 - c. Attested copy of PAN Card.
 - d. The bidders have to submit copies of purchase orders, credentials, certificates etc. in support of supply of similar items of magnitude minimum amounting to 05.00 lakh in last 5 financial years (i.e. from financial year 2018-19 to 2022-23 including current financial year 2023-24).
 - e. Complete tender document in original including terms and conditions but without detailed specifications and price schedule duly signed on each page by the tenderer or his/their power of attorney holder. In case of power of attorney holder, an attested copy of power of attorney should be furnished.ii) Second envelope subscribing in bold letters **“SPECIFICATION AND PRICE SCHEDULE”** should contain detailed specifications and price schedule in original only duly filled in without leaving any column and line blank and signed on each page by the tenderer or his/their power of attorney holder.
- 5) The tender document can be purchased by the interested reputed manufacturers / traders by hand from the office of the undersigned from **27.02.2024** to **04.03.2024** (up to 1.00 P.M) during office hours on deposit of cost of tender document i.e. **Rs.2000/-** plus GST @ 18% amounting to **Rs.2360/-** in cash or in shape of A/c. payee demand draft drawn in favour of **“Odisha Construction Corporation Limited” – Project Account** on any Nationalized Bank / Scheduled Bank payable at Bhubaneswar (non-refundable) and production of attested copies of the following documents and verification thereof by the undersigned. The tender document can also be obtained by the interested reputed manufacturers / traders by registered post/speed post/courier on sending the cost of tender document i.e. **Rs.2000/-** plus GST @ 18% and postage charges of **Rs.100/-** amounting to **Rs.2460/-** in shape of A/C. payee demand draft drawn in favour of **“Odisha Construction Corporation Limited” - Project Account** on any Nationalized Bank / Scheduled Bank payable at Bhubaneswar (non-refundable) and sending attested copies of the following documents and verification thereof by the undersigned.

Signature of the tenderer or his/their
power of attorney holder
with designation & seal.

Senior Manager (Mech.)-I
OCC Ltd, Central Workshop,
Rasulgarh, Bhubaneswar-751010

- a. Valid GST Registration Certificate.
 - b. PAN Card
 - c. The bidders have to submit copies of purchase orders, credentials, certificates etc. in support of supply of similar items of magnitude minimum amounting to 5.00 lakh in last 5 financial years (i.e. from financial year 2018-19 to 2022-23 including current financial year 2023-24).
 - d. Tenderer should submit valid manufacturer / trader registration certificate
 - e. Tenderer should submit format of Bid Security Declaration from Bidder in lieu of EMD.
- 6) The tender document can also be downloaded from our Website www.odishaconstruction.com or Govt. of Odisha website www.odishagov.nic.in to submit the tender (**Bidders are requested to visit our website regularly for any changes since it will not be published in news paper again**). However, the cost of tender document i.e. **Rs.2000/-** plus GST @ 18% amounting to **Rs.2360/-** in shape of A/C. payee demand draft, as stated above in favour of "Odisha Construction Corporation Limited" - Project Account on any Nationalized Bank/ Scheduled Bank payable at Bhubaneswar (non-refundable) along with attested photo copies of all above documents should be submitted, while submitting tender in Envelope-I, otherwise, the tender will be cancelled. OCCL will not be responsible for missing of any page while downloading.
- 7) The tenders will be received up to **3.30 PM** on **04.03.2024** and same will be opened in the office of the undersigned on the same day at **4.00 PM** in presence of the tenderers or their authorized representatives, if they so desire. If there will be a public holiday on the last date of sale of tender document and receipt & opening of the tenders as specified above, the tender document will be sold and tenders will be received & opened on the next working day at the same time and venue.
- 8) The undersigned will not be responsible for any kind of delay in receipt of tenders by the postal/courier authorities.
- 9) The **PRICE SCHEDULE BID & TECHNICAL BID** will be opened on **04.03.2024 at 4.00 PM**. Then the documents in the first envelope submitted by the tenderers will be scrutinized preliminarily on the spot. The second envelope of the valid eligible tenders after preliminary scrutiny of the documents in the first envelope will be opened on the same day immediately subject to fulfilling the requirements mentioned in the tender schedule.
- 10) The materials should be supplied in finished / fully machined conditions by successful tenderer / supplier as per required dia, length and quantity and should strictly conform to relevant standards of Bureau of Indian Standard (BIS) as mentioned in detailed specification and price schedule.
- 11) The original test certificate of materials from a Govt./Govt. approved testing laboratory will be provided by the successful tenderer/ supplier along with supply of materials. The manufacturer's test certificate will have to be also furnished by the successful tenderer/ supplier. The purchaser is having the option to test the materials in any laboratory at the cost of the supplier and if the materials are not found in accordance with the specifications and grade in relevant Indian Standards, the materials will be rejected.
- 12) The materials will be guaranteed by the supplier against any defect for a period of 18 months from the date of supply or 12 months from the date of use, whichever is earlier. Guarantee certificate in this regard will accompany with supply of materials. If any defect is found in the materials within the guarantee period, the same will have to be replaced free of cost by the supplier.

**Signature of the tenderer or his/their
power of attorney holder
with designation & seal.**

**Senior Manager (Mech.)-I
OCC Ltd, Central Workshop,
Rasulgarh, Bhubaneswar-751010**

- 13) The rate of materials should be quoted by the tenderer on unit basis only. The same should be supplied by the successful supplier as per required dia, length and quantity in numbers as mentioned in detail specification and Price Schedule.
- 14) The tenderer will quote their rates F.O.R. OCCL Store, Central Workshop, Rasulgarh, Bhubaneswar-10 (Odisha) indicating separately the basic price, packing, forwarding, transportation, transit insurance, handling charges, taxes, duties, levies etc. strictly in the specifications and price schedule format in original. All columns and lines of the specification and price schedule should be filled in properly without leaving any thing blank. The details and rates of duties, taxes etc. should be indicated clearly in the specification and price schedule.
- 15) The tenderer should quote appropriate taxes with the offer.
- 16) The rates and amounts should be quoted both in figures and words in the price schedule. Any correction or overwriting in the specification and price schedule should be duly certified by the tenderer or his power of attorney holder. In case of any mismatch in figures and words, the rates in words will be considered. In case of any mismatch in rates and amount, the rate will be considered.
- 17) 90% payment will be made within 30 days of receipt, verification and acceptance of the complete materials along with bill, test certificate, guarantee certificate and other documents. Balance 10% will be released after 18 months of supply or 12 months from the date of commissioning whichever is earlier. However if a performance bank guarantee is received for 10% of the value of materials, the same will be released within 60 days from the date of receipt of materials.
- 18) The purchaser reserves the right to forfeit and encash the performance bank guarantee / EMD in full in case any casting is found defective and not replaced by the tenderer/supplier within a suitable time fixed by the corporation. Any repair to the casting shall be made only after approval of the purchaser. In this connection, the decision of the purchaser is final and binding on the tenderer/supplier.
- 19) Price escalation will not be allowed under any circumstances. The quoted rates will remain firm till execution of the work order.
- 20) The validity of the offer should be for a period of 120 (One hundred twenty) days from the date of opening of the tender.
- 21) The complete ordered quantity shall be supplied by the successful tenderer within 60 (Sixty) days from the date of issue of purchase order failing which the order is liable for cancellation without assigning any reason thereof by the purchaser. In case of cancellation of the order the EMD will be forfeited. In case of any delay in supply of material beyond the delivery schedule whatever may the reason, supplier shall be liable to pay L.D. @ 0.5% (Half percent) of the total order value per week of delay or part thereof subject to a maximum of 5% (Five percent) of the total order value.
- 22) Pre-delivery inspection (P.D.I) before despatch of the materials will be made at the manufacturer's works by the authorized representative of the purchaser / client / third party for which the manufacturer should intimate in writing for P.D.I. 10 days in advance regarding readiness for P.D.I.

**Signature of the tenderer or his/their
power of attorney holder
with designation & seal.**

**Senior Manager (Mech.)-I
OCC Ltd, Central Workshop,
Rasulgarh, Bhubaneswar-751010**

- 23) After submission of tender and before placing order, the bidder may be asked by the undersigned to attend techno-commercial discussions and reply to queries within a specified period. If the bidder fail to do so, the tender submitted by the bidder is liable to be cancelled.
- 24) Conditional offers with deviations will not be accepted. Those, who do not agree to the terms and conditions regarding payments, delivery and others, need not quote.
- 25) The authority reserves the right to accept/reject any or all tenders without assigning any reason thereof. The required quantity of materials can be splitted among the two or more tenderers. In this connection, the decision of purchaser is final and binding on the tenderer.
- 26) The duplicate copy of the order shall be signed by the supplier on each page with his seal as acceptance of the order and shall be returned to the purchaser within 07 (Seven) days of receipt of this order failing which the order is liable for cancellation.
- 27) Tender through fax/telex/telegram/e-mail will not be accepted.
- 28) Any dispute arising out of this tender or order thereof is to be settled in proper court under the jurisdiction of Odisha High Court at Cuttack or courts under the jurisdiction of Odisha High Court at Bhubaneswar only.

**Signature of the tenderer or his/their
power of attorney holder
with designation & seal.**

**Senior Manager (Mech.)-I
OCC Ltd, Central Workshop,
Rasulgarh, Bhubaneswar-751010**

ODISHA CONSTRUCTION CORPORATION LIMITED
(A GOVT. OF ODISHA UNDERTAKING)
CENTRAL WORKSHOP, RASULGARH,
BHUBANESWAR-751010 (ODISHA).

DETAILED SPECIFICATION AND PRICE SCHEDULE FOR
“SUPPLY OF CASTING ITEMS FOR VARIOUS GATE WORKS PROJECT”

VIDE TCN No.OCC/CWS/PROC/ KBP-02(P-I) / 72 /2023-24 DATED.26.02.2024 DUE DATE OF OPENING ON DATED 04.03.2024

Sl. No.	Description of Item	Part No	Unit	Qty. Reqd. in unit	Rate per unit in Rs.					Total amount in Rs. for full materials	
					Basic Price per unit	Packing, forwarding, transportation, transit insurance, handling charges, incidental charges etc.	GST as applicable	Total in figures	Total in words	In figure	In words
22T ROPE DRUM HOIST FOR KUSUMI BARRAGE PROJECT.											
1	SHEET 170 X 3.15 - 40 WIDTH SS04 Cr18Ni10	8-10	NOS	2							
2	SPROCKET (SP2)CONNECTED TO WORM GEAR 20T STR.STEEL - AS PER DRAWING IN ANNEXURE-I	8-16	NOS	2							
3	SPROCKET (SP1)CONNECTED TO P1W2 SHAFT 19T STR.STEEL - AS PER DRAWING IN ANNEXURE - II	8-17	NOS	2							
4	Ø400 - 6 TH. DIAL PLATE- BRASS OF IS:410 AS PER DRAWING IN ANNEXURE - III	8-21	NOS	2							
5	DOG CLUTCH (SLIDING)- STR.STEEL - AS PER DRAWING - IV	9-4	NOS	2							
6	DOG CLUTCH (FIXED)- STR.STEEL AS PER DRAWING IN ANNEXURE - IV	9-5	NOS	2							
7	SLIDER BUSH- BRASS AS PER DRAWING IN ANNEXURE - V	9-6	NOS	4							

Signature of the tenderer or his/their
power of attorney holder
with designation & seal.

Senior Manager (Mech.)-I
OCC Ltd, Central Workshop,
Rasulgarh, Bhubaneswar-751010

8	CHAIN SPROCKET (DRIVEN)- STR.STEEL - AS PER DRAWING IN ANNEXURE – VI	9-13	NOS	2							
9	CHAIN WHEEL (DRIVING)-STR.STEEL AS PER DRAWING IN ANNEXURE – VII	9-14	NOS	2							
10	Ø50MM PULLY WITH PIN SUITABLE FOR Ø4MM WIRE ROPE STD.	10-11	NOS	4							
16T ROPE DRUM HOIST FOR KUSUMI BARRAGE PROJECT.											
11	SHEET 170 X 3.15 - 40 WIDTH SS04 Cr18Ni10	8-10	NOS	6							
12	SPROCKET (SP1)CONNECTED TO P1W2 SHAFT 20T STR.STEEL - AS PER DRAWING IN ANNEXURE – VIII	8-16	NOS	6							
13	SPROCKET (SP2)CONNECTED TO WORM GEAR 19T STR.STEEL - AS PER DRAWING IN ANNEXURE – IX	8-17	NOS	6							
14	Ø400 - 6 TH. DIAL PL. BRASS OF IS:410 – AS PER DRAWING IN ANNEXURE – X	8-21	NOS	6							
15	DOG CLUTCH (SLIDING)- STR.STEEL AS PER DRAWING IN ANNEXURE – XI	9-4	NOS	6							
16	DOG CLUTCH (FIXED)- STR.STEEL - AS PER DRAWING IN ANNEXURE - XI	9-5	NOS	6							
17	SLIDER BUSH BRASS-AS PER DRAWING IN ANNEXURE – XII	9-6	NOS	12							
18	CHAIN SPROCKET (DRIVEN) STR.STEEL -AS PER DRAWING IN ANNEXURE – XIII	9-13	NOS	6							
19	CHAIN WHEEL (DRIVING) STR.STEEL -AS PER DRAWING IN ANNEXURE – XIV	9-14	NOS	6							
20	Ø50 PULLY WITH PIN SUITABLE FOR Ø4 WIRE ROPE STD.	10-11	NOS	12							
LIFTING BEAM FOR BARRAGE BAY AND UNDERSLUICE GATE OF KUSUMI BARRAGE PROJECT.											
21	BUSH (FOR WHEEL) LTB-1 OF IS:318-1981 -AS PER DRAWING IN ANNEXURE – XV	2-11	NOS	4							
22	BUSH (FOR HOOK) ALUMINIUM BRONZE GR. AB-1 OF IS:305 -AS PER DRAWING IN ANNEXURE – XVI	3-3	NOS	2							
23	BUSH FOR OPERATING ARM LTB-1 OF IS:318 - AS PER DRAWING IN ANNEXURE - XVII	3-13	NOS	1							

**Signature of the tenderer or his/their
power of attorney holder
with designation & seal.**

Page-2

**Senior Manager (Mech.)-I
OCC Ltd, Central Workshop,
Rasulgarh, Bhubaneswar-751010**

HOIST SUPPORTING FOR 22T ROPE DRUM HOIST OF KUSUMI BARARGE PROJECT.											
24	BUSH GR.AB-2 OF IS:305 -AS PER DRAWING IN ANNEXURE - XVIII	4-4	NOS	4							
HOIST SUPPORTING FOR 16T ROPE DRUM HOIST OF KUSUMI BARRAGE PROJECT.											
25	BUSH Gr.AB-1 OF IS:305 -AS PER DRAWING IN ANNEXURE - XIX	4-4	NOS	12							
STOPLOGS FOR BARRAGE BAY GATE OF BARRAGE(1SS) ACROSS RIVER BAITARANI LEFT ARM NEAR JAJPUR TOWN AT SAPTAMATRUKA TEMPLE (LEFT ARM)											
26	230 X 100 X 20 TH.PL. (BRONZE PAD) LTB-1 OF IS:318 AS PER DRAWING IN ANNEXURE - XX	3-19	NOS	12							
HOIST SUPPORTING STRUCTURE FOR SAPTAMATRUKA BARRAGE PROJECT(LEFT ARM)											
27	BRONZE BUSH Gr.AB-2 OF IS:305 -AS PER DRAWING IN ANNEXURE - XXI	4-4	NOS	16							

Signature of the tenderer or his/their
power of attorney holder
with designation & seal.

Page-3

Senior Manager (Mech.)-I
OCC Ltd, Central Workshop,
Rasulgarh, Bhubaneswar-751010

Annexure - I

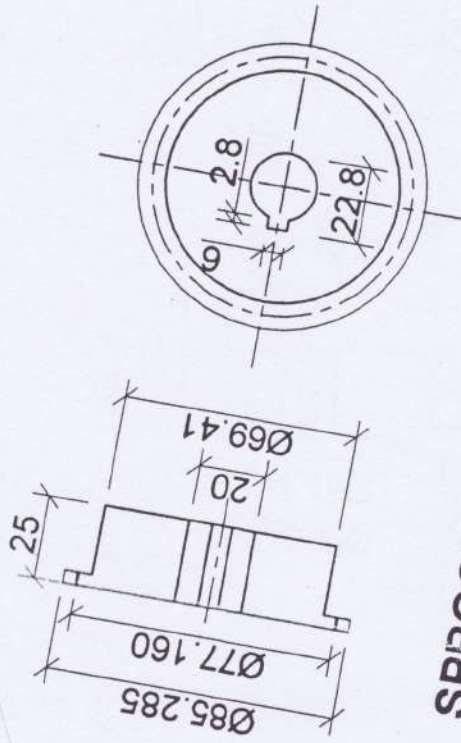

SPROCKET DETAIL - (8-16)

TOTAL QTY. REQD. = 02 (TWO) NOS.

22 T ROPE DRUM HOIST OF
KUSUMI BARRAGE PROJECT. OCCL

Annexure - II

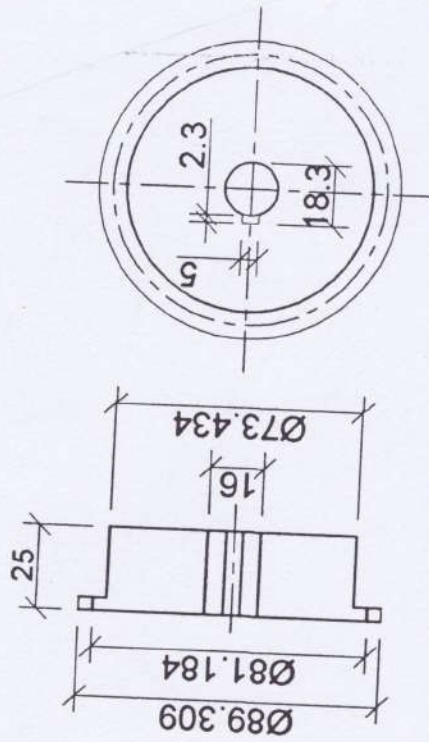

SPROCKET DETAIL - (8-17)

TOTAL QTY. REQD. = 02 (TWO) NOS.

22T ROPE DRUM HOIST OF
KUSUMI BARRAGE PROJECT. OCCL

Annexure - III

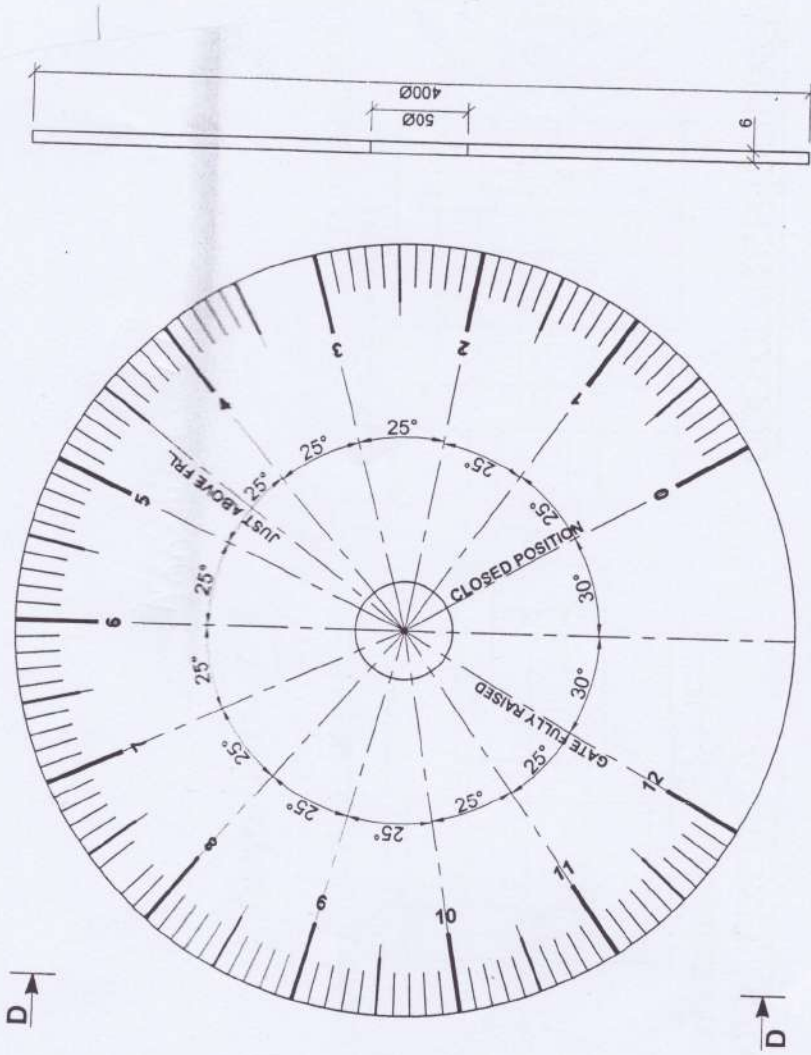

VIEW - DD

DIAL (8-21)

MARKING ARE TO BE ENGRAVED

TOTAL QTY REQD. = 02 NOS. (TWO) NOS.

22 T ROPE DRUM HOIST OF KUSUMI
BARRAGE PROJECT - OCCL

Annexure - IV

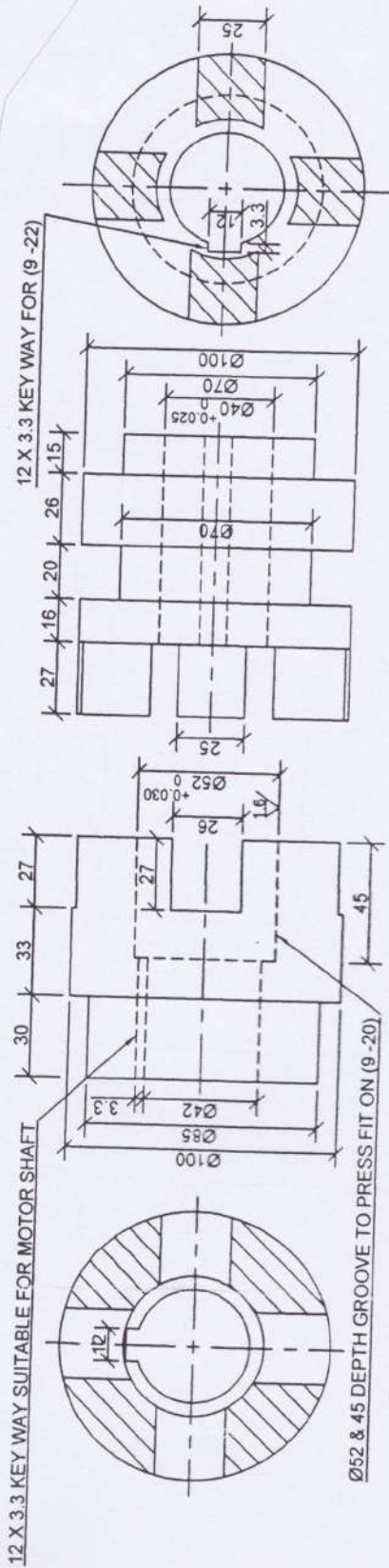

DOG CLUTCH (FIXED) (9-5)

TOTAL QTY REQD. = 02 (TWO) NOS.

Note: - (9-22) - Parallel key A12 X 8 X 220 long of IS: 2048.

DOG CLUTCH (SLIDING) (9-4)

TOTAL QTY. REQD. = 02 (TWO) NOS.

22T ROPE DRUM HOIST OF KUSUMI BARRAGE PROJECT. OCCL.

Amekure-2

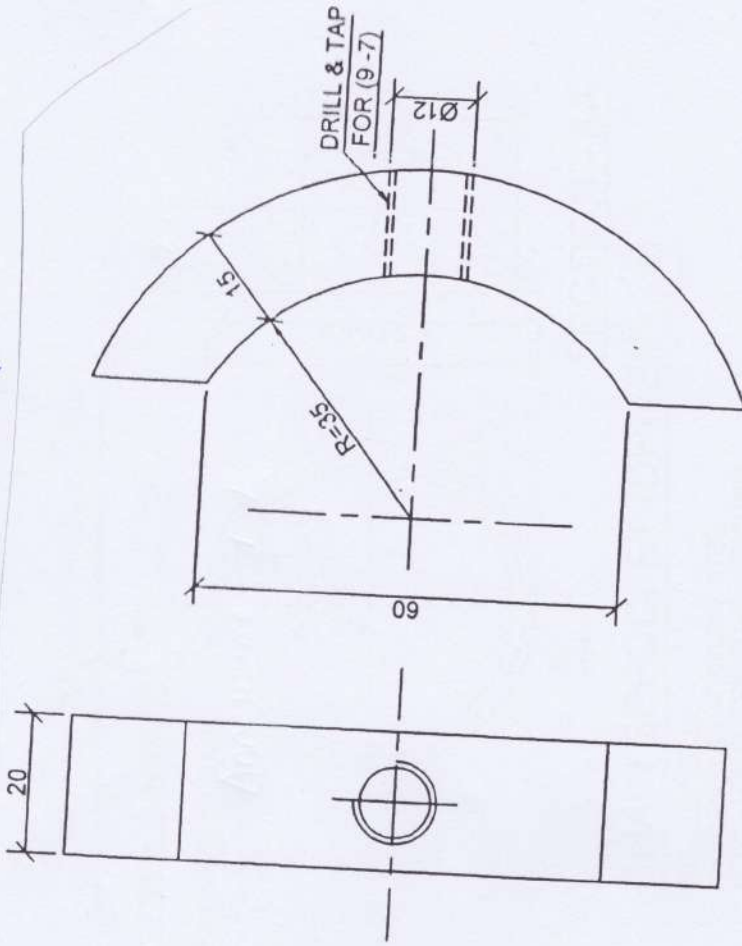

SLIDER BUSH (9-6)
MATERIAL - BRASS

TOTAL QTY REQD. = 04 (FOUR) NOS.

Note:- (9-7) - Pin for slider bush.

22T ROPE DRUM HOIST OF
KUSUMI BARRAGE PROJECT. OCCL

Annexure - 2

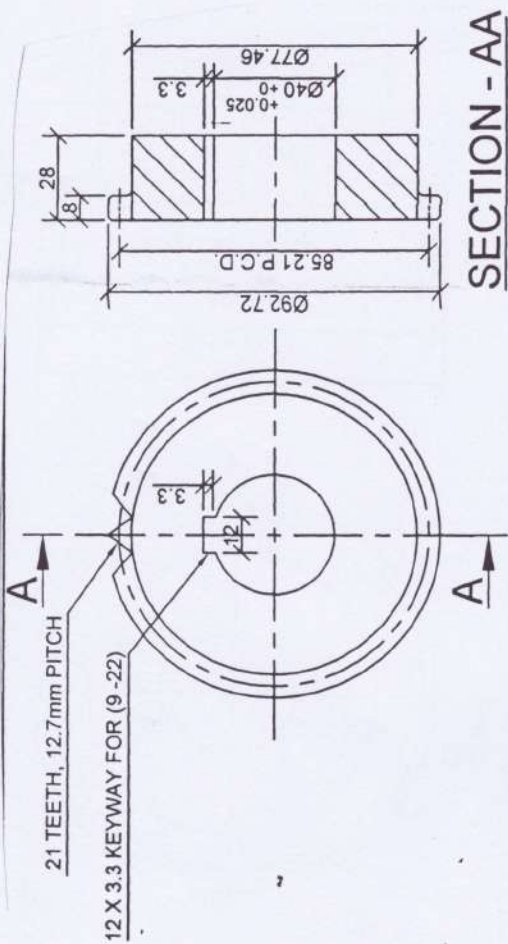

CHAIN SPROCKET (DRIVEN) (9-13)

SPECIFICATION :-
MATERIAL - CAST STEEL/STR STEEL
PITCH - 12.7 FOR CHAIN 082-1 OF IS.2403
NOS. OF TEETH = 21

TOTAL QTY REQD. = 02 (TWO) NOS.

Note :- (9-22) - Parallel key A12 X 8 X 220 long of IS: 2048

22T ROPE DRUM HOIST OF
KUSUMI BARRAGE PROJECT. OCCL

Annealed - CVII

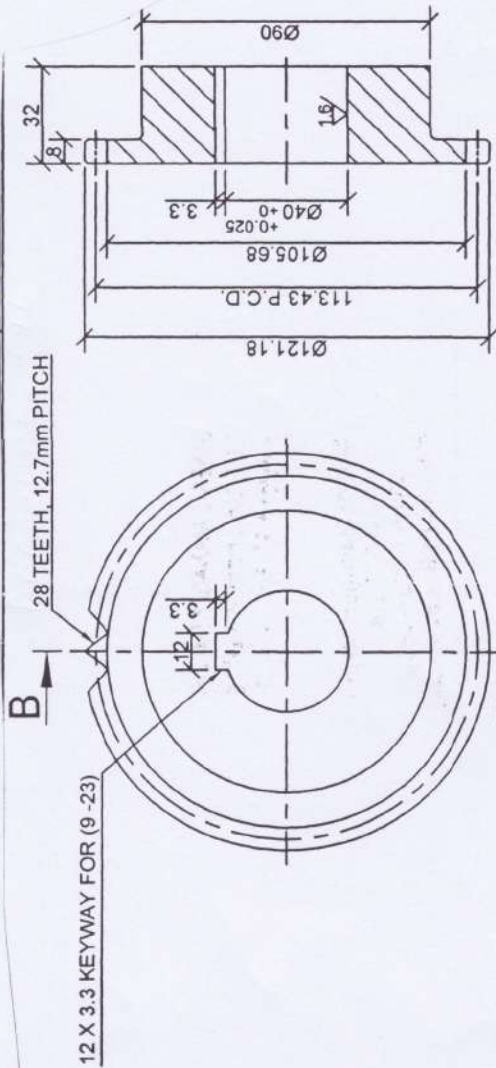

CHAIN WHEEL (DRIVING) (9-14)

SECTION - BB

SPECIFICATION :-
MATERIAL - CAST STEEL/STR. STEEL
PITCH - 12.7 FOR CHAIN 082-1 OF IS:2403
NOS. OF TEETH = 28

TOTAL QTY REQD. = 02 (TWO) NOS.

Note :- (9-23) - Parallel key A12 X 8 X 32 long of IS: 2048

22T ROPE DRUM MOIST OF
KUSUMI BARRAGE PROJECT.

OCCL

Annexure - VII

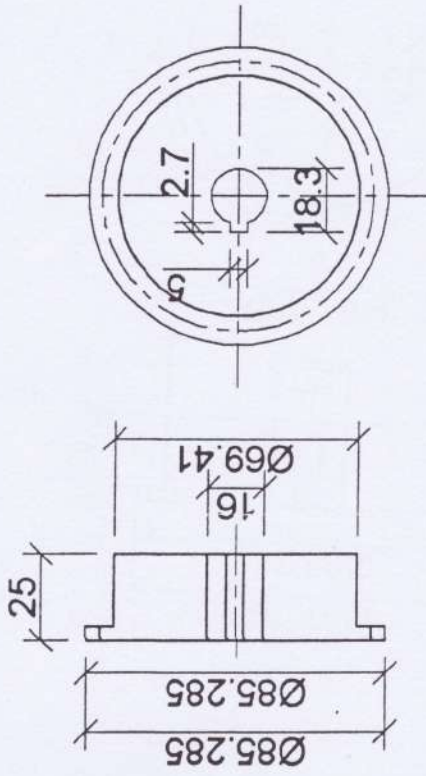

SPROCKET DETAIL - (8-16)

TOTAL QTY REQD. = 06 (SIX) NOS.

16T ROPE DRUM HOIST OF
KUSOMI BARRAGE PROJECT.
OCCL.

Annexure - IX

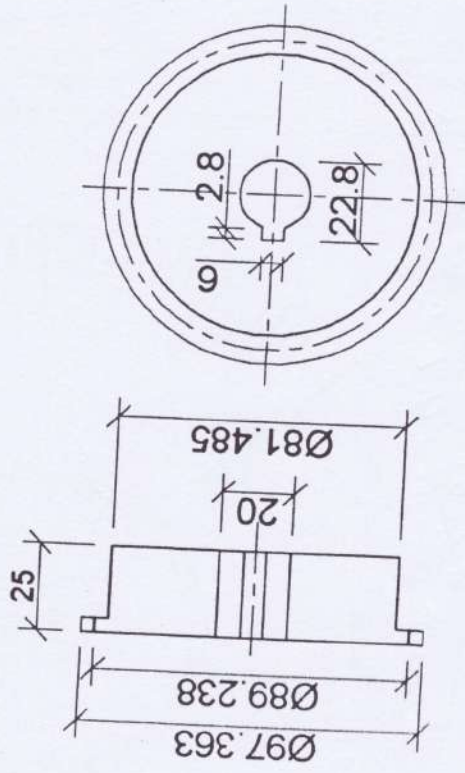

SPROCKET DETAIL - (8-17)

TOTAL QTY REQD. = 06 (SIX) NOS.

16T ROPE DRUM HOIST OF
KUSOMI BARRAGE PROJECT.
OCCL.

Annexure-X

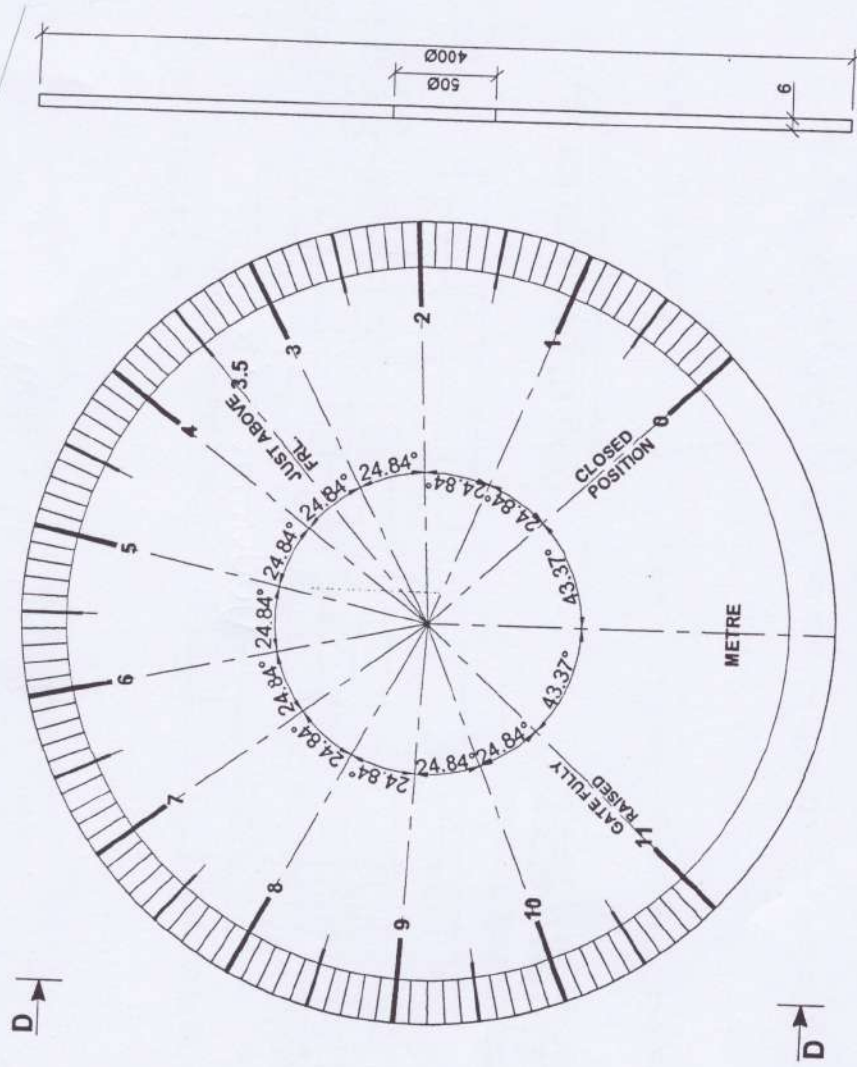

VIEW - DD

DIAL (8-21)
MARKING ARE TO BE ENGRAVED

TOTAL QTY REQD. = 06 (SIX) NOS

16T ROPE FROM HOIST OF KUSUMI
BARRAGE PROJECT. OCCL

Annexure - XI

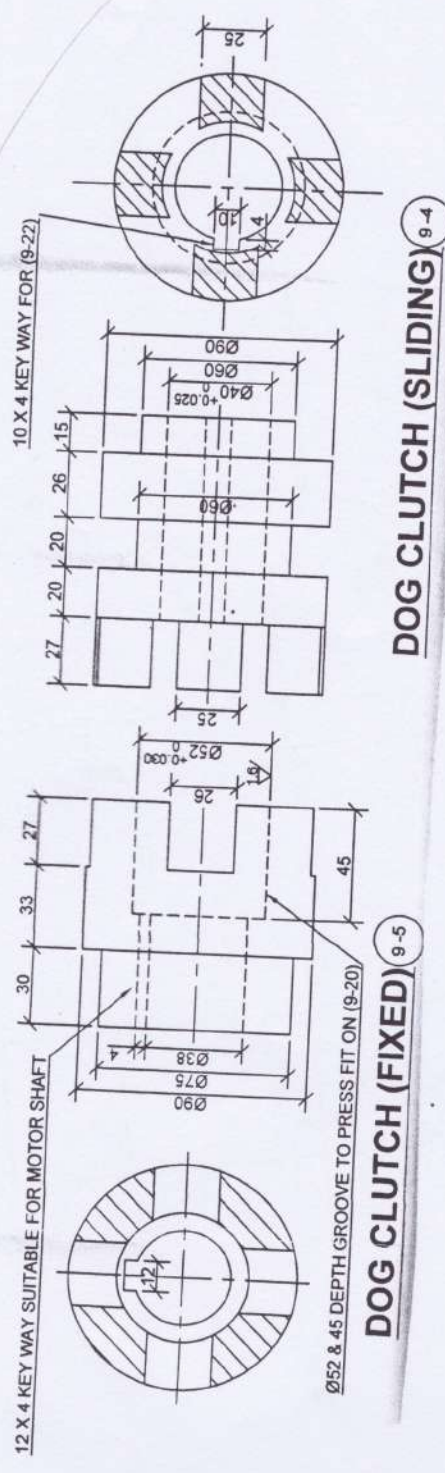

TOTAL QTY. REQD = 06 (SIX) NOS.

TOTAL QTY. REQD. = 06 (SIX) NOS.

Note:- (9-22) - 10x10 - 220 long square key.

16T ROPE DRUM HOIST OF KUSUMI
BARRAGE PROJECT. OCCL.

Appendure - XII

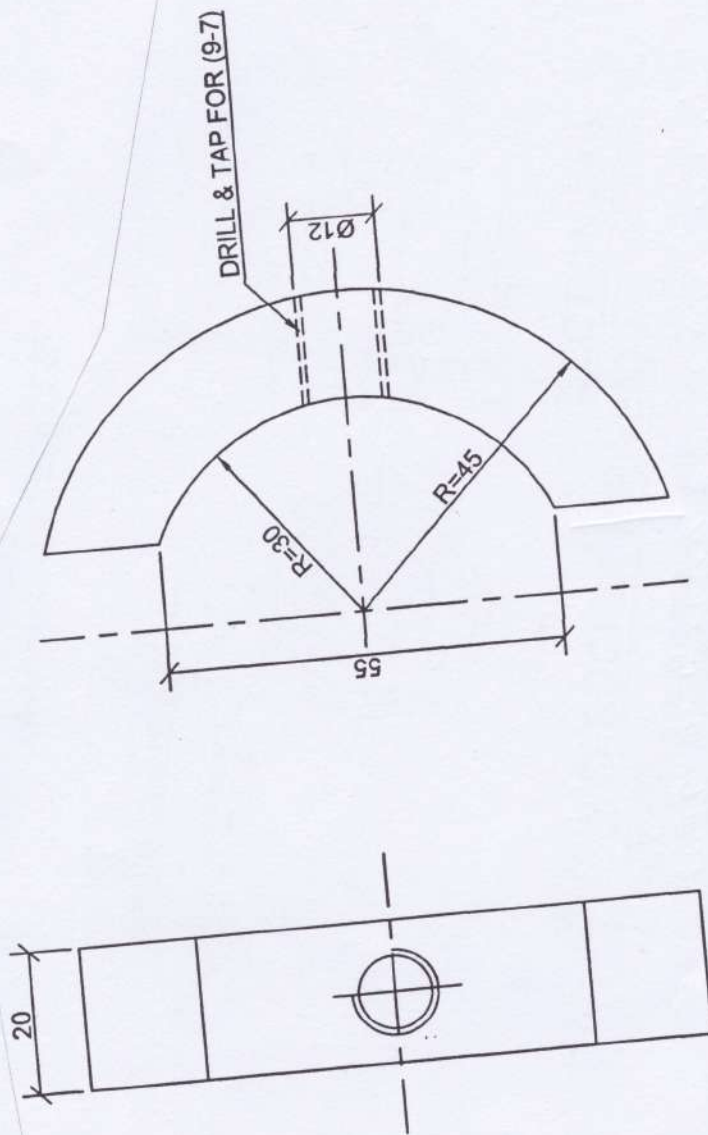

SLIDER BUSH 9-6

MATERIAL:- BRASS

TOTAL QTY REQD. = 12 (TWELVE) NOS.

16T ROPE DRUM HOIST OF KUSOMI
BARRAGE PROJECT. OCCL.

Annexure - XIII

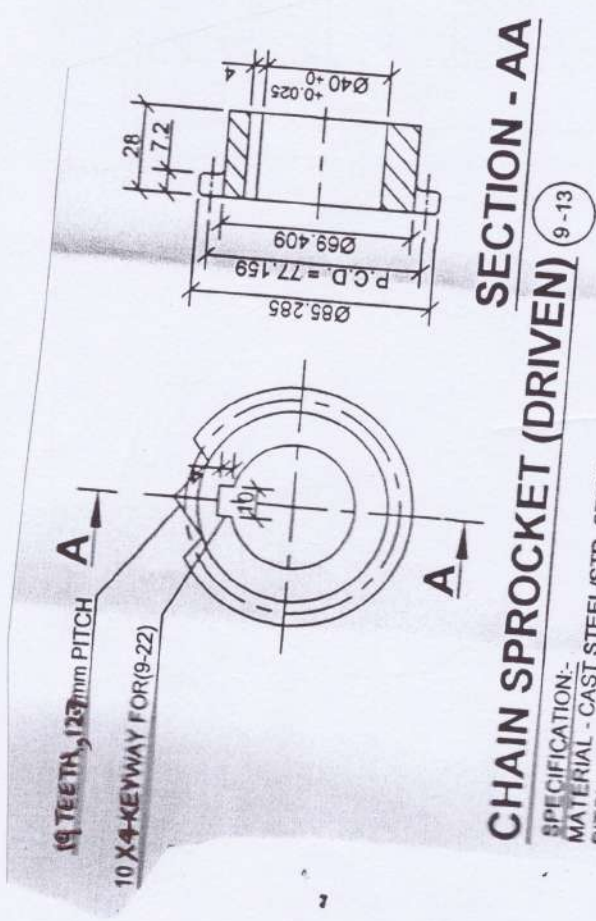

CHAIN SPROCKET (DRIVEN) 9-13

SPECIFICATION:-
MATERIAL - CAST STEEL/STR. STEEL
PITCH - 12.7 FOR CHAIN 084-1 IS:2403
NOS. OF TEETH - 19

TOTAL QTY REQD. = 06 (SIX) NOS.
Note :- (9-22) - 10 X 10 - 220 long square key

16T ROPE DRUM HOIST OF KUSOMI
BARRAGE PROJECT. OCCL.

Annexure - 22v

Note: - (9-23) - (10x10) - 32 long square key

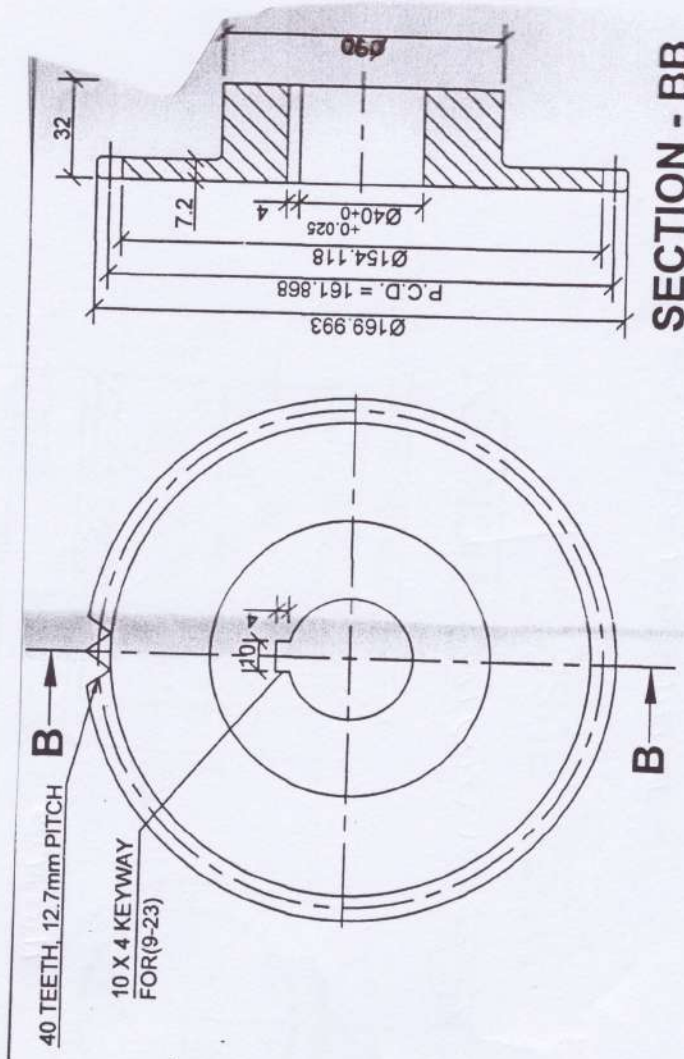

CHAIN WHEEL (DRIVING) 9-14

SPECIFICATION:-
MATERIAL - CAST STEEL/STR. STEEL
PITCH - 12.7 FOR CHAIN 084-1 IS:2403
NOS. OF TEETH - 40

TOTAL QTY REQD. = 06 (SIX) NOS.

16T ROPE DRUM HOIST OF
KUSUMI BARRAGE PROJECT,
OCCL.

Appendix - XXV

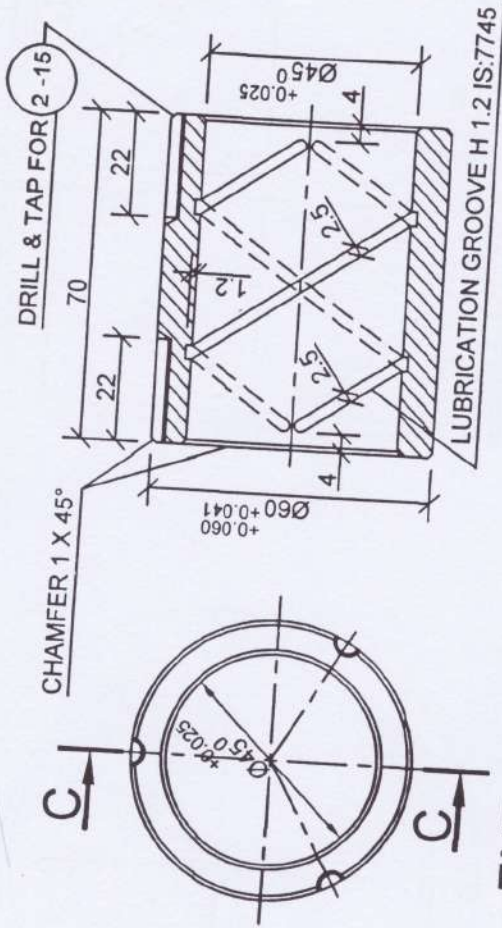

END VIEW

SECTION - CC

WHEEL BUSH (2-11)

MATL. :- LTB - 1 OF IS:318

TOTAL QTY. REQD. = 04 (FOUR) NOS.

Note:- (2-15) - Gsub screw CM6 X 2.0 IS: 2388 - 6.6

LIFTING BEAM OF STOPLOG OF
KUSUMI BARRAGE PROJECT.
OCC.

Annexure - 201

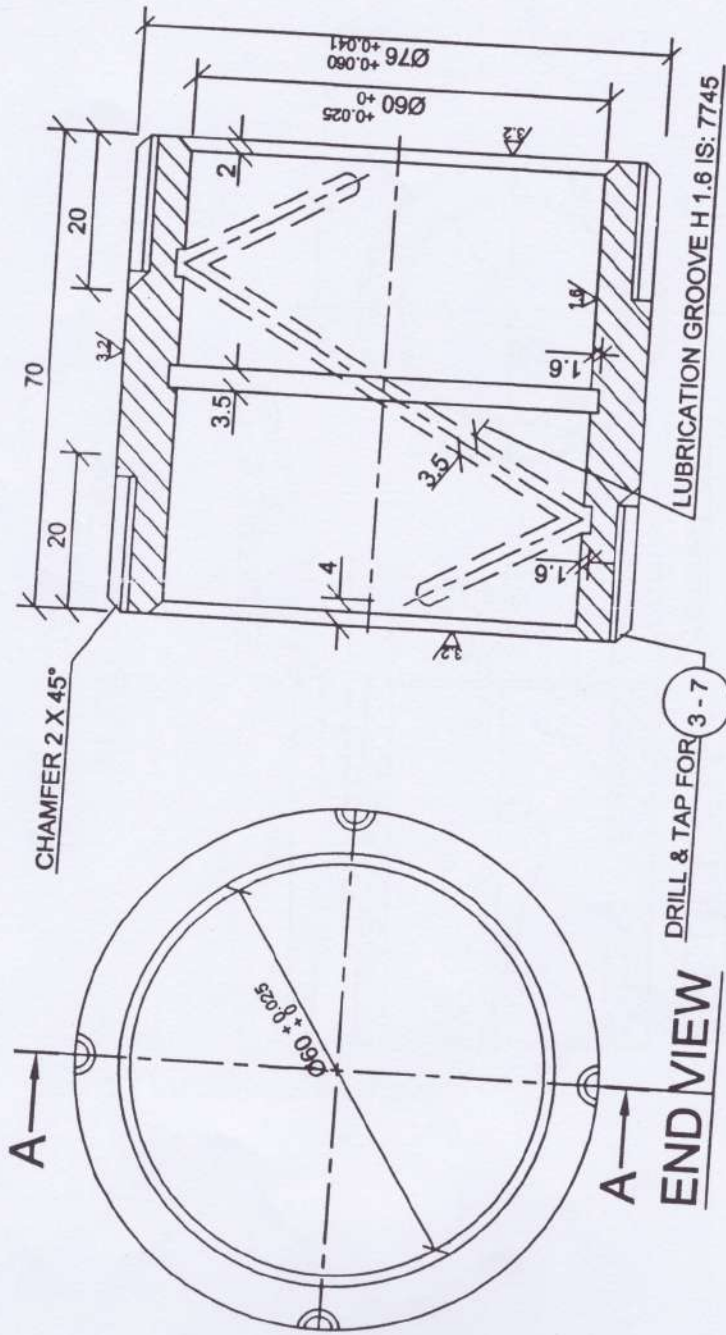

BUSH (3-3) (FOR HOOK)

MATERIAL - ALUMINIUM BRONZE GR. AB-1 OF IS:305

TOTAL QTY REQD = 02 (TWO) NOS.

Note:- (3-7) - Grab screw CM 6 X 20 IS: 6094 - 10.9

LIFTING BEAM OF STOPLOG OF
KUSUMI BARRAGE PROJECT.
OCCU

LUBRICATION GROOVE H 1.2 IS: 7745

Annexure - DRILL

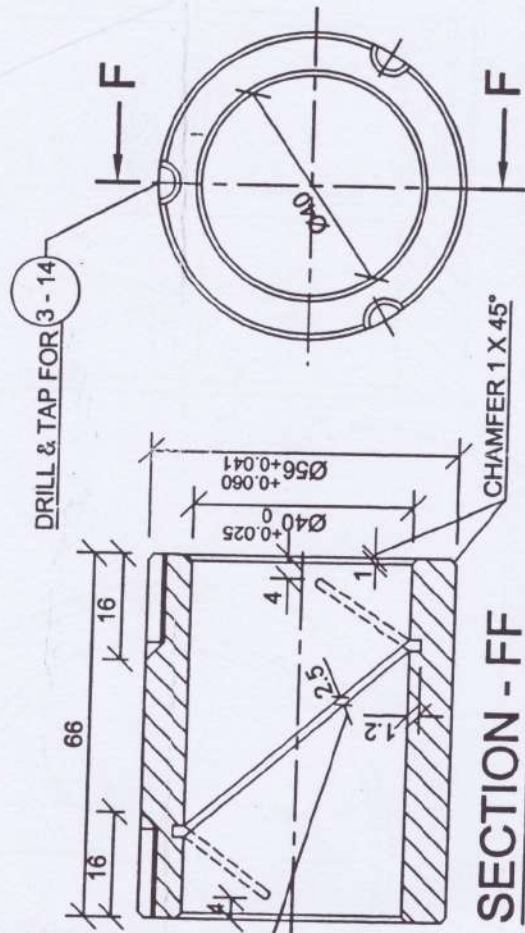

SECTION - FF

END VIEW

BUSH (3-13) (FOR OPERATING ARM)

MATERIAL - LTB-1 OF IS:318

TOTAL QTY. REQD. = 01 (ONE) NOS.

Note :- (3-14) - Grob basew CM 6X16 IS: 6094-10.9

LIFTING BEAM OF STOPLOG OF
KUSUMI BARRAGE PROJECT.
OCCL.

Annexure - XIII

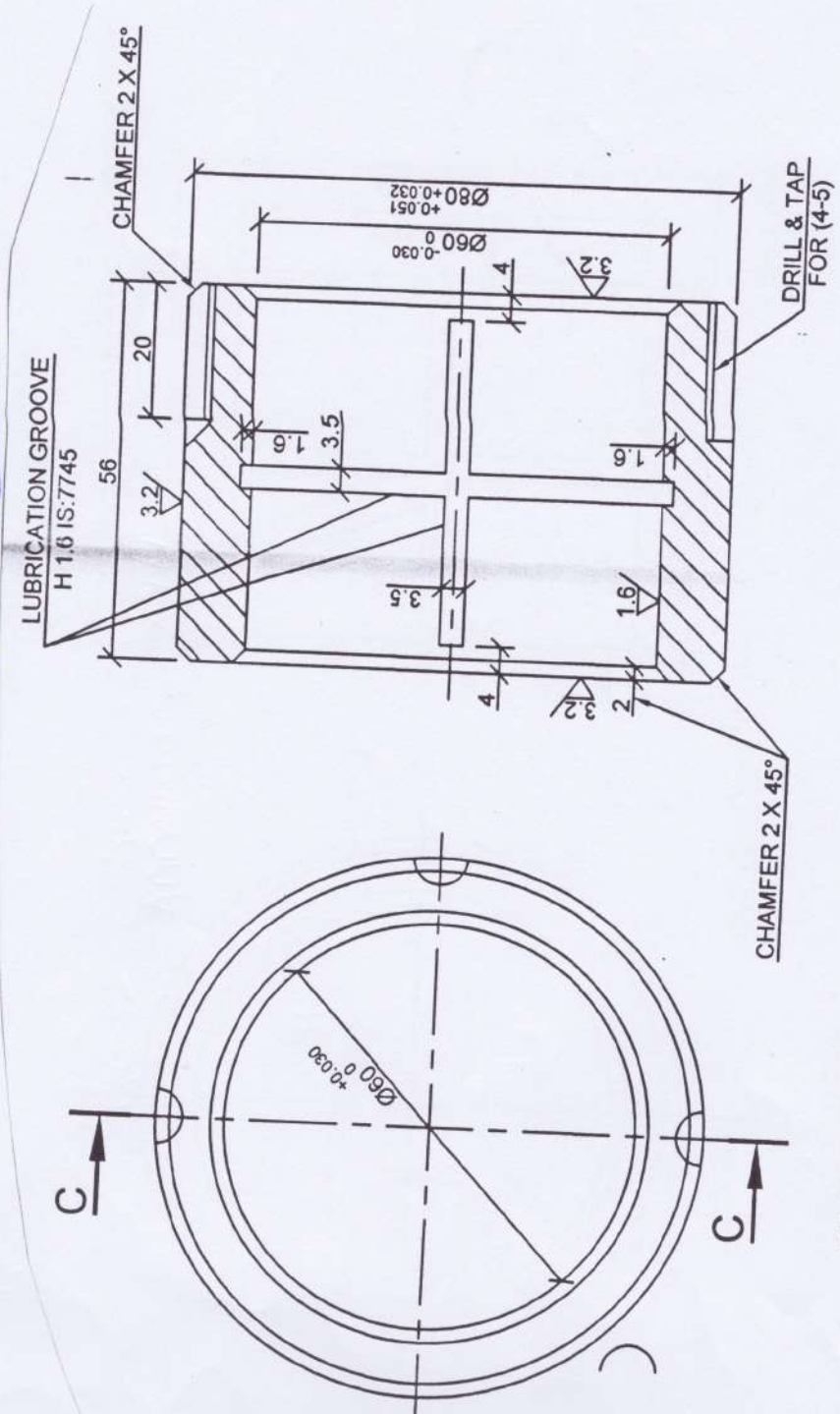

END VIEW

BUSH 4-4

SECTION - CC

MATERIAL-Gr.AB-2 OF IS:305

TOTAL QTY REQD. = 04 (FOUR) NOS.

Note:- (4-5) - Grub screw M8 X 16 IS: 2388 - 6.6

HOIST SUPPORTING STRUCTURE FOR 22T
ROPE DRUM HOIST OF KUSUMI BARRAGE
PROJECT. OCCL

Appendix - 277

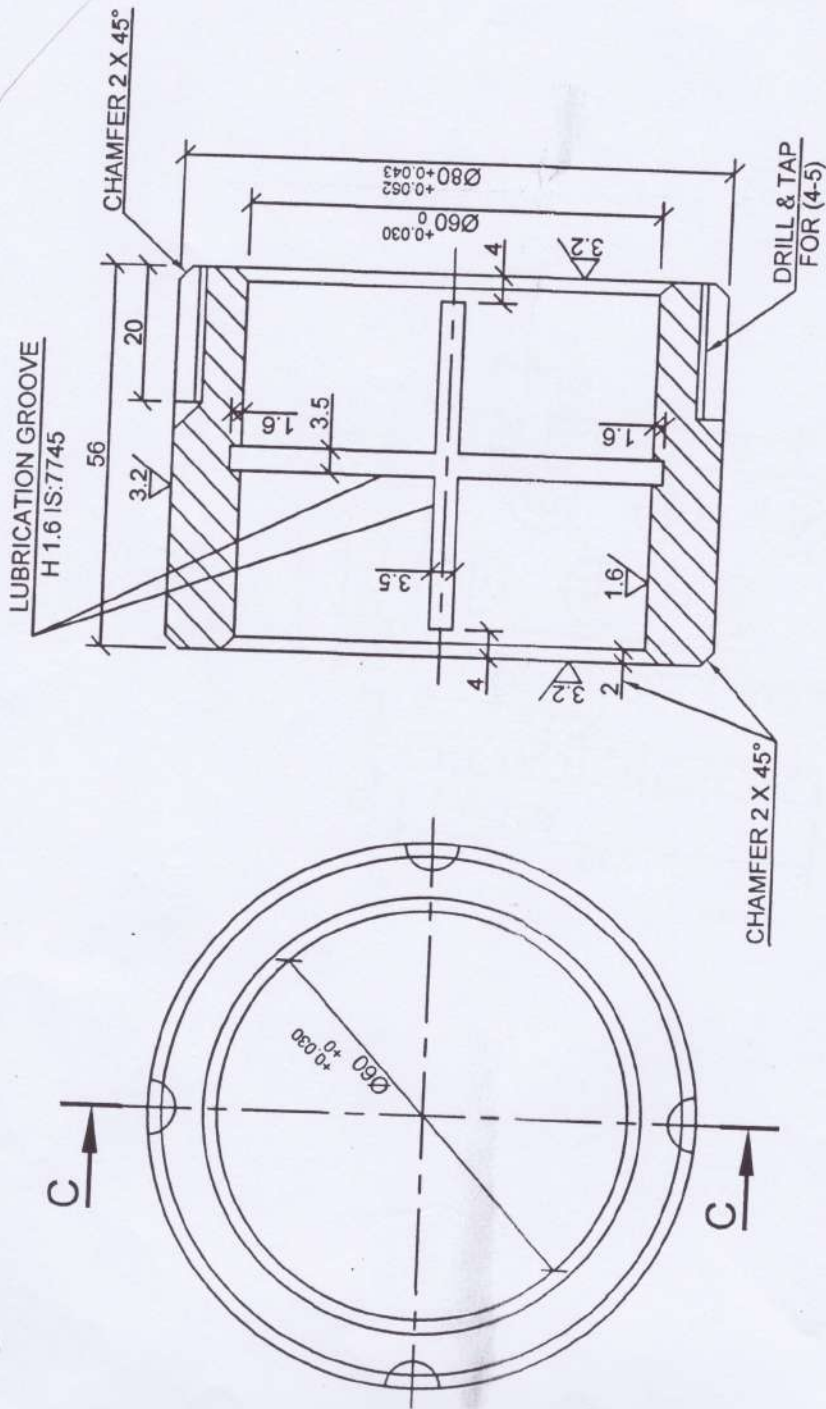

END VIEW

SECTION - CC

BUSH (4-4)

MATERIAL-Gr. AB-1 OF IS:305

TOTAL QTY REQD. = 12 (TWELVE) NOS.

Note :- (4-5) - Grub screw CM 8 X 16 IS: 2388 - 6.6

HOIST SUPPORTING STRUCTURE FOR
16T ROPE DRUM HOIST OF KUSUMI

Annexure - XX

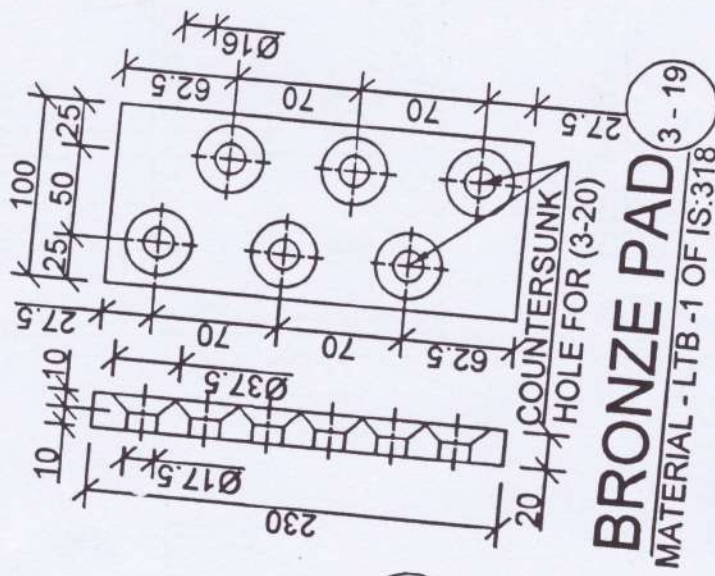

TOTAL QTY REQD. = 12 (TWELVE) NOS.
 Note :- (3-20) - counter sunk screws M16 X 45 IS:1365
 STOPLOG FOR BARRAGE BAY GATES OF
 SAPTAMATRUKA BARRAGE PROJECT. LEFT
 ARM.

Annexure - 7 XI

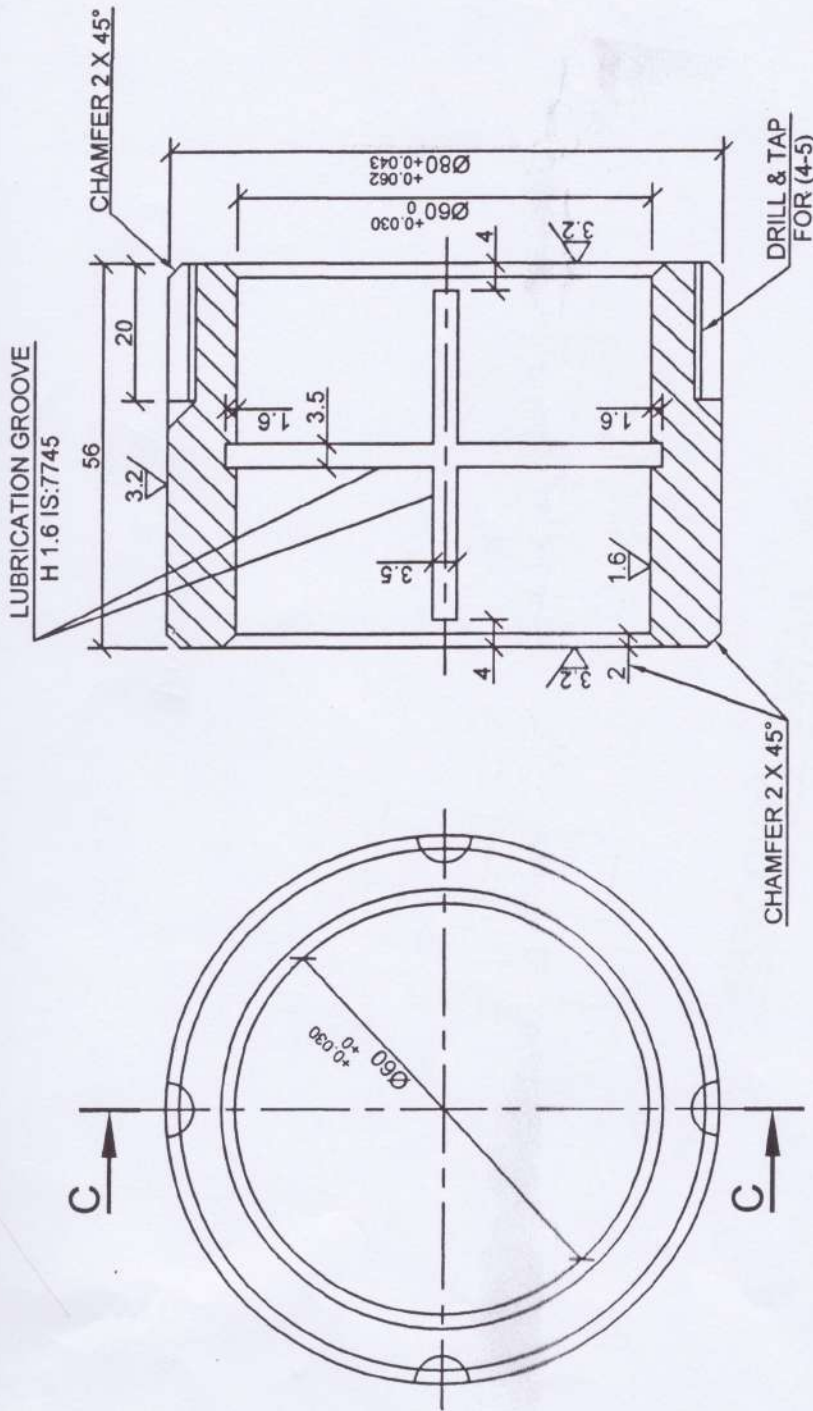

END VIEW

SECTION - CC

BUSH (4-4)

MATERIAL-Gr.AB-2 OF IS:305

TOTAL QTY REQD. = 16 (SIXTEEN) NOS.

Note :- (4-5) - Gumbo screw CM 8 X 16 IS: 2388 - 6.6
HOIST SUPPORTING STRUCTURE FOR IHT
ROPE DRUM HOIST OF SAPTA MATRUKA
BARRAGE PROJECT. [LEFT ARM].