

**ODISHA CONSTRUCTION CORPORATION LIMITED**  
(A GOVT. OF ODISHA UNDERTAKING)  
**CENTRAL WORKSHOP, RASULGARH,**  
**BHUBANESWAR-751010 (ODISHA)**

\* \* \* \* \*

**TENDER DOCUMENT FOR**  
**“SUPPLY OF CASTING ITEMS FOR SAPTAMATRUKA BARRAGE PROJECT( RIGHT ARM &**  
**LEFT ARM) ”**

The tender document comprises of the following:

1)	Tender call notice No. OCC/CWS/PROC/ SMP-10/ 45 /2023-24 dated.09.11.2023	01 (One) sheet
2)	Terms and conditions	04 (Four) sheets
3)	Drawings	22 (Fourteen) sheets
4)	Price schedule	03 (Three) sheet
----- Total :		30 (Thirty) sheets -----

**Signature of the tenderer or his/their  
power of attorney holder  
with designation & seal.**

**Senior Manager (Mech.)-I  
OCC Ltd, Central Workshop,  
Rasulgarh, Bhubaneswar-751010**

**ODISHA CONSTRUCTION CORPORATION LIMITED**  
(A GOVT. OF ODISHA UNDERTAKING)  
**CENTRAL WORKSHOP, RASULGARH,**  
**BHUBANESWAR-751010 (ODISHA)**

**TENDER CALL NOTICE No. OCC/CWS/PROC/ SMP-10 / 45 /2023-24 dated. 09.11.2023**

Sealed tenders in conformity with the terms, conditions, drawing and technical specifications in tender documents are invited from reputed manufacturers / traders for “Supply of casting items for Saptamatruka Barrage Project (Right arm and Left Arm)” as per details below:

Cost of tender document (Non-refundable)	Sale of tender document		Earnest money deposit (EMD) required	Receipt of tender	Opening of Technical & price bid of tender
<b>Rs. 2000/-</b> GST @ 18% <b>Rs.2360/-</b> by hand & <b>Rs.2460/-</b> by Regd. Post/ courier	From <b>09.11.2023</b>	To <b>20.11.2023</b> up to <b>1.00 PM</b>	1(One)% of the total quoted value including GST	Up to <b>3.30 P.M.</b> on <b>20.11.2023</b>	At <b>4.00 PM</b> on <b>20.11.2023</b>

The tender document can be purchased by the interested reputed manufacturers or their authorized dealers / traders by hand from the office of the undersigned on deposit of cost of tender document i.e. **Rs.2000/-** plus GST @ 18% amounting to **Rs.2360/-** in cash or in shape of A/c. payee demand draft drawn in favour of “Odisha Construction Corporation Limited” - Project Account on any Nationalised Bank/ Scheduled Bank payable at Bhubaneswar (Non-refundable) and production of attested copies of the following documents and verification thereof by the undersigned. The tender document can also be obtained by the interested reputed manufacturers or their authorized dealers / traders by registered post, speed post/ courier on sending the cost of tender document i.e. **Rs.2000/-** plus GST @ 18% and postage charges of **Rs.100/-** amounting to **Rs.2460/-** in shape of A/c. payee demand draft drawn as stated above and attested copies of the following documents and verification thereof by the undersigned. The undersigned will not be responsible for any kind of delay by the postal/courier authorities.

- 1) Valid GST Registration Certificate.
- 2) PAN Card
- 3) The bidders have to submit copies of purchase orders, credentials, certificates etc. in support of supply of similar items of magnitude minimum amounting to 5.00 lakh in last 5 financial years (i.e. from financial year 2018-19 to 2022-23 including current financial year 2023-24).
- 4) Tenderer should submit valid manufacturer / trader registration certificate.

The tender document can also be downloaded from our Website [www.odishaconstruction.com](http://www.odishaconstruction.com) or Govt. of Odisha website [www.odishagov.nic.in](http://www.odishagov.nic.in) to submit the tender (**Bidders are requested to visit our website regularly for any changes**). However, the cost of tender document i.e **Rs.2000/-** plus GST @ 18% amounting to **Rs.2360/-** in shape of A/c payee demand draft as stated above in favour of “Odisha Construction Corporation Limited” - Project Account on any Nationalised Bank/ Scheduled Bank payable at Bhubaneswar (Non-refundable) along with attested photo copies of all above documents should be submitted while submitting the tender in Envelope-I. Otherwise, the offer shall not be considered and OCCCL will not be responsible for missing of any page while downloading. If there will be a public holiday on the last date of sale of tender document and receipt & opening of the tender as specified above, the tender document will be sold and tender will be received & opened on the next working day at the same time and venue.

**The SSI/NSIC/MSME units participating in tender are not entitled for exemption from payment of EMD / Tender Paper costs as communicated vide DOWR Letter No. IIM-24/2018-14318/WR dated 24.05.2018 & Head Office, OCCL Letter No.5502/OCC/ CW-02/09(Vol-V)(WE) dated 30.05.2018.**

The tenders will be opened in the presence of the tenderers or their authorised representatives. Tender through Fax/Telex/telegram/e-mail will not be accepted

The undersigned reserves the right to accept or reject any or all quotations without assigning any reason thereof

Signature of the tenderer or his/their  
power of attorney holder  
with designation & seal.

Senior Manager (Mech.)-I  
OCC Ltd, Central Workshop,  
Rasulgarh, Bhubaneswar-751010

**ODISHA CONSTRUCTION CORPORATION LIMITED**  
(A GOVT. OF ODISHA UNDERTAKING)  
**CENTRAL WORKSHOP, RASULGARH,**  
**BHUBANESWAR-751010 (ODISHA)**

**TERMS AND CONDITIONS OF TENDER FOR**  
**“SUPPLY OF CASTING ITEMS FOR SAPTAMATRUKA BARRAGE PROJECT( RIGHT ARM &**  
**LEFT ARM)”**

- 1) Reputed manufacturers/ traders having supplied similar item of similar magnitude earlier and satisfactorily accepted by the clients will be eligible to participate in the tender. The copies of purchase orders, credentials, certificates etc. in support of similar supply and satisfactory performance thereof will be furnished along with the tender.
- 2) Tender should be submitted in two bid system in two separate sealed covers and both will be submitted in a single sealed outer cover subscribing in bold letters as **“Supply of casting items for Saptamatruka Barrage Project (Right arm and Left Arm)”** and also date of opening of tender. The name and address of the tenderer should not be written on outer cover. Only the name and address of the purchaser should be written on the outer cover.
- 3) The tenderer should submit Earnest Money Deposit (EMD) @ 1(One)% of the total quoted value along with the tender in shape of A/C payee Demand Draft drawn in favour of “Odisha Construction Corporation Limited” - Project Account on any Nationalised Bank / Scheduled bank payable at Bhubaneswar. The tenders received without EMD will be out rightly rejected. EMD of the unsuccessful tenderers will be released only after finalization of the tender.
- 4) i) The first envelope super scribing in bold letters as **“TECHNICAL BID”** should contain the following:
  - a. EMD of 1% as per clause- 3 above.
  - b. Attested copy of valid GST registration certificates. The tenderer will mention his GST Regn. No. in his tender clearly without which the tender will not be taken into consideration.
  - c. Attested copy of PAN Card.
  - d. The bidders have to submit copies of purchase orders, credentials, certificates etc. in support of supply of similar items of magnitude minimum amounting to 05.00 lakh in last 5 financial years (i.e. from financial year 2018-19 to 2022-23 including current financial year 2023-24).
  - e. Complete tender document in original including terms and conditions but without detailed specifications and price schedule duly signed on each page by the tenderer or his/their power of attorney holder. In case of power of attorney holder, an attested copy of power of attorney should be furnished.ii) Second envelope subscribing in bold letters **“SPECIFICATION AND PRICE SCHEDULE”** should contain detailed specifications and price schedule in original only duly filled in without leaving any column and line blank and signed on each page by the tenderer or his/their power of attorney holder.
- 5) The tender document can be purchased by the interested reputed manufacturers / traders by hand from the office of the undersigned from **09.11.2023** to **20.11.2023** (up to 1.00 P.M) during office hours on deposit of cost of tender document i.e. **Rs.2000/-** plus GST @ 18% amounting to **Rs.2360/-** in cash or in shape of A/c. payee demand draft drawn in favour of **“Odisha Construction Corporation Limited” - Project Account** on any Nationalized Bank / Scheduled Bank payable at Bhubaneswar (non-refundable) and production of attested copies of the following documents and verification thereof by the undersigned. The tender document can also be obtained by the interested reputed manufacturers / traders by registered post/speed post/courier on sending the cost of tender document i.e. **Rs.2000/-** plus GST @ 18% and postage charges of **Rs.100/-** amounting to **Rs.2460/-** in shape of A/C. payee demand draft drawn in favour of **“Odisha Construction Corporation Limited” - Project Account** on any Nationalized Bank / Scheduled Bank payable at Bhubaneswar (non-refundable) and sending attested copies of the following documents and verification thereof by the undersigned.

Signature of the tenderer or his/their  
power of attorney holder  
with designation & seal.

Senior Manager (Mech.)-I  
OCC Ltd, Central Workshop,  
Rasulgarh, Bhubaneswar-751010

- a. Valid GST Registration Certificate.
  - b. PAN Card
  - c. The bidders have to submit copies of purchase orders, credentials, certificates etc. in support of supply of similar items of magnitude minimum amounting to 5.00 lakh in last 5 financial years (i.e. from financial year 2018-19 to 2022-23 including current financial year 2023-24).
  - d. Tenderer should submit valid manufacturer / trader registration certificate
  - e. Tenderer should submit format of Bid Security Declaration from Bidder in lieu of EMD.
- 6) The tender document can also be downloaded from our Website [www.odishaconstruction.com](http://www.odishaconstruction.com) or Govt. of Odisha website [www.odishagov.nic.in](http://www.odishagov.nic.in) to submit the tender (**Bidders are requested to visit our website regularly for any changes since it will not be published in news paper again**). However, the cost of tender document i.e. **Rs.2000/-** plus GST @ 18% amounting to **Rs.2360/-** in shape of A/C. payee demand draft, as stated above in favour of "Odisha Construction Corporation Limited" - Project Account on any Nationalized Bank/ Scheduled Bank payable at Bhubaneswar (non-refundable) along with attested photo copies of all above documents should be submitted, while submitting tender in Envelope-I, otherwise, the tender will be cancelled. OCCL will not be responsible for missing of any page while downloading.
- 7) The tenders will be received up to **3.30 PM** on **20.11.2023** and same will be opened in the office of the undersigned on the same day at **4.00 PM** in presence of the tenderers or their authorized representatives, if they so desire. If there will be a public holiday on the last date of sale of tender document and receipt & opening of the tenders as specified above, the tender document will be sold and tenders will be received & opened on the next working day at the same time and venue.
- 8) The undersigned will not be responsible for any kind of delay in receipt of tenders by the postal/courier authorities.
- 9) The **PRICE SCHEDULE BID & TECHNICAL BID** will be opened on **20.11.2023 at 4.00 PM**. Then the documents in the first envelope submitted by the tenderers will be scrutinized preliminarily on the spot. The second envelope of the valid eligible tenders after preliminary scrutiny of the documents in the first envelope will be opened on the same day immediately subject to fulfilling the requirements mentioned in the tender schedule.
- 10) The materials should be supplied in finished / fully machined conditions by successful tenderer / supplier as per required dia, length and quantity and should strictly conform to relevant standards of Bureau of Indian Standard (BIS) as mentioned in detailed specification and price schedule.
- 11) The original test certificate of materials from a Govt./Govt. approved testing laboratory will be provided by the successful tenderer/ supplier along with supply of materials. The manufacturer's test certificate will have to be also furnished by the successful tenderer/ supplier. The purchaser is having the option to test the materials in any laboratory at the cost of the supplier and if the materials are not found in accordance with the specifications and grade in relevant Indian Standards, the materials will be rejected.
- 12) The materials will be guaranteed by the supplier against any defect for a period of 18 months from the date of supply or 12 months from the date of use, whichever is earlier. Guarantee certificate in this regard will accompany with supply of materials. If any defect is found in the materials within the guarantee period, the same will have to be replaced free of cost by the supplier.

**Signature of the tenderer or his/their  
power of attorney holder  
with designation & seal.**

**Senior Manager (Mech.)-I  
OCC Ltd, Central Workshop,  
Rasulgarh, Bhubaneswar-751010**

- 13) The rate of materials should be quoted by the tenderer on unit basis only. The same should be supplied by the successful supplier as per required dia, length and quantity in numbers as mentioned in detail specification and Price Schedule.
- 14) The tenderer will quote their rates F.O.R. OCCL Store, Central Workshop, Rasulgarh, Bhubaneswar-10 (Odisha) indicating separately the basic price, packing, forwarding, transportation, transit insurance, handling charges, taxes, duties, levies etc. strictly in the specifications and price schedule format in original. All columns and lines of the specification and price schedule should be filled in properly without leaving any thing blank. The details and rates of duties, taxes etc. should be indicated clearly in the specification and price schedule.
- 15) The tenderer should quote appropriate taxes with the offer.
- 16) The rates and amounts should be quoted both in figures and words in the price schedule. Any correction or overwriting in the specification and price schedule should be duly certified by the tenderer or his power of attorney holder. In case of any mismatch in figures and words, the rates in words will be considered. In case of any mismatch in rates and amount, the rate will be considered.
- 17) 90% payment will be made within 30 days of receipt, verification and acceptance of the complete materials along with bill, test certificate, guarantee certificate and other documents. Balance 10% will be released after 18 months of supply or 12 months from the date of commissioning whichever is earlier. However if a performance bank guarantee is received for 10% of the value of materials, the same will be released within 60 days from the date of receipt of materials.
- 18) The purchaser reserves the right to forfeit and encash the performance bank guarantee / EMD in full in case any casting is found defective and not replaced by the tenderer/supplier within a suitable time fixed by the corporation. Any repair to the casting shall be made only after approval of the purchaser. In this connection, the decision of the purchaser is final and binding on the tenderer/supplier.
- 19) Price escalation will not be allowed under any circumstances. The quoted rates will remain firm till execution of the work order.
- 20) The validity of the offer should be for a period of 120 (One hundred twenty) days from the date of opening of the tender.
- 21) The complete ordered quantity shall be supplied by the successful tenderer within 60 (Sixty) days from the date of issue of purchase order failing which the order is liable for cancellation without assigning any reason thereof by the purchaser. In case of cancellation of the order the EMD will be forfeited. In case of any delay in supply of material beyond the delivery schedule whatever may the reason, supplier shall be liable to pay L.D. @ 0.5% (Half percent) of the total order value per week of delay or part thereof subject to a maximum of 5% (Five percent) of the total order value.
- 22) Pre-delivery inspection (P.D.I) before despatch of the materials will be made at the manufacturer's works by the authorized representative of the purchaser / client / third party for which the manufacturer should intimate in writing for P.D.I. 10 days in advance regarding readiness for P.D.I.

**Signature of the tenderer or his/their  
power of attorney holder  
with designation & seal.**

**Senior Manager (Mech.)-I  
OCC Ltd, Central Workshop,  
Rasulgarh, Bhubaneswar-751010**

- 23) After submission of tender and before placing order, the bidder may be asked by the undersigned to attend techno-commercial discussions and reply to queries within a specified period. If the bidder fail to do so, the tender submitted by the bidder is liable to be cancelled.
- 24) Conditional offers with deviations will not be accepted. Those, who do not agree to the terms and conditions regarding payments, delivery and others, need not quote.
- 25) The authority reserves the right to accept/reject any or all tenders without assigning any reason thereof. The required quantity of materials can be splitted among the two or more tenderers. In this connection, the decision of purchaser is final and binding on the tenderer.
- 26) The duplicate copy of the order shall be signed by the supplier on each page with his seal as acceptance of the order and shall be returned to the purchaser within 07 (Seven) days of receipt of this order failing which the order is liable for cancellation.
- 27) Tender through fax/telex/telegram/e-mail will not be accepted.
- 28) Any dispute arising out of this tender or order thereof is to be settled in proper court under the jurisdiction of Odisha High Court at Cuttack or courts under the jurisdiction of Odisha High Court at Bhubaneswar only.

**Signature of the tenderer or his/their  
power of attorney holder  
with desianation & seal.**

**Senior Manager (Mech.)-I  
OCC Ltd, Central Workshop,  
Rasulgarh, Bhubaneswar-751010**

**ODISHA CONSTRUCTION CORPORATION LIMITED**  
(A GOVT. OF ODISHA UNDERTAKING)  
**CENTRAL WORKSHOP, RASULGARH,**  
**BHUBANESWAR-751010 (ODISHA).**

**DETAILED SPECIFICATION AND PRICE SCHEDULE FOR**  
**“SUPPLY OF CASTING ITEMS FOR SAPTAMATRUKA BARRAGE PROJECT( RIGHT ARM & LEFT ARM)”**  
**VIDE TCN No.OCC/CWS/PROC/ SMP-10 / 45 /2023-24 DATED.09.11.2023 DUE DATE OF OPENING ON DATED 20.11.2023**

Sl. No.	Description of Item	Part No	Unit	Qty. Reqd. in unit	Rate per unit in Rs.					Total amount in Rs. for full materials	
					Basic Price per unit	Packing, forwarding, transportation, transit insurance, handling charges, incidental charges etc.	GST as applicable	Total in figures	Total in words	In figure	In words

**STOPLOG AND LIFTING BEAM FOR SAPTAMATRUKA BARRAGE PROJECT (RIGHT ARM)**

1	230 x 100 X 20 TH. PL. BRONZE PAD LTB-1 OF IS : 318 (As per drawing in Annexure -I)	3-19	NOS.	16							
2	BUSH (FOR WHEEL) LTB-1 OF IS : 318 - 1981 (As per drawing in Annexure -II)	2-11	NOS.	4							
3	BUSH (FOR HOOK) AB-1 OF IS : 305 (As per drawing in Annexure -III)	3-3	NOS.	2							
4	BUSH FOR OPERATING ARM LTB-1 OF IS : 318 (As per drawing in Annexure -IV)	3-13	NOS.	1							
5	BUSH (STOPLOG LATCH (ARRANGEMENT) GR. AB – 1 OF IS : 305 (As per drawing in Annexure -V)	5-4	NOS.	16							

**12T ROPE DRUM HOIST TO OPERATE BARRAGE BAY GATE OF SAPTAMATRUKA PROJECT(RIGHT ARM)**

6	DIAL PLATE-3.15 THICK BRASS OF IS : 410 (As per drawing in Annexure -VI)	8-1	NOS.	6							
7	BUSH LTB-1 OF IS : 318 (As per drawing in Annexure -VII)	8-4	NOS.	36							

Signature of the tenderer or his/their  
power of attorney holder  
with designation & seal.

Senior Manager (Mech.)-I  
OCC Ltd, Central Workshop,  
Rasulgarh, Bhubaneswar-751010

Sl. No.	Description of Item	Part No	Unit	Qty. Reqd. in unit	Rate per unit in Rs.					Total amount in Rs. for full materials	
					Basic Price per unit	Packing, forwarding, transportation, transit insurance, handling charges, incidental charges etc.	GST as applicable	Total in figures	Total in words	In figure	In words

8	INDICATOR NEEDLE STR. STEEL (As per drawing in Annexure –VIII)	8-10	NOS.	6							
9	JAW CLUTCH STR. STEEL (As per drawing in Annexure –IX)	8-20	NOS.	6							
10	DOG CLUTCH (SLIDING) STR. STEEL (As per drawing in Annexure –X)	10-4	NOS.	6							
11	DOG CLUTCH (FIXED) STR. STEEL (As per drawing in Annexure –X)	10-5	NOS.	6							
12	SLIDER BUSH BRASS (As per drawing in Annexure –XI)	10-6	NOS.	12							
13	CHAIN SPROCKET(DRIVEN) STR. STEEL (As per drawing in Annexure –XII)	10-13	NOS.	6							
14	CHAIN WHEEL (DRIVING) STR. STEEL (As per drawing in Annexure –XIII)	10-14	NOS.	6							
15	Ø50 PULLEY WITH PIN STD. suitable Ø 4 mm wire rope STD.	11-11	NOS.	12							
16	HOOK PIN 45C8 IS : 2004 (As per drawing in Annexure –XIV)	4-2	NOS.	16							
17	BUSH GR. AB-2 IS : 305 (As per drawing in Annexure –XV)	4-4	NOS.	16							

**14T ROPE DRUM HOIST TO OPERATE BARRAGE BAY GATE OF SAPTAMATRUKA PROJECT(LEFT ARM)**

18	SPROCKET 13T STR. STEEL (As per drawing in Annexure –XVI)	8-16	NOS.	8							
19	SPROCKET 14T STR. STEEL (As per drawing in Annexure XVII)	8-17	NOS.	8							

Signature of the tenderer or his/their  
power of attorney holder  
with designation & seal.

Senior Manager (Mech.)-I  
OCC Ltd, Central Workshop,  
Rasulgarh, Bhubaneswar-751010



Sl. No.	Description of Item	Part No	Unit	Qty. Reqd. in unit	Rate per unit in Rs.					Total amount in Rs. for full materials	
					Basic Price per unit	Packing, forwarding, transportation, transit insurance, handling charges, incidental charges etc.	GST as applicable	Total in figures	Total in words	In figure	In words

20	PL Ø400-6 TH. ALUMN (As per drawing in Annexure -XVIII)	8-21	NOS.	8							
21	DOG CLUTCH (SLIDING) STR. STEEL (As per drawing in Annexure -XIX)	9-4	NOS.	8							
22	DOG CLUTCH (FIXED) STR. STEEL (As per drawing in Annexure -XIX)	9-5	NOS.	8							
23	SLIDER BUSH BRASS (As per drawing in Annexure -XX)	9-6	NOS.	16							
24	CHAIN SPROCKET(DRIVEN) STR. STEEL (As per drawing in Annexure -XXI)	9-13	NOS.	8							
25	CHAIN WHEEL (DRIVING)STR. STEEL (As per drawing in Annexure -XXII)	9-14	NOS.	8							
26	Ø50 PULLEY WITH PIN suitable Ø 4 mm wire rope STD.	10-11	NOS.	16							

**Signature of the tenderer or his/their power of attorney holder with designation & seal.**

**Senior Manager (Mech.)-I  
OCC Ltd, Central Workshop,  
Rasulgarh, Bhubaneswar-751010**

Annexure-I

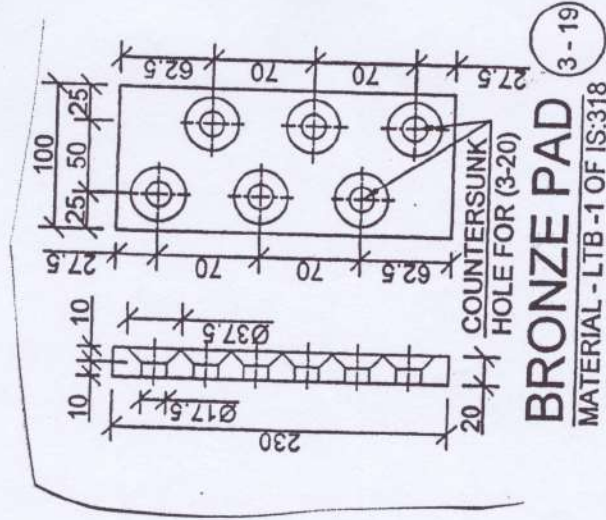

TOTAL QTY REQD. = 16 (SIXTEEN) NOS.

Note:- (3-20) - Countersunk screws M16.X45  
IS: 1365

STOPLOG FOR BARRAGE BAY & UNDER SLUICE  
GATES OF BARRAGE OF SAPTAMATRUKA  
BARRAGE PROJECT. [RIGHT ARM]  
OCCL.

*[Handwritten signature]*

Annexure - II

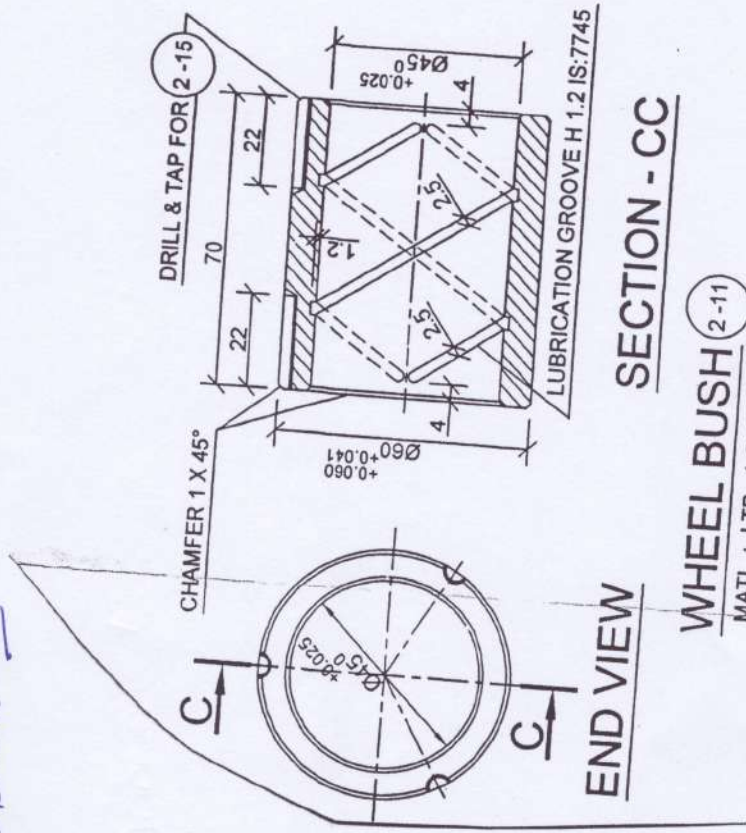

**WHEEL BUSH (2-11)**  
MATL. :- LTB - 1 OF IS:318

TOTAL QTY REQD. = 04 (FOUR) NOS.

Note :- (2-15) - Grob screw CM6 X 20 IS: 2388 - 6.6.

LIFTING BEAM OF STOPLOGS FOR BARRAGE  
BAY & UNDER SLICE GATES OF BARRAGE  
FOR SAPTAMATRUKA BARRAGE PROJECT  
[RIGHT ARM] OCCL.

*[Handwritten signature]*





Annexure-IV

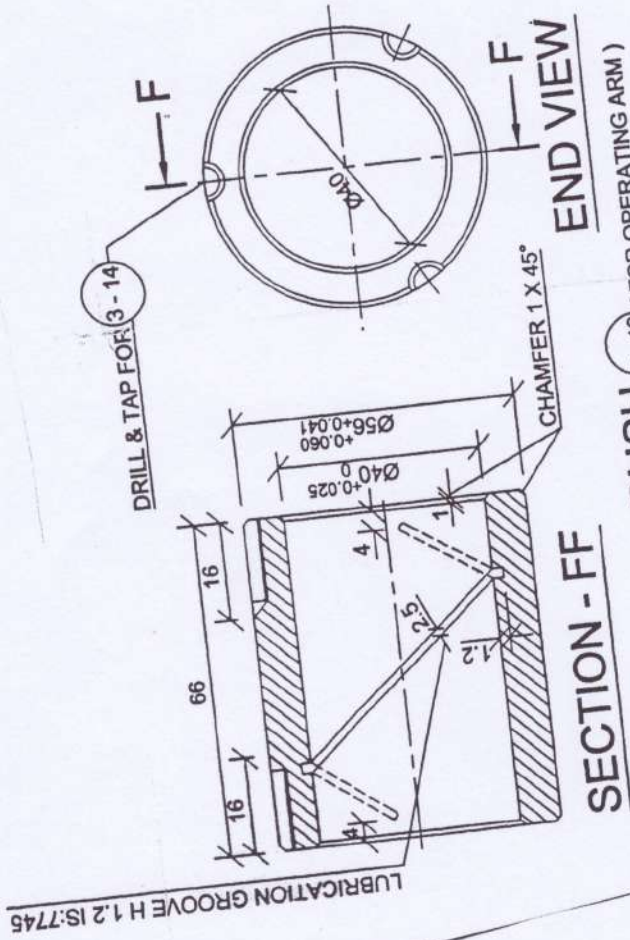

MATERIAL - LTB-1 OF IS:318

TOTAL QTY REQD. = 01 (ONE) NOS.

Note:- (3-14) - Grob screw CM 6 X 16 IS: 6094-10.9

LIFTING BEAM FOR STORLOGS FOR BARRAGE  
BAY 6 UNDER SLICE GATES OF BARRAGE  
OF SAPTAMATRUKA BARRAGE PROJECT  
[RIGHT ARM] OCCL.

*[Handwritten signature]*

Annexure - A

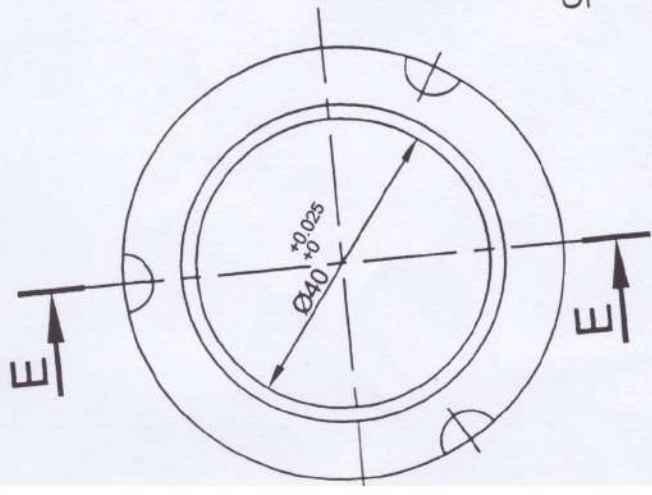
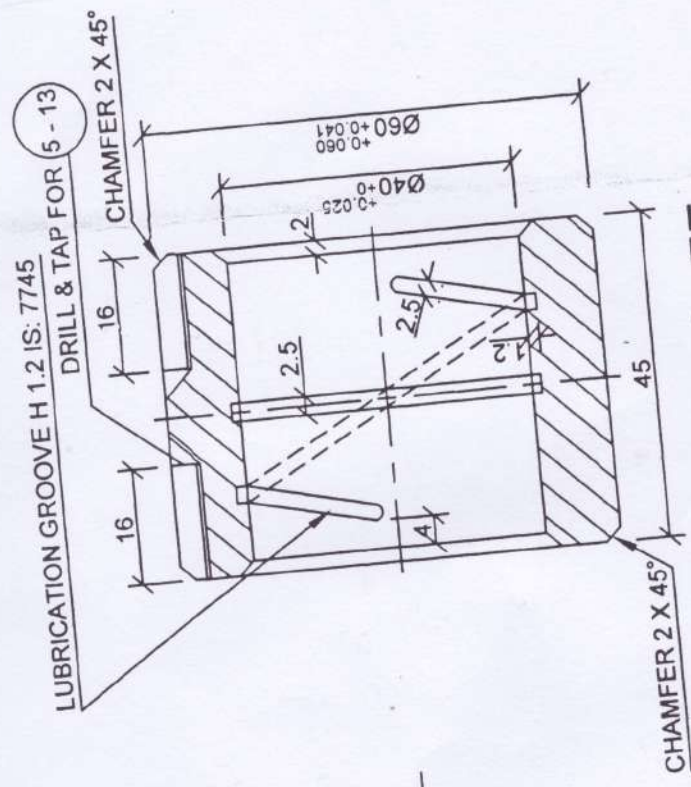

BUSH 5-4

MATERIAL - GR. AB-1 OF IS: 305 - 1981

TOTAL QTY REQD. = 16 (SIXTEEN) NOS.

Note: (5-13) - Grub screw EM 8 X 16 IS; 6094 - 10.9.

STORLOG FOR BARRAGE BAY & UNDER  
 SLUICE GATES OF BARRAGE OF SAPTAM -  
 - TRUKA BARRAGE PROJECT [RIGHT ARM]  
 OCCL.





Annexure - VII

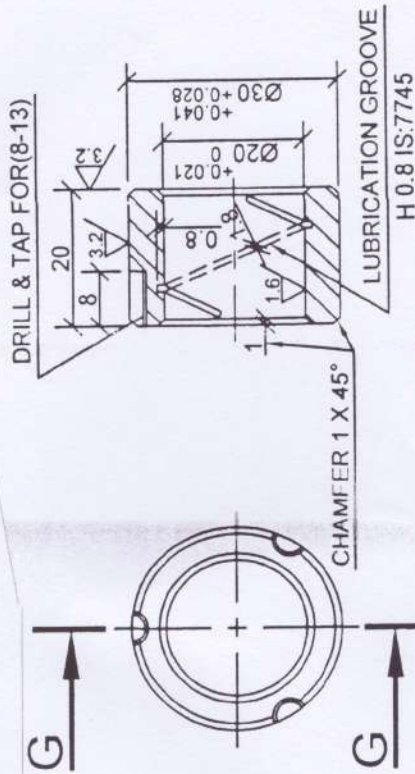

END VIEW SECTION - GG

BUSH 84

MATERIAL: LTB-1 OF IS: 318

TOTAL QTY REQD. = 36 (THIRTY SIX) NOS.

Note: (8-13) - Gsub 2x5x8 IS: 6094 - 10.9

12T ROPE DRUM HOIST OF BARRAGE BAY  
GATE OF SAPTAMATROKA BARRAGE  
PROJECT [RIGHT ARM] OCCL.



# Annexure - VI

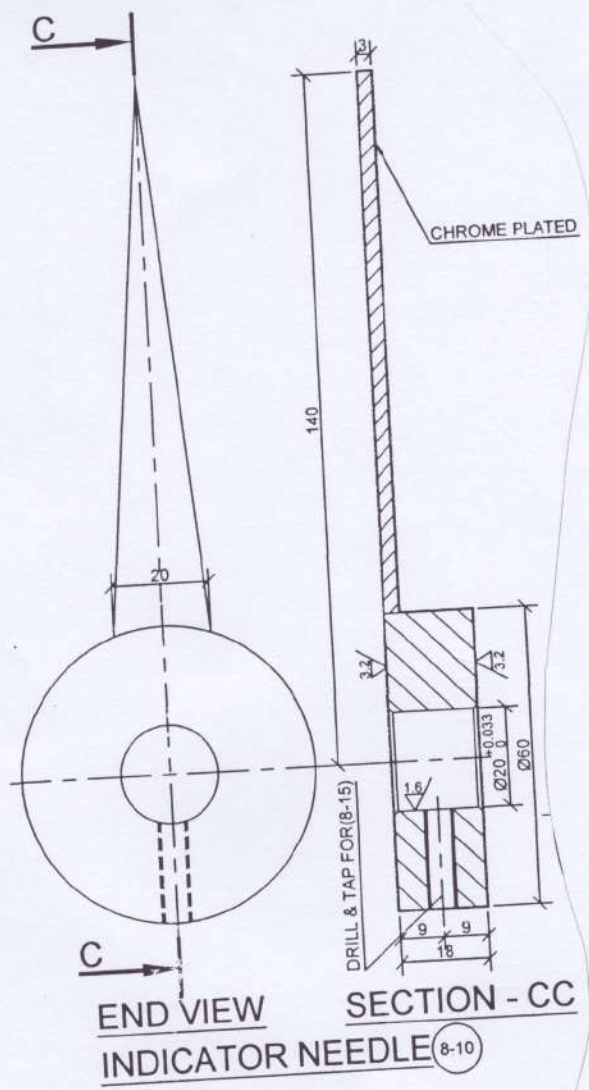

TOTAL QTY REQD. = 06 (SIX) NOS.

Note :- (8-15) - Grub screw M6 X 20 IS: 6094-10.9

*Handwritten signature*

12 T ROPE DRUM HOIST OF BARRAGE  
 BAY GATE OF SAPTA MATRUKA  
 BARRAGE PROJECT [RIGHT NO. 7

Annexure - IX

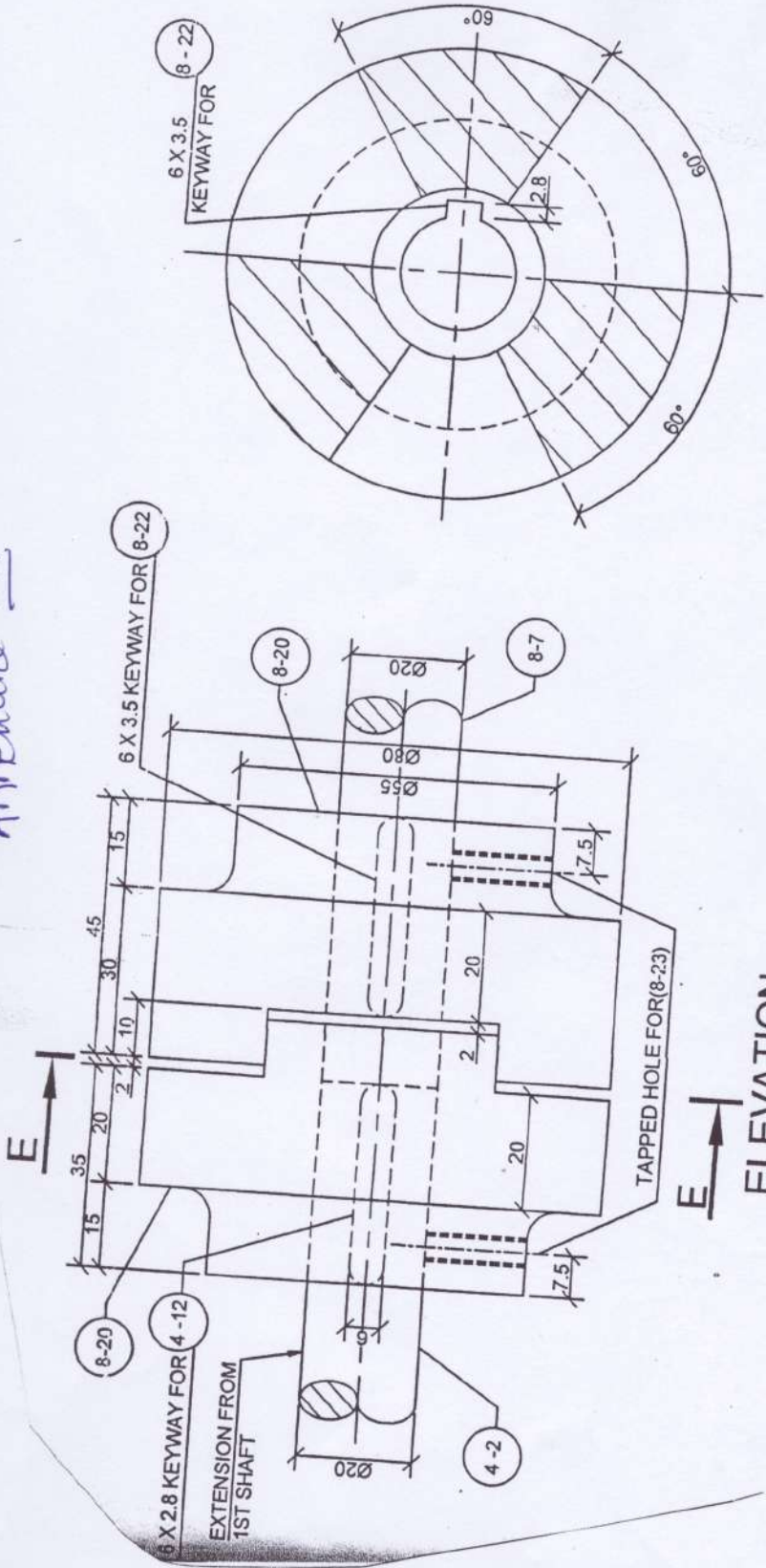

SECTION - EE

ELEVATION

JAW CLUTCH ASSEMBLY (8-20)

TOTAL QTY. REQD. = 06 (SIX) NOS.

Note: (8-23) - Grob screw CMS X 15 IS: 6094 - 10.9

1<sup>ST</sup> ROPE DRUM HOIST OF BARRAGE  
 BAY GATE OF SAPTAMATRUKA  
 BARRAGE PROJECT [RIGHT ARM]  
 OCCL.

*Handwritten signature*

Annexure - X

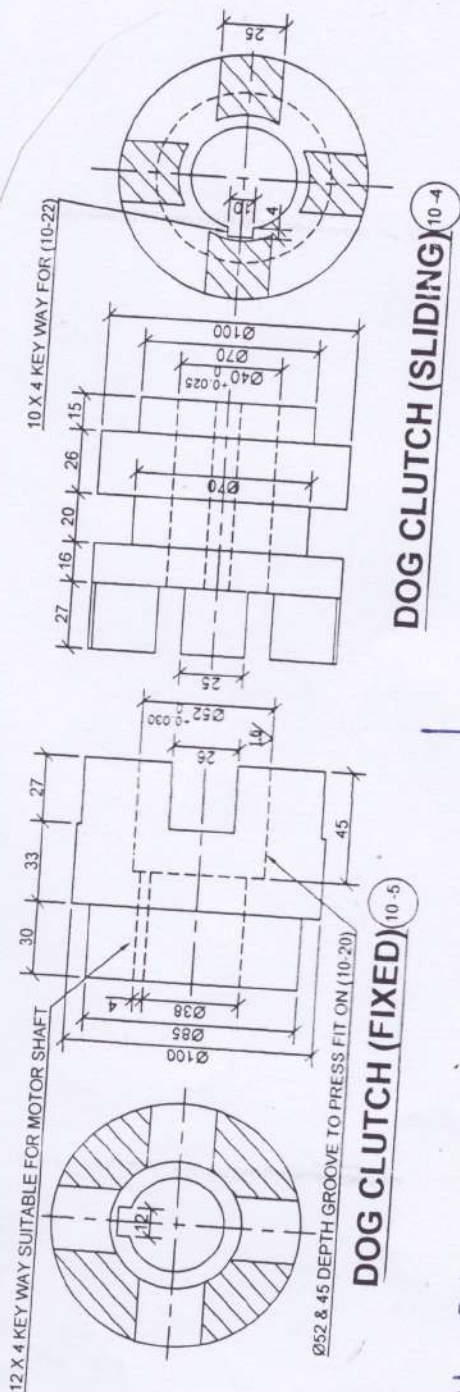

TOTAL QTY REQD = 06 (SIX) NOS.

TOTAL QTY REQD = 06 (SIX) NOS.

*Signature*

12 T ROPE DRUM HOIST OF BARRAGE BAY  
 GATE OF SAPTA MATRUKA BARRAGE PROJECT  
 [RIGHT ARM].  
 OCCL.



Annexure - XI

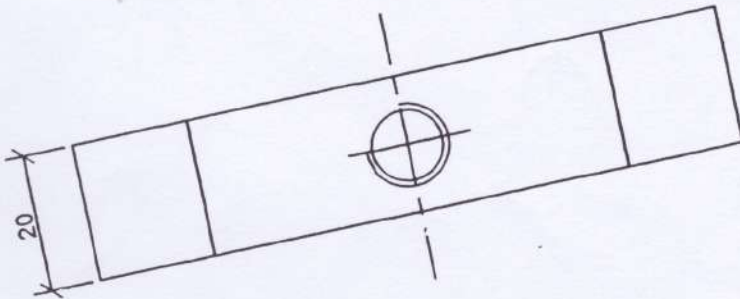
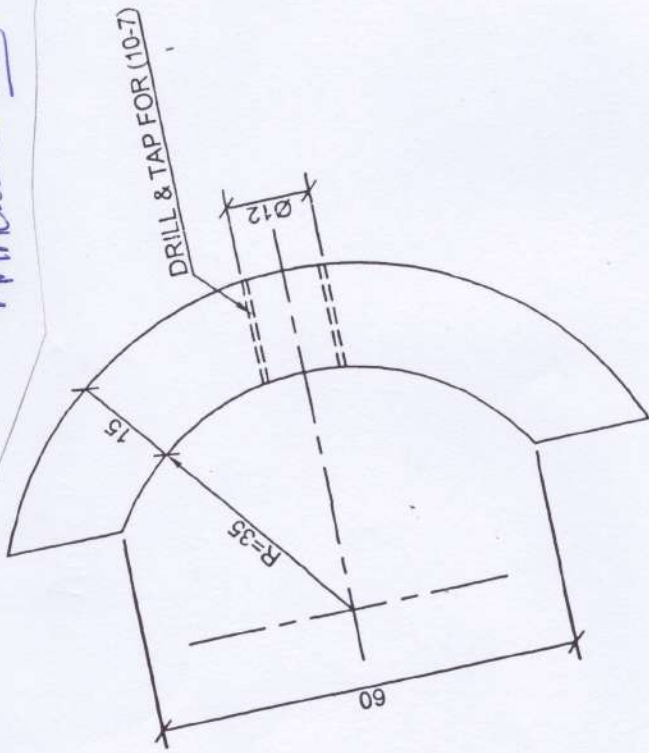

**SLIDER BUSH** (10-6)

MATERIAL:- BRASS

TOTAL QTY REQD = 12 (TWELVE) NOS.

12T ROPE DRUM HOIST OF BARRAGE BAY  
GATE OF SAPTA MATRUKA BARRAGE  
PROJECT [RIGHT ARM]  
OCCL.

Annexure - XII

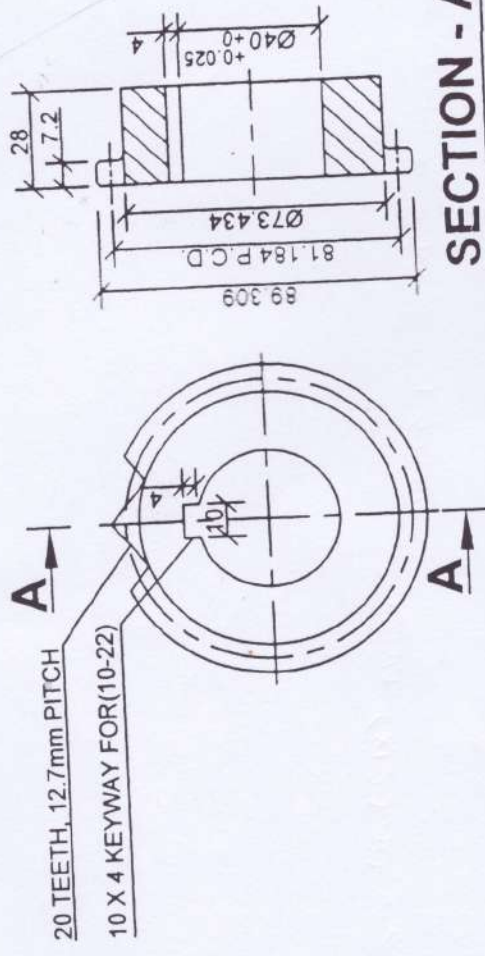

SECTION - AA

CHAIN SPROCKET (DRIVEN) (10-13)

SPECIFICATION:-  
MATERIAL - CAST STEEL/STR. STEEL  
PITCH - 12.7 FOR CHAIN 081-1 IS:2403  
NO OF TEETH - 20

TOTAL QTY REQD. = 06 (SIX) NOS.

12 T ROPE DRUM HOIST OF BARRAGE  
BAY GATE OF SAPTAMATRUKA BARRAGE  
PROJECT [RIGHT ARM]  
OCCL





Annexure - 2EV

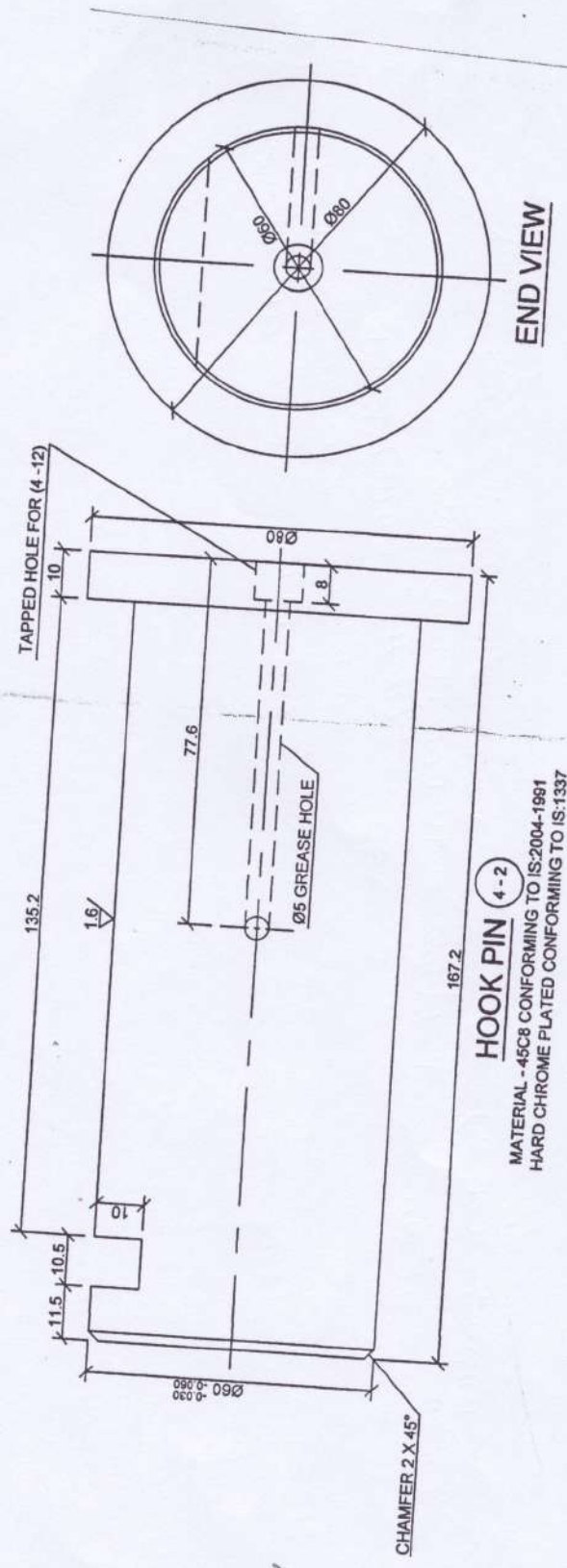

TOTAL QTY REQD. = 16 (SIXTEEN) NOS.

Note :- (4-12) - conical head grease nipple AMIO XI IS: 4009 (Part-11)  
12 T & 14 T ROPE DRUM HOIST OF SAPTAMATRAKA  
BARRAGE PROJECT [RIGHT ARM] OCCL.

*[Handwritten signature]*

Annexure - XIV

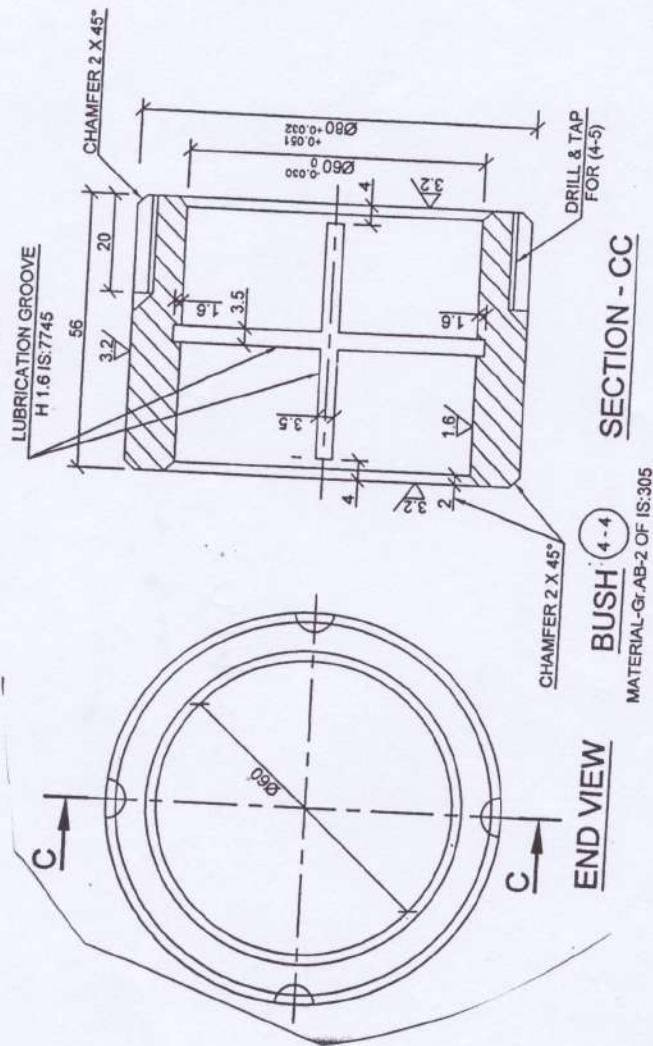

TOTAL QTY REQD. = 16 (SIXTEEN) NOS.

Note :- (4-5) - Grob screw CM 8 X 16 IS: 2388 - 6.6

12 T 8 HT ROPE DRUM HOIST OF  
SAPTAMATRUKA BARRAGE PROJECT,  
CRIGHT ARM) OCCL.



Annexure - A VI

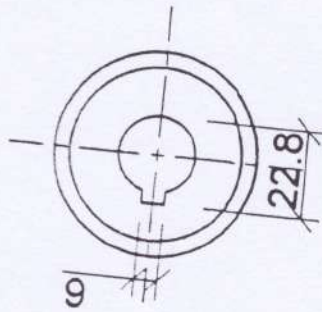
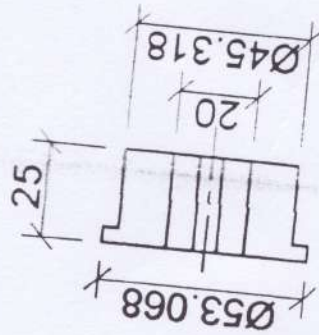

*[Signature]*

SPROCKETS	NO OF TEETH	PITCH	PCD
SPROCKET (SP2) CONNECTED TO WORM GEAR.	13	12.7	53.0682

**SPROCKET DETAIL - (8-16)**

TOTAL QTY REQD = 08 (EIGHT) NOS.

1HT ROPE DRUM HOIST OF BARRAGE BAY GATE OF SAPTAMATRUKA BARRAGE PROJECT [LEFT ARM], OCCL.

Anneure - XREF

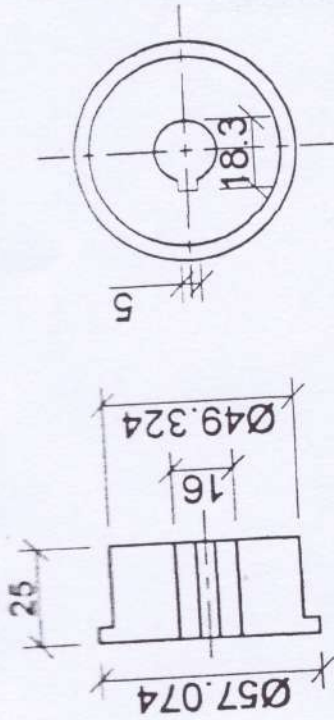

SPROCKETS	NO OF TEETH	PITCH	PCD
SPROCKET (SPL) CONNECTED TO PIW2 SHAFT	14	12.7	57.0738

### SPROCKET DETAIL - (8-17)

TOTAL QTY REQD. = 08 (EIGHT) NOS.

*[Signature]*

1HT ROPE DRUM HOIST OF BARRAGE  
 BAY GATE OF SAPTAMATRUKA  
 BARRAGE PROJECT [LEFT ARM].  
 OCCL.

Annexure - XVIII

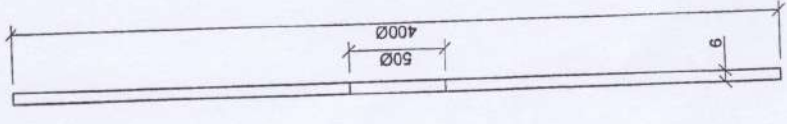

VIEW - DD

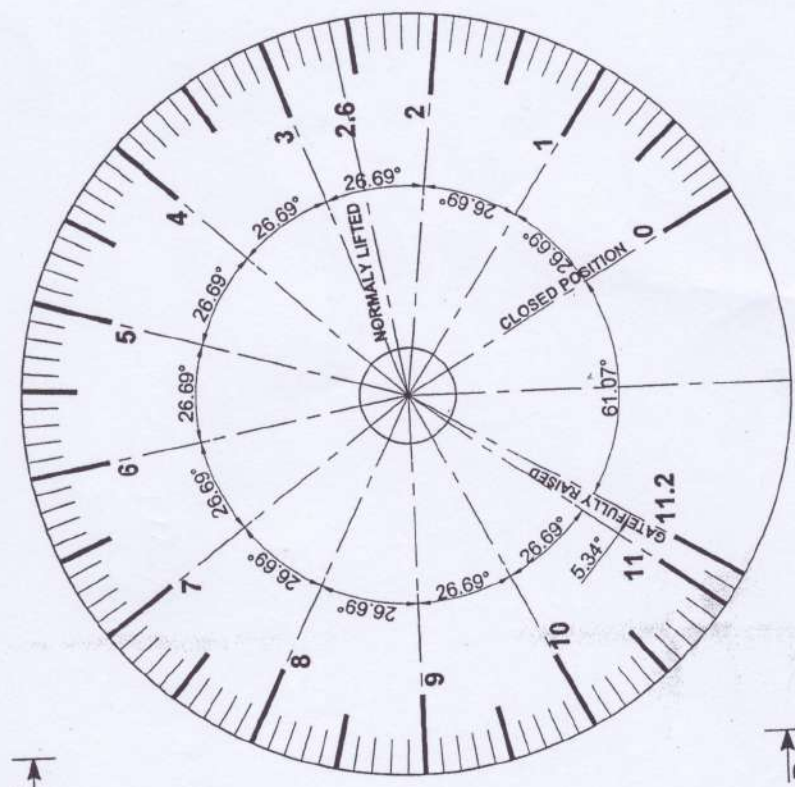

DIAL (8-21)

ENAMELED PLATE  
MARKING ARE TO BE ENGRAVED

TOTAL QTY READ = 08 (EIGHT) NOS.

1#T ROPE DRUM HOIST OF BARRAGE  
BAY GATE OF SAPTAMATRUKA  
BARRAGE PROJECT [LEFT ARM]  
OCCL



Annexure - AIA

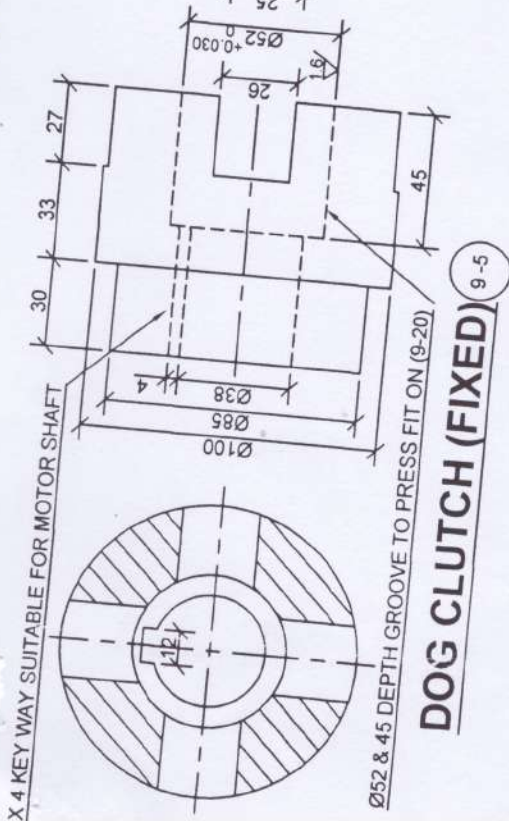

TOTAL QTY REQD. = 08 (EIGHT) NOS.

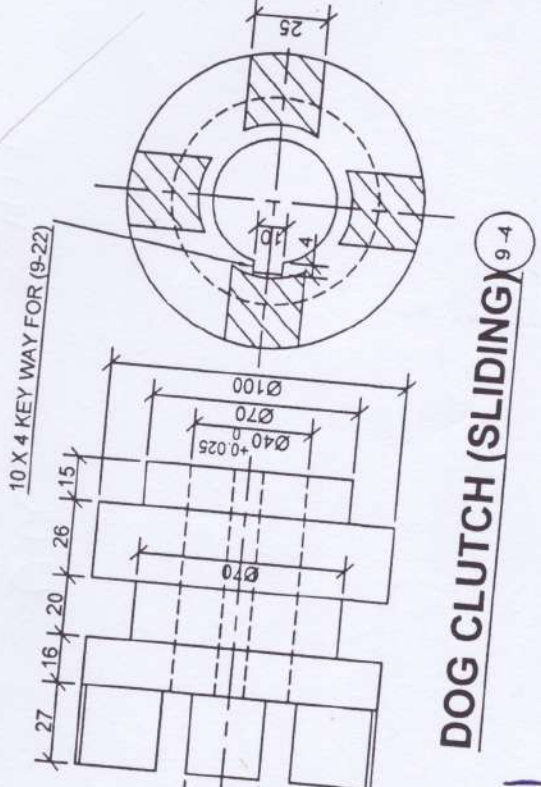

TOTAL QTY. REQD. = 08 (EIGHT) NOS.

*Handwritten signature*

14 T ROPE DRUM HOIST OF BARRAGI  
 BAY GATE OF SAPTA MARKUKA BARRAG  
 PROJECT [LEFT ARM]  
 OCCU

Annexure - 7A

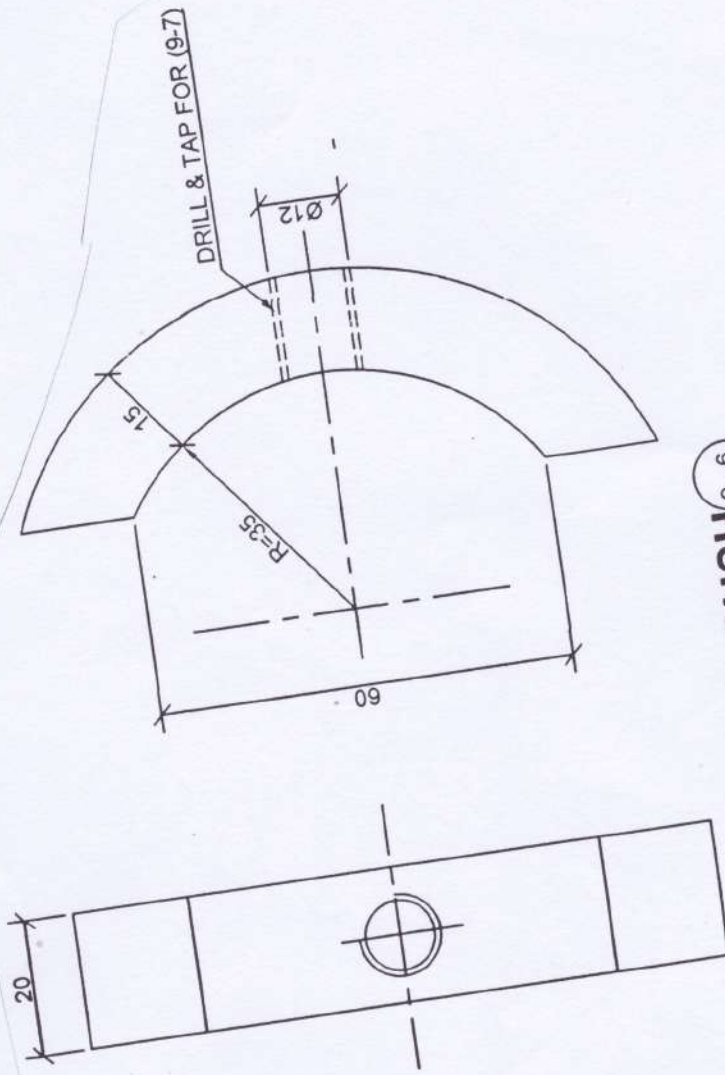

*[Handwritten signature]*

**SLIDER BUSH** <sup>9-6</sup>  
MATERIAL - BRASS

TOTAL QTY REQD. = 16 (SIXTEEN) NOS.

IHT ROPE DRUM HOIST OF BARRAGE  
BAY GATE OF SAPTAMATRUKA  
BARRAGE PROJECT - [LEFT ARM]  
OCCL.

Amennure - XXI

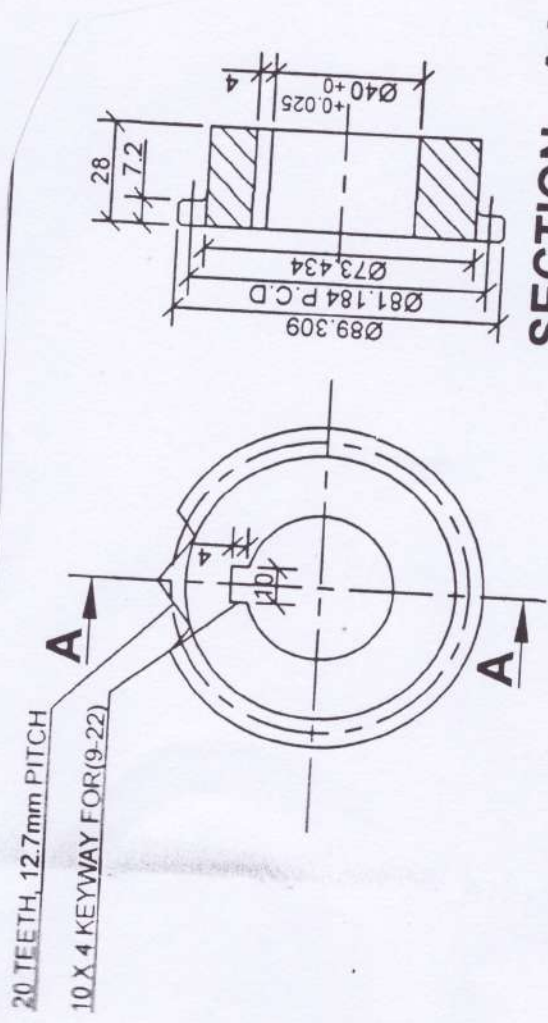

**SECTION - AA**

**CHAIN SPROCKET (DRIVEN)**

9-13

SPECIFICATION:-  
MATERIAL - CAST STEEL/STR. STEEL  
PITCH - 12.7 FOR CHAIN 081-1 IS:2403  
NO OF TEETH - 20

TOTAL QTY REQD = 08 (EIGHT) NOS.

INT ROPE DRUM HOIST OF BARRAGE  
BAY GATE OF SAPTAMATRUKA BARRAGE  
PROJECT [LEFT ARM]  
OCCL.



Annexure - XXII

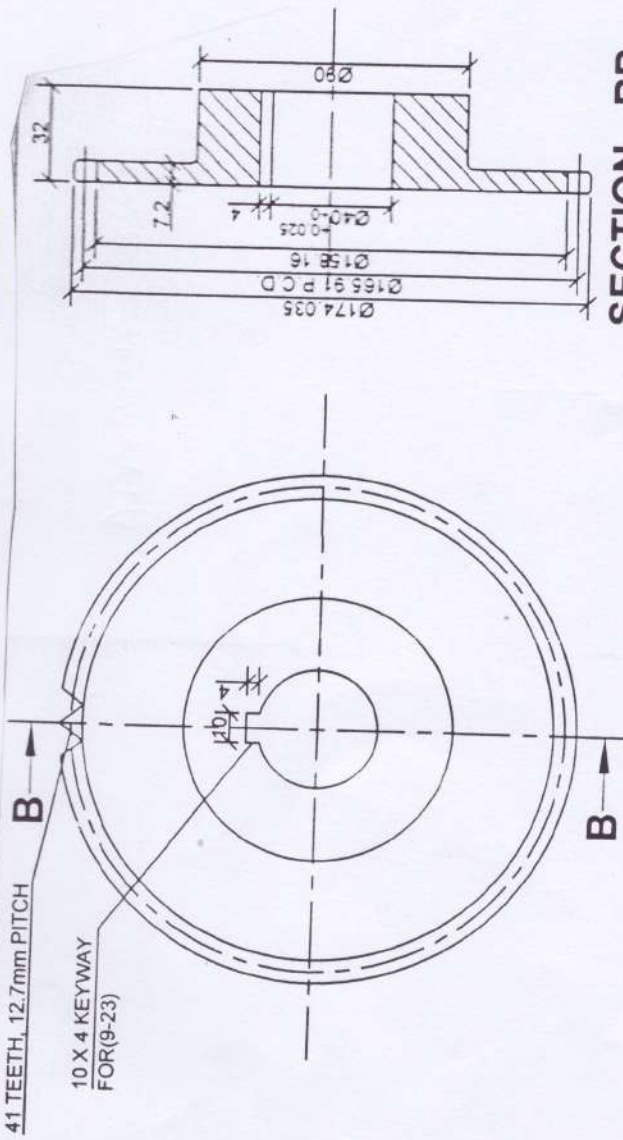

**CHAIN WHEEL (DRIVING)** 9-14

SPECIFICATION:-  
MATERIAL - CAST STEEL/STR. STEEL  
PITCH - 12.7 FOR CHAIN 081-1 IS:2403  
NO OF TEETH - 41

TOTAL QTY REQD. = 08 (EIGHT) NOS.

*[Handwritten signature]*

1HT ROPE DRUM HOIST OF BARRAGE  
BAY GATE OF SPTAMATROKA BARRAGE  
PROJECT [LEFT ARM]  
OCCL.