

ODISHA CONSTRUCTION CORPORATION LTD.
(A GOVT. OF ODISHA UNDERTAKING)
CENTRAL WORKSHOP, RASULGARH,
BHUBANESWAR-751010 (ODISHA)

TENDER DOCUMENT FOR

**“SUPPLY OF RUBBER SEALS REQUIRED FOR SAPTAMATRUKA BARRAGE PROJECT (LEFT
ARM) ”**

The tender document comprises of the following:

1)	Tender call notice No.OCC/CWS/PROC/SMP-08 (Vol.II)/ 43 /2023-24 dated 07.11.2023	01 (One) sheet
2)	Terms and conditions	03 (Three) sheets
3)	Drawing	02 (Two) sheets
4)	Price schedule	01 (One) sheets

	Total:	07 (Seven) sheets

Signature of the tenderer or
His/their Power of attorney holder
with designation & seal.

Senior Manager (Mech.)-I
OCC Ltd, Central Workshop,
Rasulgarh, Bhubaneswar-10.

ODISHA CONSTRUCTION CORPORATION LTD.
(A GOVT. OF ODISHA UNDERTAKING)
CENTRAL WORKSHOP, RASULGARH,
BHUBANESWAR-751010 (ODISHA)

Tender Call Notice No. OCC/CWS/PROC/SMP-08(Vol.II)/ 43 /23-24 Dtd. 07.11.2023

Sealed tenders in conformity with the term & conditions, drawings and specifications in tender documents are invited from reputed manufacturers / authorized traders for **"SUPPLY OF RUBBER SEALS REQUIRED FOR SAPTAMATRUKA BARRAGE PROJECT (LEFT ARM) "** as per details below:

Cost of tender document (Non-refundable)	Sale of tender document		Earnest money deposit (EMD) required	Receipt of tender	Opening of Technical & price bid of tender
Rs. 600/- - GST @ 18% Rs.708/- - by hand or Rs.808/- - by Regd. Post/ courier	From 07.11.2023	To 16.11.2023 up to 1.00PM	1(One)% of the total quoted value including GST	Up to 3.30 P.M. on 16.11.2023	At 4.00 PM On 16.11.2023

The tender document can be purchased by the interested reputed manufacturers/ authorized traders by hand from the office of the undersigned on deposit of cost of tender document i.e. **Rs.600/-** plus GST @ 18% amounting to **Rs.708/-** in cash or in shape of A/c. payee demand draft drawn in favour of "Odisha Construction Corporation Limited-Project account" on any Nationalised Bank/ scheduled bank payable at Bhubaneswar (Non-refundable) and production of attested copies of the following documents and verification thereof by the undersigned. The tender document can also be obtained by the interested reputed manufacturers/ authorized traders by registered post/courier on sending the cost of tender document i.e. **Rs.708/-** plus postage charges of **Rs.100/-** amounting to **Rs.808/-** in shape of A/c. payee demand draft drawn as stated above and attested copies of the following documents and verification thereof by the undersigned. The undersigned will not be responsible for any kind of delay by the postal/courier authorities.

1. Valid GST Registration certificate.
2. PAN Card.
3. The bidders have to submit copies of purchase order, credentials, certificates etc. in support of supply of similar items of magnitude minimum amounting to 2.00 lakh in any one year of last 5 financial years (i.e, from financial year 2018-19 to 2022-23 including current financial year 23-24).
4. Tenderer should submit valid manufacturer / trader registration certificate.

The tender document can also be downloaded from our Website www.odishaconstruction.com or Govt. of Odisha website www.odishagov.nic.in to submit the tender (**Bidders are requested to visit our website regularly for any changes**). However, the cost of tender document i.e. **Rs.600/-** plus GST @ 18% amounting to **Rs.708/-** in cash or in shape of A/c payee demand draft as stated above in favour of "Odisha Construction Corporation Limited- Project Account" on any Nationalised Bank/ Scheduled Bank payable at Bhubaneswar (Non-refundable) along with attested photo copies of all above documents should be submitted while submitting the tender in Envelope-I. Otherwise, the tender will be cancelled & OCCL will not be responsible for missing of any page while downloading. If there will be a public holiday on the last date of sale of tender document and receipt & opening of the tender as specified above, the tender document will be sold and tender will be received & opened on the next working day at the same time and venue.

The SSI/NSIC/MSME units participating in tender are not entitled for exemption from payment of EMD / Security Deposits / Tender Paper costs as communicated vide DOWR Letter No. IIM-24/2018-14318/WR dated 24.05.2018 & Head Office, OCCL Letter No.5502/OCC/ CW-02/09(Vol-V)(WE) dated 30.05.2018.

The tenders will be opened in the presence of the tenderers or their authorized representatives, if they so desire. Tender through Fax/Telex/telegram/e-mail will not be accepted.

The undersigned reserves the right to accept or reject any or all tender without assigning any reason thereof.

Signature of the tenderer or
His/their Power of attorney holder
with designation & seal.

Senior Manager (Mech.)-I
OCC Ltd, Central Workshop,
Rasulgarh, Bhubaneswar-10.

ODISHA CONSTRUCTION CORPORATION LTD.
(A GOVT. OF ODISHA UNDERTAKING)
CENTRAL WORKSHOP, RASULGARH,
BHUBANESWAR-751010 (ODISHA)

TERMS AND CONDITIONS OF TENDER FOR
“SUPPLY OF RUBBER SEALS REQUIRED FOR SAPTAMATRUKA BARRAGE PROJECT (LEFT ARM)”

1. Reputed manufacturers/ authorized traders having supplied similar items of similar magnitude earlier and satisfactorily accepted by the clients will be eligible to participate in the tender. The copies of purchase orders, credentials, certificates etc. in support of similar supply and satisfactory performance thereof will be furnished along with the tender.
2. Tender should be submitted in two bid system in two separate sealed covers and both will be submitted in a single sealed outer cover subscribing in bold letters as **“SUPPLY OF RUBBER SEALS REQUIRED FOR SAPTAMATRUKA BARRAGE PROJECT (LEFT ARM)”** and also the date of opening of tender. The name and address of the tenderer should not be written on outer cover. Only the name and address of the purchaser should be written on the outer cover.
3. The tenderer should submit Earnest Money Deposit (EMD) @ 1(One)% of the total quoted value along with the tender in shape of A/C payee Demand Draft drawn in favour of “Odisha Construction Corporation Limited” - Project Account on any Nationalised Bank / Scheduled bank payable at Bhubaneswar. The tenders received without EMD will be out rightly rejected. EMD of the unsuccessful tenderers will be released only after finalization of the tender.
4.
 - i) The first envelope super scribing in bold letters as **“TECHNICAL BID”** should contain the following:
 - a. EMD of 1% as per clause- 3 above.
 - b. Attested copy of valid GST registration certificates. The tenderer will mention his GSTIN in his tender clearly without which the tender will not be taken into consideration.
 - c. Attested copy of PAN Card.
 - d. Attested copies of purchase orders, credentials, certificates in support of similar supply and magnitude and satisfactory performance thereof.
 - e. Complete tender document in original including terms and conditions but without detailed specifications and price schedule duly signed on each page by the tenderer or his power of attorney holder. In case of power of attorney holder, the attested copy of power of attorney should be furnished.
 - ii) Second envelope subscribing in bold letters **“SPECIFICATION AND PRICE SCHEDULE”** should contain detailed specifications and price schedule in original only duly filled in without leaving any column and line blank and signed on each page by the tenderer or his power of attorney holder.
5. The tender document can be purchased by the interested reputed manufacturers/ authorized traders by hand from the office of the undersigned from **07.11.2023** to **16.11.2023** (up to **1.00 PM**) during office hours on deposit of cost of tender document i.e. **Rs.600/-** plus GST @ 18% amounting to **Rs.708/-** in cash or in shape of A/c. payee demand draft drawn in favour of “Odisha Construction Corporation Limited-Project account” on any nationalized bank/ schedule bank payable at Bhubaneswar (non-refundable) and production of attested copies of the following documents and verification thereof by the undersigned. The tender document can also be obtained by the interested reputed manufacturers/ authorized traders by registered post / courier on sending the cost of tender document i.e. **Rs.600/-** plus GST @ 18% plus postage charges of **Rs.100/-** amounting to **Rs.808/-** in shape of A/c. Payee demand draft drawn in favour of “Odisha Construction Corporation Limited – Project account” on any nationalized bank/schedule bank payable at Bhubaneswar (non-refundable) and sending attested copies of the following documents and verification thereof by the undersigned.

Signature of the tenderer or
His/their Power of attorney holder
with designation & seal.

Senior Manager (Mech.)-I
OCC Ltd, Central Workshop,
Rasulgarh, Bhubaneswar-10.

1. Valid GST Registration certificate.
 2. PAN Card.
 3. The bidders have to submit copies of purchase order, credentials, certificates etc. in support of supply of similar items of magnitude minimum amounting to 2.00 lakh in any one year of last 5 financial years (i.e. from financial year 2018-19 to 2022-23 including current financial year 2023-24).
 4. Tenderer should submit valid manufacturer / trader registration certificate.
6. The tender document can also be downloaded from our Website www.odishaconstruction.com to submit the tender. However, the cost of tender document i.e. **Rs.600/-** plus GST @ 18% amounting to **Rs.708/-** in shape of A/c payee demand draft as stated above in favour of "Odisha Construction Corporation Limited- Project Account" on any Nationalised Bank/ Scheduled Bank payable at Bhubaneswar (Non-refundable) along with attested photo copies of all above documents should be submitted while submitting the tender in Envelope-I. Otherwise, the tender will be cancelled. OCCL will not be responsible for missing of any page while downloading. If there will be a public holiday on the last date of sale of tender document and receipt & opening of the tender as specified above, the tender document will be sold and tender will be received & opened on the next working day at the same time and venue.
7. The tenders will be received up to **3.30 PM** on **16.11.2023** and will be opened in the office of the undersigned on the same day at **4.00 PM** in presence of the tenderers or their authorized representatives, if they so desire.
8. The undersigned will not be responsible for any kind of delay by the postal/courier authorities.
9. The first envelope will be opened on **16.11.2023 4.00 PM** first. Then the documents in the first envelope submitted by the tenderers will be scrutinized preliminarily on the spot. The second envelope of the valid eligible tenders after preliminary scrutiny will be opened on the same day immediately subject to fulfilling the requirements mentioned in the tender.
10. Rubber seals shall be strictly as per IS: specification and size as mentioned in the drawing and price schedule format enclosed to the tender schedule.
11. Original test certificate of materials confirming to relevant IS: specification and grade for physical property will be provided by the successful tenderer from Govt./Govt. approved testing laboratory along with supply of materials. The purchaser is having the option to test the materials in any laboratory at the cost of the supplier and if the materials are not found in accordance with the BIS specifications and size, the materials will be rejected.
12. The materials shall be inspected at the time of receipt at OCCL store, Central Workshop, Rasulgarh, Bhubaneswar. If the materials are not found in accordance with proper IS specifications and drawings, the same shall be out rightly rejected.
13. The materials will be guaranteed by the supplier against any defect for a period of 18 months from the date of supply or 12 months from the date of use, whichever is earlier. Guarantee certificate in this regard will accompany with supply of materials. If any defect is found in the materials within the guarantee period, the same will have to be replaced free of cost by the supplier within a suitable time fixed by the purchaser.
14. The tenderer will quote their rates F.O.R. OCCL Store, Central Workshop, Rasulgarh, Bhubaneswar-10 (Odisha) indicating separately the basic price & packing, forwarding, transportation, transit insurance, handling charges & taxes, duties, levies etc. strictly in the detailed specifications and price schedule format in original. All columns and lines of the price schedule should be filled in properly without leaving any thing blank. The details and rates of duties and taxes should be indicated clearly in the price schedule. **After finalization of tender, the quantity of rubber seals to be ordered may increase /decrease as per decision of the purchaser.**
15. The tenderer should quote appropriate taxes with the offer.

Signature of the tenderer or
His/their Power of attorney holder
with designation & seal.

Senior Manager (Mech.)-I
OCC Ltd, Central Workshop,
Rasulgarh, Bhubaneswar-10.

16. 90% payment will be made within 30 (Thirty) days of receipt, verification and acceptance of the complete materials along with bill, test certificate, guarantee certificate and other documents. Balance 10% will be released after 18 months of supply or 12 months from the date of commissioning whichever is earlier. However if a performance bank guarantee is received for 10% of the total basic cost, the same will be released within 60 days from the date of receipt of materials.
17. Price escalation will not be allowed under any circumstances. The quoted rates will remain firm till execution of the work order.
18. The validity of the offer should be for a period of 120 (One hundred twenty) days from the date of opening of the tender.
19. The complete ordered quantity is to be supplied within 60 (Sixty) days from the date of issue of the purchase order, failing which the order is liable for cancellation without assigning any reason thereof by the purchaser. In case of cancellation of the order the EMD will be forfeited. In case of any delay in supply of materials beyond the delivery schedule, supplier shall be liable to pay L.D. @ 0.5% (Half percent) of the total ordered value per week of delay or part thereof subject to maximum of 5% (Five percent) of the total ordered value. Thereafter, the order may be cancelled with the discretion of purchaser.
20. Conditional offers with deviations will not be accepted. Those, who do not agree to the terms and conditions regarding payments, delivery and others, need not quote.
21. The authority reserves the right to accept/reject any or all quotations without assigning any reason thereof.
22. Tender through fax/telex/telegram/e-mail will not be accepted.
23. Any dispute arising out of this tender or order thereof is to be settled in proper court under the jurisdiction of Odisha High Court at Cuttack or courts under the jurisdiction of Odisha High Court at Bhubaneswar only.

Signature of the tenderer or
His/their Power of attorney holder
with designation & seal.

Senior Manager (Mech.)-I
OCC Ltd, Central Workshop,
Rasulgarh, Bhubaneswar-10.

ODISHA CONSTRUCTION CORPORATION LIMITED
(A GOVT. OF ODISHA UNDERTAKING)
CENTRAL WORKSHOP, RASULGARH,
BHUBANESWAR-751010 (ODISHA)

Sl. No.	Description of Item	Unit	Qty.	Rate per unit in Rs.					Total amount in Rs. for full materials	
				Basic Price per unit	P & F, transportation, transit insurance etc.	GST as applicable	Total in figures	Total in words	In figure	In words
1	Bottom Seal – 10306 mm long of Natural or Synthetic Rubber confirming to IS : 11855 - 1986 (As per drawing in Annexure-I)	Nos.	8							
2	Side Seal – 2655 mm long of natural or Synthetic Rubber confirming to IS : 11855 – 1986 (As per drawing in Annexure-II)	Nos.	16							
3	Spring loaded double leaf built up oil seal OD-100, 15 width for shaft Dia - 70	Nos.	64							
4	Ø 3 mm Rubber "O" ring ID 125 mm , OD – 131 mm	Nos.	64							

Signature of the tenderer or his/their
power of attorney holder
with designation & seal.

Senior Manager (Mech.)-I
OCC Ltd, Central Workshop,
Rasulgarh, Bhubaneswar-751010

Annexure-I

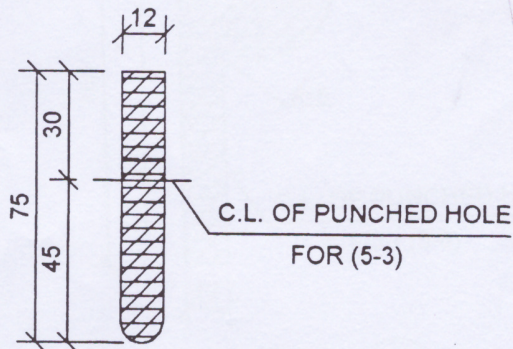

BOTTOM SEAL (5-1)

MATERIAL :- NATURAL OR SYNTHETIC RUBBER
CONFORMING TO IS:11855 - 1986
LENGTH OF EACH - 10306mm
NOS. REQD./GATE - 1 (ONE)

TOTAL QTY REQD. = 08 (EIGHT) NOS.

Note:- (5-3) - Hex. bolt M12 X 60 N IS:1364 - stainless steel with punched washer A-14 IS:2016

BARRAGE BAY GATE FOR BARRAGE
ACROSS RIVER BAITARANI OF
SAPTAMATRUKA PROJECT [LEFT
ARM]

Annexure - II

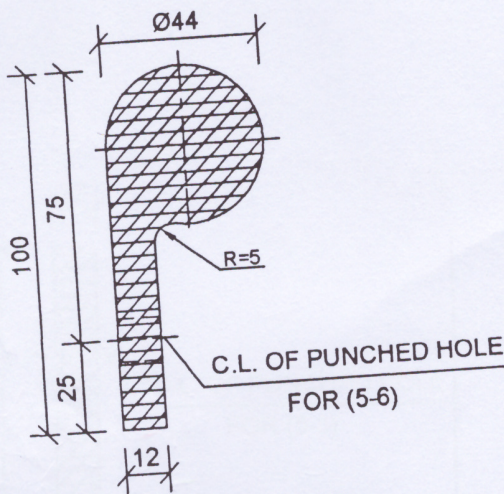

SIDE SEAL (5-4)

MATERIAL :- NATURAL OR SYNTHETIC RUBBER
CONFORMING TO IS:11855 - 1986
LENGTH OF EACH - 2655mm
NOS. REQD./GATE - 2 (TWO)

TOTAL QTY REQD. = 16 (SIXTEEN) NOS.

Note:- (5-6) - countersunk screw M12 X 70 N IS:
1365 - stainless steel with punched washer A-14
IS: 2016

[Signature]

BARRAGE BAY GATE FOR BARRAGE
ACROSS RIVER BAITARANI OF
SAPTAMATRUKA PROJECT [LEFT
ARM]