

ODISHA CONSTRUCTION CORPORATION LTD.
(A GOVT. OF ODISHA UNDERTAKING)
CENTRAL WORKSHOP, RASULGARH,
BHUBANESWAR-751010 (ODISHA)

TENDER DOCUMENT FOR
“SUPPLY OF RUBBER SEALS REQUIRED FOR DIFFERENT ONGOING PROJECTS”

The tender document comprises of the following:

1)	Tender call notice No.OCC/CWS/PROC/SMP-08/ 37 /2023-24 dated 16.10.2023	01 (One) sheet
2)	Terms and conditions	03 (Three) sheets
3)	Drawing	20 (Twenty) sheets
4)	Price schedule	03 (Three) sheets
		Total: 27 (Twenty seven) sheets

Signature of the tenderer or
His/their Power of attorney holder
with designation & seal.

Senior Manager (Mech.)-I
OCC Ltd, Central Workshop,
Rasulgarh, Bhubaneswar-10.

ODISHA CONSTRUCTION CORPORATION LTD.
(A GOVT. OF ODISHA UNDERTAKING)
CENTRAL WORKSHOP, RASULGARH,
BHUBANESWAR-751010 (ODISHA)

Tender Call Notice No. OCC/CWS/PROC/SMP-08/ 37 /23-24 Dtd.16.10.2023

Sealed tenders in conformity with the term & conditions, drawings and specifications in tender documents are invited from reputed manufacturers / authorized traders for **"SUPPLY OF RUBBER SEALS REQUIRED FOR DIFERENT ONGOING PROJECTS "** as per details below:

Cost of tender document (Non-refundable)	Sale of tender document		Earnest money deposit (EMD) required	Receipt of tender	Opening of Technical & price bid of tender
Rs. 2000/- GST @ 18% Rs.2360/- by hand or Rs.2460/- by Regd. Post/ courier	From 17.10.2023	To 02.11.2023 up to 1.00PM	1(One)% of the total quoted value including GST	Up to 3.30 P.M. on 02.11.2023	At 4.00 PM On 02.11.2023

The tender document can be purchased by the interested reputed manufacturers/ authorized traders by hand from the office of the undersigned on deposit of cost of tender document i.e. **Rs.2000/-** plus GST @ 18% amounting to **Rs.2360/-** in cash or in shape of A/c. payee demand draft drawn in favour of "Odisha Construction Corporation Limited- Project account" on any Nationalised Bank/ scheduled bank payable at Bhubaneswar (Non-refundable) and production of attested copies of the following documents and verification thereof by the undersigned. The tender document can also be obtained by the interested reputed manufacturers/ authorized traders by registered post/courier on sending the cost of tender document i.e. **Rs.2360/-** plus postage charges of **Rs.100/-** amounting to **Rs.2460/-** in shape of A/c. payee demand draft drawn as stated above and attested copies of the following documents and verification thereof by the undersigned. The undersigned will not be responsible for any kind of delay by the postal / courier authorities.

1. Valid GST Registration certificate.
2. PAN Card.
3. The bidders have to submit copies of purchase order, credentials, certificates etc. in support of supply of similar items of magnitude minimum amounting to 5.00 lakh in any one year of last 5 financial years (i.e, from financial year 2018-19 to 2022-23 including current financial year 23-24).
4. Tenderer should submit valid manufacturer / trader registration certificate.

The tender document can also be downloaded from our Website www.odishaconstruction.com or Govt. of Odisha website www.odishagov.nic.in to submit the tender (**Bidders are requested to visit our website regularly for any changes**). However, the cost of tender document i.e. **Rs.2000/-** plus GST @ 18% amounting to **Rs.2360/-** in cash or in shape of A/c payee demand draft as stated above in favour of "Odisha Construction Corporation Limited-Project Account" on any Nationalised Bank/ Scheduled Bank payable at Bhubaneswar (Non-refundable) along with attested photo copies of all above documents should be submitted while submitting the tender in Envelope-I. Otherwise, the tender will be cancelled & OCCL will not be responsible for missing of any page while downloading. If there will be a public holiday on the last date of sale of tender document and receipt & opening of the tender as specified above, the tender document will be sold and tender will be received & opened on the next working day at the same time and venue.

The SSI/NSIC/MSME units participating in tender are not entitled for exemption from payment of EMD/ Security Deposits/ Tender Paper costs as communicated vide DOWR Letter No. IIM-24/2018-14318/WR dated 24.05.2018 & Head Office, OCCL Letter No.5502/OCC/ CW-02/09(Vol-V)(WE) dated 30.05.2018.

The tenders will be opened in the presence of the tenderers or their authorized representatives, if they so desire. Tender through Fax/Telex/telegram/e-mail will not be accepted.

The undersigned reserves the right to accept or reject any or all tender without assigning any reason thereof.

Signature of the tenderer or
His/their Power of attorney holder
with designation & seal.

Senior Manager (Mech.)-I
OCC Ltd, Central Workshop,
Rasulgarh, Bhubaneswar-10.

ODISHA CONSTRUCTION CORPORATION LTD.
(A GOVT. OF ODISHA UNDERTAKING)
CENTRAL WORKSHOP, RASULGARH,
BHUBANESWAR-751010 (ODISHA)

TERMS AND CONDITIONS OF TENDER FOR
“SUPPLY OF RUBBER SEALS REQUIRED FOR DIFFERENT ONGOING PROJECTS”

1. Reputed manufacturers/ authorized traders having supplied similar items of similar magnitude earlier and satisfactorily accepted by the clients will be eligible to participate in the tender. The copies of purchase orders, credentials, certificates etc. in support of similar supply and satisfactory performance thereof will be furnished along with the tender.
2. Tender should be submitted in two bid system in two separate sealed covers and both will be submitted in a single sealed outer cover subscribing in bold letters as **“SUPPLY OF RUBBER SEALS REQUIRED FOR DIFFERENT ONGOING PROJECTS”** and also the date of opening of tender. The name and address of the tenderer should not be written on outer cover. Only the name and address of the purchaser should be written on the outer cover.
3. The tenderer should submit Earnest Money Deposit (EMD) @ 1(One)% of the total quoted value along with the tender in shape of A/C payee Demand Draft drawn in favour of “Odisha Construction Corporation Limited” - Project Account on any Nationalised Bank / Scheduled bank payable at Bhubaneswar. The tenders received without EMD will be out rightly rejected. EMD of the unsuccessful tenderers will be released only after finalization of the tender.
4.
 - i) The first envelope super scribing in bold letters as **“TECHNICAL BID”** should contain the following:
 - a. EMD of 1% as per clause- 3 above.
 - b. Attested copy of valid GST registration certificates. The tenderer will mention his GSTIN in his tender clearly without which the tender will not be taken into consideration.
 - c. Attested copy of PAN Card.
 - d. Attested copies of purchase orders, credentials, certificates in support of similar supply and magnitude and satisfactory performance thereof.
 - e. Complete tender document in original including terms and conditions but without detailed specifications and price schedule duly signed on each page by the tenderer or his power of attorney holder. In case of power of attorney holder, the attested copy of power of attorney should be furnished.
 - ii) Second envelope subscribing in bold letters **“SPECIFICATION AND PRICE SCHEDULE”** should contain detailed specifications and price schedule in original only duly filled in without leaving any column and line blank and signed on each page by the tenderer or his power of attorney holder.
5. The tender document can be purchased by the interested reputed manufacturers/ authorized traders by hand from the office of the undersigned from **17.10.2023 to 02.11.2023 (up to 1.00 PM)** during office hours on deposit of cost of tender document i.e. **Rs.2000/-** plus GST @ 18% amounting to **Rs.2360/-** in cash or in shape of A/c. payee demand draft drawn in favour of “Odisha Construction Corporation Limited-Project account” on any nationalized bank/ schedule bank payable at Bhubaneswar (non-refundable) and production of attested copies of the following documents and verification thereof by the undersigned. The tender document can also be obtained by the interested reputed manufacturers/ authorized traders by registered post / courier on sending the cost of tender document i.e. **Rs.2000/-** plus GST @ 18% plus postage charges of **Rs.100/-** amounting to **Rs.2460/-** in shape of A/c. Payee demand draft drawn in favour of “Odisha Construction Corporation Limited – Project account” on any nationalized bank/schedule bank payable at Bhubaneswar (non-refundable) and sending attested copies of the following documents and verification thereof by the undersigned.

Signature of the tenderer or
His/their Power of attorney holder
with designation & seal.

Senior Manager (Mech.)-I
OCC Ltd, Central Workshop,
Rasulgarh, Bhubaneswar-10.

1. Valid GST Registration certificate.
 2. PAN Card.
 3. The bidders have to submit copies of purchase order, credentials, certificates etc. in support of supply of similar items of magnitude minimum amounting to 5.00 lakh in any one year of last 5 financial years (i.e, from financial year 2018-19 to 2022-23 including current financial year 2023-24).
 4. Tenderer should submit valid manufacturer / trader registration certificate.
6. The tender document can also be downloaded from our Website www.odishaconstruction.com to submit the tender. However, the cost of tender document i.e. **Rs.2000/-** plus GST @ 18% amounting to **Rs.2360/-** in shape of A/c payee demand draft as stated above in favour of “Odisha Construction Corporation Limited- Project Account” on any Nationalised Bank/ Scheduled Bank payable at Bhubaneswar (Non-refundable) along with attested photo copies of all above documents should be submitted while submitting the tender in Envelope-I. Otherwise, the tender will be cancelled. OCCL will not be responsible for missing of any page while downloading. If there will be a public holiday on the last date of sale of tender document and receipt & opening of the tender as specified above, the tender document will be sold and tender will be received & opened on the next working day at the same time and venue.
7. The tenders will be received up to **3.30 PM** on **02.11.2023** and will be opened in the office of the undersigned on the same day at **4.00 PM** in presence of the tenderers or their authorized representatives, if they so desire.
8. The undersigned will not be responsible for any kind of delay by the postal/courier authorities.
9. The first envelope will be opened on **02.11.2023 4.00 PM** first. Then the documents in the first envelope submitted by the tenderers will be scrutinized preliminarily on the spot. The second envelope of the valid eligible tenders after preliminary scrutiny will be opened on the same day immediately subject to fulfilling the requirements mentioned in the tender.
10. Rubber seals shall be strictly as per IS: specification and size as mentioned in the drawing and price schedule format enclosed to the tender schedule.
11. Original test certificate of materials confirming to relevant IS: specification and grade for physical property will be provided by the successful tenderer from Govt./Govt. approved testing laboratory along with supply of materials. The purchaser is having the option to test the materials in any laboratory at the cost of the supplier and if the materials are not found in accordance with the BIS specifications and size, the materials will be rejected.
12. The materials shall be inspected at the time of receipt at OCCL store, Central Workshop, Rasulgarh, Bhubaneswar. If the materials are not found in accordance with proper IS specifications and drawings, the same shall be out rightly rejected.
13. The materials will be guaranteed by the supplier against any defect for a period of 18 months from the date of supply or 12 months from the date of use, whichever is earlier. Guarantee certificate in this regard will accompany with supply of materials. If any defect is found in the materials within the guarantee period, the same will have to be replaced free of cost by the supplier within a suitable time fixed by the purchaser.
14. The tenderer will quote their rates F.O.R. OCCL Store, Central Workshop, Rasulgarh, Bhubaneswar-10 (Odisha) indicating separately the basic price & packing, forwarding, transportation, transit insurance, handling charges & taxes, duties, levies etc. strictly in the detailed specifications and price schedule format in original. All columns and lines of the price schedule should be filled in properly without leaving any thing blank. The details and rates of duties and taxes should be indicated clearly in the price schedule. **After finalization of tender, the quantity of rubber seals to be ordered may increase /decrease as per decision of the purchaser.**
15. The tenderer should quote appropriate taxes with the offer.

Signature of the tenderer or
His/their Power of attorney holder
with designation & seal.

Senior Manager (Mech.)-I
OCC Ltd, Central Workshop,
Rasulgarh, Bhubaneswar-10.

16. 90% payment will be made within 30 (Thirty) days of receipt, verification and acceptance of the complete materials along with bill, test certificate, guarantee certificate and other documents. Balance 10% will be released after 18 months of supply or 12 months from the date of commissioning whichever is earlier. However if a performance bank guarantee is received for 10% of the total basic cost, the same will be released within 60 days from the date of receipt of materials.
17. Price escalation will not be allowed under any circumstances. The quoted rates will remain firm till execution of the work order.
18. The validity of the offer should be for a period of 120 (One hundred twenty) days from the date of opening of the tender.
19. The complete ordered quantity is to be supplied within 60 (Sixty) days from the date of issue of the purchase order, failing which the order is liable for cancellation without assigning any reason thereof by the purchaser. In case of cancellation of the order the EMD will be forfeited. In case of any delay in supply of materials beyond the delivery schedule, supplier shall be liable to pay L.D. @ 0.5% (Half percent) of the total ordered value per week of delay or part thereof subject to maximum of 5% (Five percent) of the total ordered value. Thereafter, the order may be cancelled with the discretion of purchaser.
20. Conditional offers with deviations will not be accepted. Those, who do not agree to the terms and conditions regarding payments, delivery and others, need not quote.
21. The authority reserves the right to accept/reject any or all quotations without assigning any reason thereof.
22. Tender through fax/telex/telegram/e-mail will not be accepted.
23. Any dispute arising out of this tender or order thereof is to be settled in proper court under the jurisdiction of Odisha High Court at Cuttack or courts under the jurisdiction of Odisha High Court at Bhubaneswar only.

Signature of the tenderer or
His/their Power of attorney holder
with designation & seal.

Senior Manager (Mech.)-I
OCC Ltd, Central Workshop,
Rasulgarh, Bhubaneswar-10.

ODISHA CONSTRUCTION CORPORATION LIMITED
(A GOVT. OF ODISHA UNDERTAKING)
CENTRAL WORKSHOP, RASULGARH, BHUBANESWAR-751010 (ODISHA)

DETAILED SPECIFICATION AND PRICE SCHEDULE FOR
"SUPPLY OF RUBBER SEALS REQUIRED FOR KANUPUR IRRIGATION PROJECT" VIDE TCN No.OCC/CWS/PROC/SMP-08 / 37 /2023-24 DATED.16.10.2023 DUE
DATE OF OPENING ON DATED 02.11.2023

Sl. No.	Description of Item	Part No.	Unit	Qty.	Rate per unit in Rs.					Total amount in Rs. for full materials	
					Basic Price per unit	P & F, transportation, transit insurance etc.	GST as applicable	Total in figures	Total in words	In figure	In words

RADIAL GATE OF GHATAKESWAR MULTIPURPOSE PROJECT

1	BOTTOM SEAL - 9860MM LONG-AS PER DRAWING (NATURAL OR SYNTHETIC RUBBER CONFORMING TO IS:11855) (As per drawing in Annexure-I)	5-1	Nos.	3								
2	SIDE SEAL - 7082MM LONG MEASURED ALONG R = 7812MM (CUT TO SHAPE)-AS PER DRAWING(NATURAL OR SYNTHETIC RUBBER CONFORMING TO IS:11855) (As per drawing in Annexure-II)	5-3	Nos.	6								
3	TRUNNION SEAL-AS PER DRAWING (NYLON REINFORCED RUBBER) (As per drawing in Annexure-III)	10-12	Nos.	12								

SERVICE GATE FOR HR CUM DEPLETION SLUICE OF GHATAKESWAR MULTIPURPOSE PROJECT.

4	BOTTOM SEAL - 1506 LONG (AS SHOWN)NATURAL OR SYNTHETIC RUBBER CONFORMING TO IS:11855 (As per drawing in Annexure-IV)	4-1	Nos.	1								
5	SIDE SEAL - 543 LONG (FLUROCARBON CLADDED NATURAL OR SYNTHETIC RUBBER CONFORMING TO IS:11855) (As per drawing in Annexure-V)	4-4	Nos.	2								
6	TOP SEAL - 1026 LONG (FLUROCARBON CLADDED NATURAL OR SYNTHETIC RUBBER CONFORMING TO IS:11855)(As per drawing in Annexure-V)	4-7	Nos.	1								
7	240 X 240 CORNER SEAL (1L & 1R) (FLUROCARBON CLADDED NATURAL OR SYNTHETIC RUBBER CONFORMING TO IS:11855) (As per drawing in Annexure-VI)	4-9	Nos.	2								
8	SPRING LOADED DOUBLE LIP BUILT UP OIL SEAL OD - 72, 8 WIDTH FOR SHAFT DIA - 55.	5-2	Nos.	8								
9	Ø4mm RUBBER "O" RING OD - 104mm, ID - 100mm	5-6	Nos.	8								

Signature of the tenderer or his/their
power of attorney holder
with designation & seal.

Senior Manager (Mech.)-I
OCC Ltd, Central Workshop,
Rasulgarh, Bhubaneswar-751010

Sl. No.	Description of Item	Part No.	Unit	Qty.	Rate per unit in Rs.					Total amount in Rs. for full materials	
					Basic Price per unit	P & F, transportation, transit insurance etc.	GST as applicable	Total in figures	Total in words	In figure	In words

EMERGENCY GATE FOR HR CUM DEPLETION SLUICE OF GHATAKESWAR MULTIPURPOSE PROJECT.

10	BOTTOM SEAL - 1294MM LONG OF NATURAL OR SYNTHETIC RUBBER CONFORMING TO IS:11855 (As per drawing in Annexure-VII)	4-1	Nos.	1							
11	SIDE SEAL - 547MM LONG OF FLUOROCARBON CLADDED NATURAL OR SYNTHETIC RUBBER CONFORMING TO IS:11855 (As per drawing in Annexure-VIII)	4-4	Nos.	2							
12	TOP SEAL - 1034MM LONG OF FLUOROCARBON CLADDED NATURAL OR SYNTHETIC RUBBER CONFORMING TO IS:11855 (As per drawing in Annexure-VIII)	4-7	Nos.	1							
13	180MM X 180MM CORNER SEAL (1L & 1R) OF FLUOROCARBON CLADDED NATURAL OR SYNTHETIC RUBBER CONFORMING TO IS:11855 (As per drawing in Annexure-IX)	4-9	Nos.	2							
14	SPRING LOADED DOUBLE LIP BUILT UP OIL SEAL OD - 72, 8 WIDTH FOR SHAFT DIA - 55.	5-2	Nos.	8							
15	Ø4mm RUBBER "O" RING OD - 108mm, ID - 100mm	5-6	Nos.	8							

SUPPLY OF RUBBER SEAL FOR UNDER SLUICE GATE ,BARRAGE BAY GATE OF SAPTAMATRUKA BARRAGE PROJECT(RIGHT ARM).

16	Bottom seal-8306mm long of Natural or synthetic rubber confirming to IS:11855-1986 (As per drawing in Annexure-X)	5-1	Nos.	8							
17	Side seal-3355mm long of natural or synthetic rubber confirming to IS:11855-1986 (As per drawing in Annexure-XI)	5-4	Nos.	4							
18	Side seal-2855mm long of natural or synthetic rubber confirming to IS:11855-1986 (As per drawing in Annexure-XII)	5-4	Nos.	12							
19	Spring loaded double leaf built up oil seal OD-100,15 width for shaft dia -70(Std.)	6-2	Nos.	48							
20	Ø3mm rubber "O" ring ID-125mm,OD-131mm(Std.)	6-6	Nos.	48							
21	Spring loaded double leaf built up oil seal OD-105mm,15mm width for shaft dia -75mm(Std.)	6-2	Nos.	16							
22	Ø3mm rubber "O" ring ID-130mm,OD-136mm(Std.)	6-6	Nos.	16							

Signature of the tenderer or his/their
power of attorney holder
with designation & seal.

Senior Manager (Mech.)-I
OCC Ltd, Central Workshop,
Rasulgarh, Bhubaneswar-751010

Sl. No.	Description of Item	Part No.	Unit	Qty.	Rate per unit in Rs.					Total amount in Rs. for full materials	
					Basic Price per unit	P & F, transportation, transit insurance etc.	GST as applicable	Total in figures	Total in words	In figure	In words

SUPPLY OF RUBBER SEAL FOR STOPLOG FOR UNDER SLUICE GATE ,BARRAGE BAY GATE OF SAPTAMATRUKA BARRAGE PROJECT(RIGHT ARM).

23	SIDE SEAL - 1041MM LONG(NATURAL OR SYNTHETIC RUBBER CONFORMING TO IS:11855-1986) (As per drawing in Annexure-XIII)	4-1	Nos.	8							
24	BOTTOM SEAL - 8104MM LONG(NATURAL OR SYNTHETIC RUBBER CONFORMING TO IS:11855-1986) (As per drawing in Annexure-XIV)	4-4	Nos.	4							

SUPPLY OF RUBBER SEAL FOR 4000mm X 3035mm ESCAPE GATE AT RD.15640M of DARPANI BRANCH CANAL OF RENGALI RIGHT IRRIGATION PROJECT.

25	Bottom seal-4210mm long of synthetic rubber conforming to IS:11855 (As per drawing in Annexure-XV)	4-1	Nos.	2							
26	Side seal-2940mm long of synthetic rubber conforming to IS:11855 (As per drawing in Annexure-XVI)	4-4	Nos.	4							
27	Top seal-3750mm long of synthetic rubber conforming to IS:11855 (As per drawing in Annexure-XVII)	4-7	Nos.	2							
28	Corner seal (1L & 1R) 260 LONG synthetic rubber conforming to IS:11855 - (As per drawing in Annexure-XVIII)	4-9	Nos.	4							

SUPPLY OF RUBBER SEAL FOR 4000mm X 2935mm CROSS REGULATOR GATE AT RD.15640M of DARPANI BRANCH CANAL OF RENGALI RIGHT IRRIGATION PROJECT

29	Bottom seal-4314mm long of Natural or synthetic rubber conforming to IS:11855-1986 (As per drawing in Annexure-XIX)	4-1	Nos.	4							
30	Side seal-2990mm long of natural or synthetic rubber conforming to IS:11855-1986 (As per drawing in Annexure-XX)	4-4	Nos.	8							

Signature of the tenderer or his/their
power of attorney holder
with designation & seal.

Senior Manager (Mech.)-I
OCC Ltd, Central Workshop,
Rasulgarh, Bhubaneswar-751010

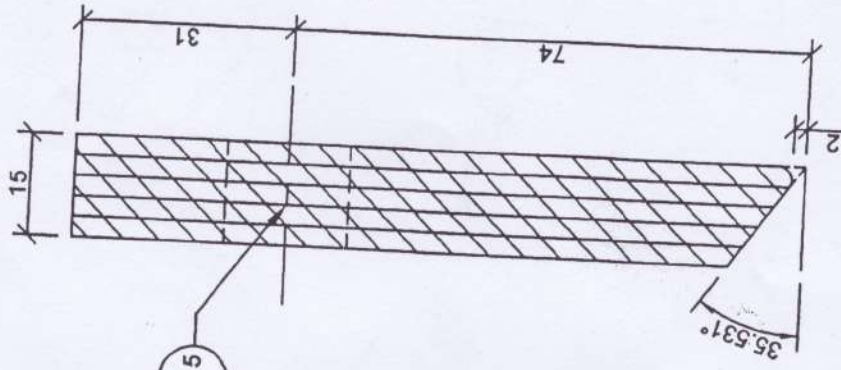

Annexure - I

[Handwritten signature]

RADIAL GATE FOR SPILLWAY OF
GHATAKESWAR MULTIPURPOSE PROJECT
OCCL.

BOTTOM SEAL (5-1)

MATERIAL - NATURAL OR SYNTHETIC RUBBER
CONFORMING TO IS:11855

LENGTH OF EACH = 9860 mm

TOTAL QTY = 03 (THREE) NOS.

Note: (S-5) - Hex. bolt M16X70 N IS:1364 SS. with spring washers.

Annexure - II

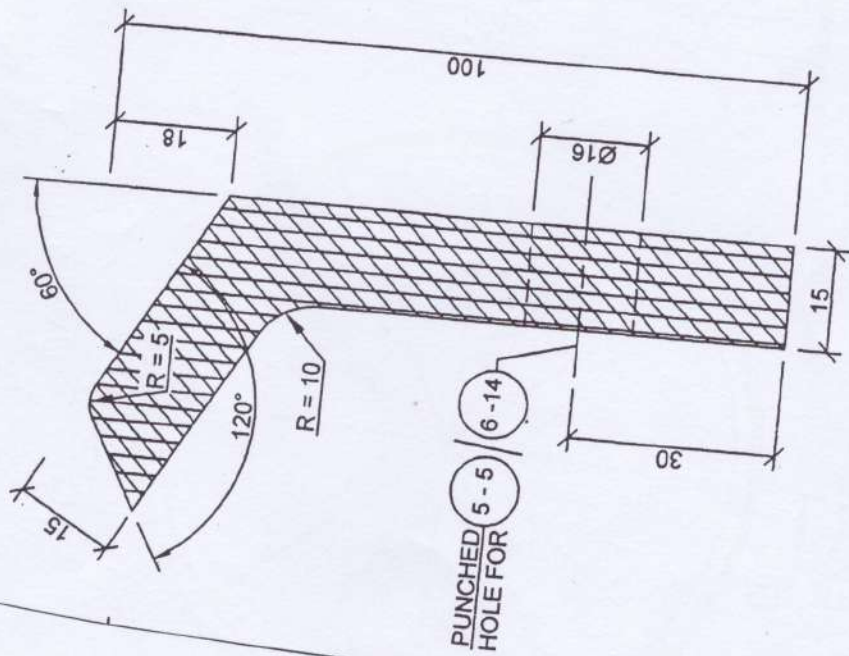

SIDE SEAL (5-3)

MATERIAL - NATURAL OR SYNTHETIC RUBBER
CONFORMING TO IS:11855

LENGTH OF EACH = 7082 mm

TOTAL QTY = 06 (SIX) NOS.

Note :- (5-5) - Hex bolt M16 X 70 N IS: 1364 S.S. with spring washer
(6-14) - Hex screw M16 X 50 N IS: 1364 with washer.

RADIAL GATE FOR SPILLWAY OF
GHATAKESWAR MULTIPURPOSE
PROJECT.
OCCL.

Handwritten signature

Annexure-III

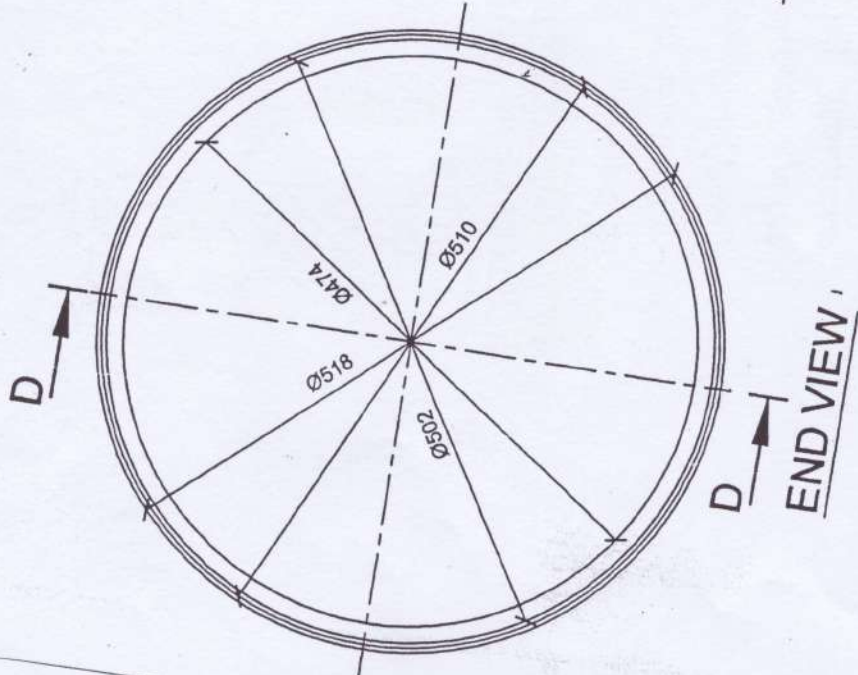

SEE DETAIL - "X"

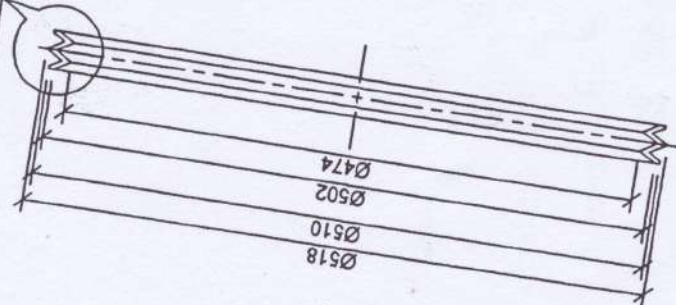

SECTION - DD

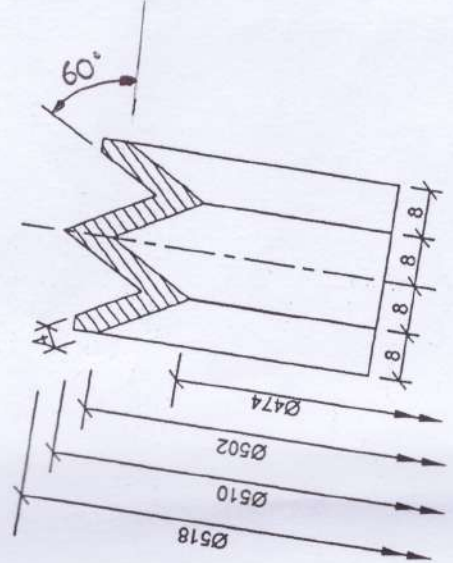

DETAIL - "X"

TRUNNION SEAL ¹⁰⁻¹²
MATERIAL : NYLON REINFORCED RUBBER

TOTAL QTY. = 12 (TWELVE) NOS.

RADIAL GATE FOR SPILLWAY
OF GHATAKESWAR MULTIPURPOSE
PROJECT.
OCCL.

Annealed-IV

[Handwritten signature]

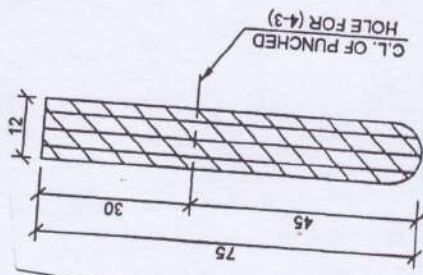

BOTTOM SEAL

MATERIAL:- NATURAL OR SYNTHETIC RUBBER CONFORMING TO IS:11855 NOS. RECD./GATE-1 LENGTH:- 1506 mm

TOTAL QTY. = 01 (ONE) NOS.

Note:- (4-3) - Hex. head bolt IS: 1364 (part-1)
M16 X 70N - stainless steel with punchrod
washer A18 IS:2016

SERVICE GATE FOR HEAD
REGULATOR CUM DEPLETION SLVICE
OF GHATAKESWAR MULTIPURPOSE
PROJECT.
OCCL.

Annexure - (A)

[Handwritten signature]

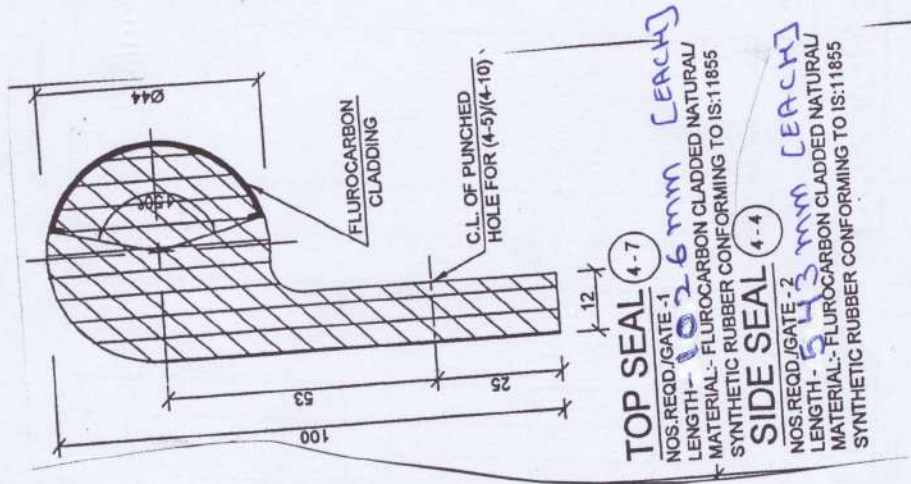

SERVICE GATE FOR HEAD REGULATOR
 COM DEPLETION SLUCE OF GHATAKOP
 MULTI PURPOSE PROJECT.
 OCCL.

TOTAL QTY. FOR TOP SEAL = 01 (ONE) NOS.
 TOTAL QTY. FOR SIDE SEAL = 02 (TWO) NOS.

Note :- (4-5) - Slotted roundssunk screws M12 X 80 N IS: 1365 - stainless steel with punched washer A14 IS: 2016
 (4-10) - Slotted roundssunk screws M12 X 90 N IS: 1365 - stainless steel with slotted/punched washer.

Annexure-VI

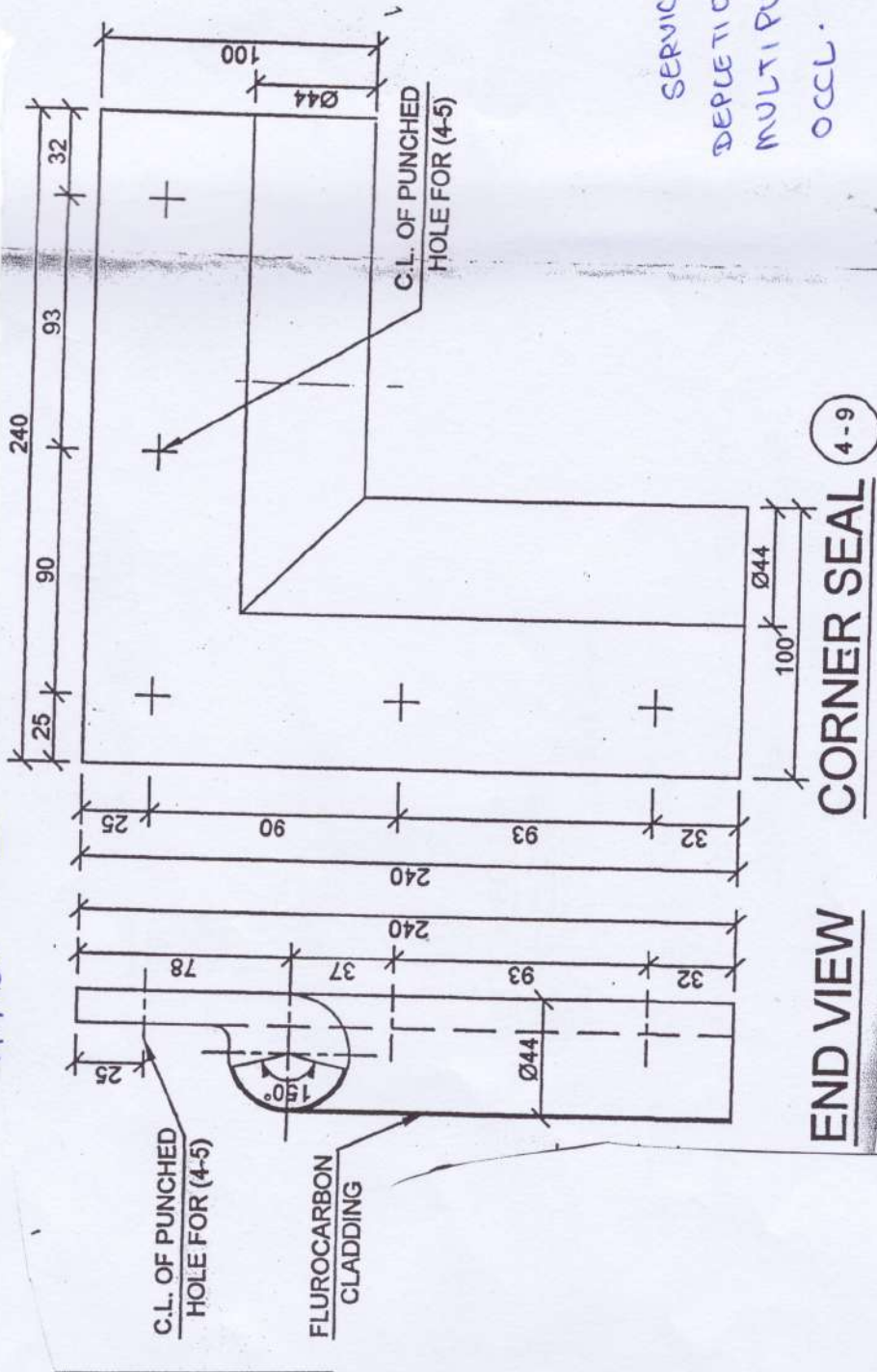

END VIEW **CORNER SEAL** (4-9)

MATERIAL - FLUROCARBON CLADED NATURAL OR SYNTHETIC RUBBER CONFORMING TO IS: 11855

NOS. REQD (GATE = 2 (LEFT & 1 RIGHT))

TOTAL QTY = 02 (TWO) NOS.

Note: - (4-5) - slotted countersink screw M12 x 80N IS: 1365 - stainless steel with punched washer A14 IS: 2016.

[Handwritten signature]

SERVICE GATE FOR HR COM DEPLETION SVICICE OF GHATAKESWAR MULTIPURPOSE PROJECT. OCCL.

Anneure - CVII

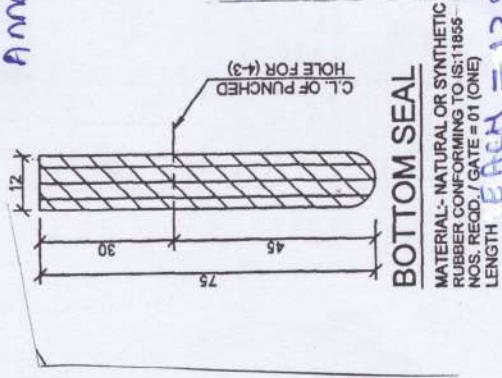

TOTAL QTY. = 01 (ONE) NOS.

Note:- (4-3) - Hex head bolt. IS: 1364 (Part-1) M16 X 70N - stainless steel with punched washer A-18 IS: 2016.

[Handwritten signature]

EMERGENCY GATE FOR HR COM
DEPLETION SLICE OF GHATAKESWAR
MULTIPURPOSE PROJECT.
OCCL.

Annexure - VIII

Handwritten signature

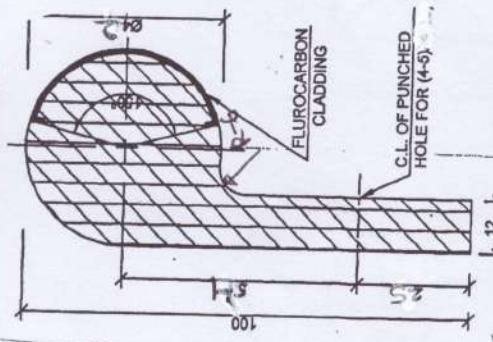

TOP SEAL (4-7)

NOS. REQD. / GATE = 01 (ONE)
LENGTH = 1034 mm
MATERIAL: FLUOROCARBON CLADDED NATURAL SYNTHETIC RUBBER CONFORMING TO IS:11855

SIDE SEAL (4-4)

NOS. REQD. / GATE = 02 (TWO)
LENGTH = 547 mm
MATERIAL: FLUOROCARBON CLADDED NATURAL SYNTHETIC RUBBER CONFORMING TO IS:11855

TOTAL QTY. OF TOP SEAL = 01 (ONE) NOS.
TOTAL QTY. OF SIDE SEAL = 02 (TWO) NOS.

Note:- (4-5) - slotted countersunk screw M12 X 80 N IS: 1365 - stainless steel with punched washer A-14 IS: 2016.

EMERGENCY GATE FOR HR COM
DEPLETION SLICE OF GHATAKESWAR
MULTIPURPOSE PROJECT,
OCCL.

Annexure - IX

[Handwritten signature]

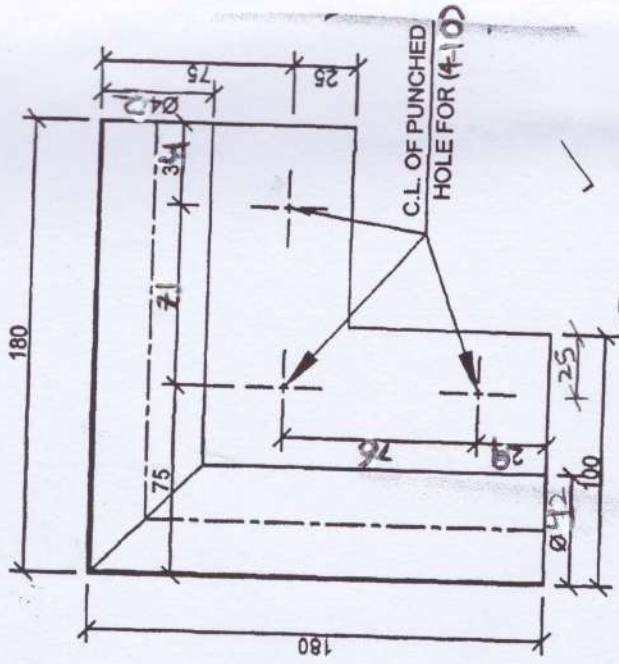

CORNER SEAL (4-9)

MATERIAL - FLUOROCARBON CLADDED NATURAL OR SYNTHETIC RUBBER CONFORMING TO IS:11855 NOS. REQD. / GATE = 02 (1 LEFT & 1 RIGHT)

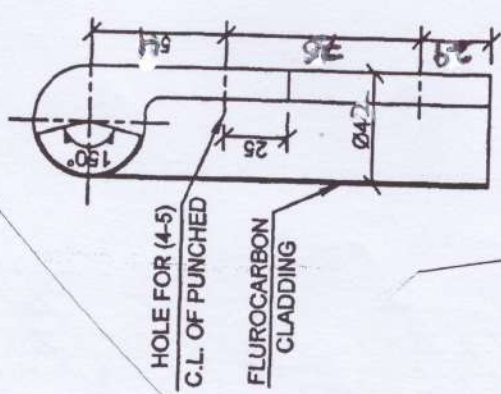

END VIEW

TOTAL QTY = 02 (Two) NOS.

Note:- (4-10) - Slotted countersunk screw M12 X 90N IS: 1365 - stainless steel with punched washer / paper washer
 (4-5) - Slotted countersunk screw M12 X 80N IS: 1365 - S.S. with punched washer
 EMERGENCY GATE FOR HEAD REGULATOR
 CUM DEPLETION SLICE OF
 GHATAKESWAR MULTIPURPOSE PROJECT
 O.C.C.L.

Annexure - X

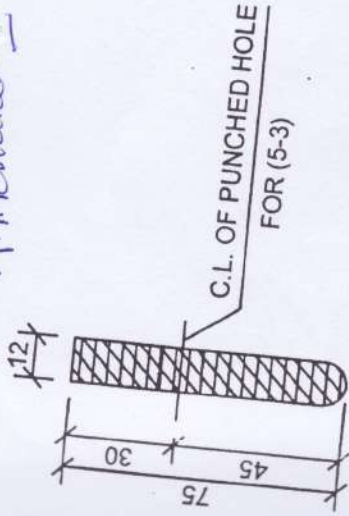

BOTTOM SEAL (5-1)

MATERIAL :- NATURAL OR SYNTHETIC RUBBER
CONFORMING TO IS:11855 - 1986
LENGTH OF EACH - 8306 mm
NOS. REQD./GATE - 1 (ONE)

TOTAL QTY = 08 (EIGHT) NOS.

Note:- (5-3) - Nec. bolt M12 x 60N IS:
136H - stainless steel with punched
washer A-14 IS: 2016.

UNDER SLUICE GATE & BARRAGE BAY GATE
FOR BARRAGE (ISS) ACROSS RIVER BAITARAMI
RIGHT ARM NEAR JAJPUR TOWN AT
SAPTA MATRAKA TEMPLE
OCCL

Annexure - XI

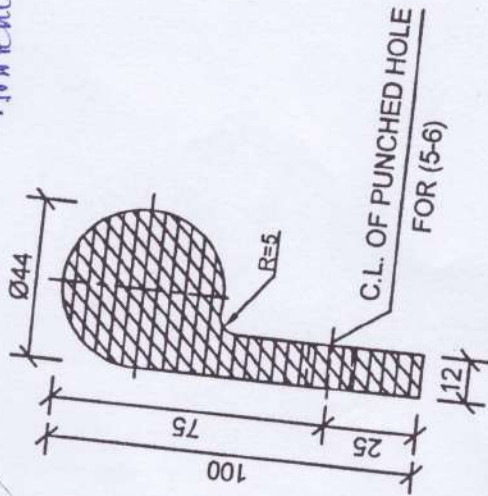

SIDE SEAL (5-4)

MATERIAL :- NATURAL OR SYNTHETIC RUBBER
CONFORMING TO IS: 11855 - 1986
LENGTH OF EACH - 3355 mm
NOS. REQD./GATE - 2 (TWO)

Handwritten signature

TOTAL QTY = 04 (FOUR) NOS.

Note :- (5-6) - Countersunk screw M12 X 70 N IS: 1365 - stainless steel with punched washer A-14 IS: 2016

UNDERSLUICE GATE FOR BARRAGE (ISS) ACROSS RIVER BAITARANI
RIGHT ARM NEAR SATPUR TOWN AT SAPTAMATRUKA TEMPLE.
OCCL.

Annexure - XII

[Handwritten signature]

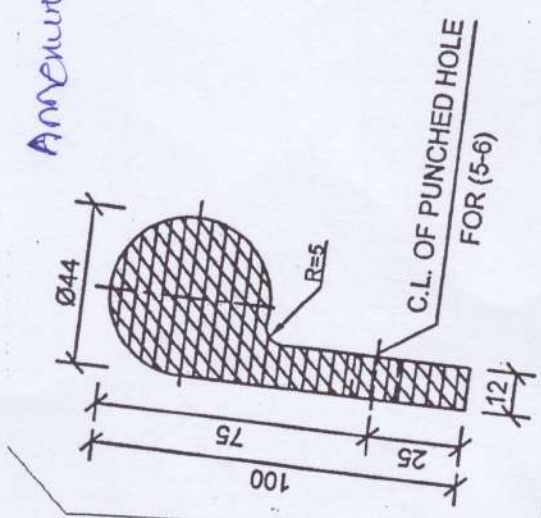

SIDE SEAL (5-4)

MATERIAL :- NATURAL OR SYNTHETIC RUBBER
CONFORMING TO IS:11855 - 1986
LENGTH OF EACH - 2855 mm
NOS. REQD./GATE - 2 (TWO)

TOTAL QTY = 12 (TWELVE) NOS.

Note: (5-6) Counter sunk screw M12 X 70 N IS: 1365 - stainless steel with punched washer A-14 IS: 2016

BARRAGE BAY GATE FOR BARRAGE (ISS) ACROSS RIVER BAITARANI
RIGHT ARM NEAR JAJPUR TOWN AT SAPTAMATRUKA TEMPLE
OCCL

Annexure - XIII

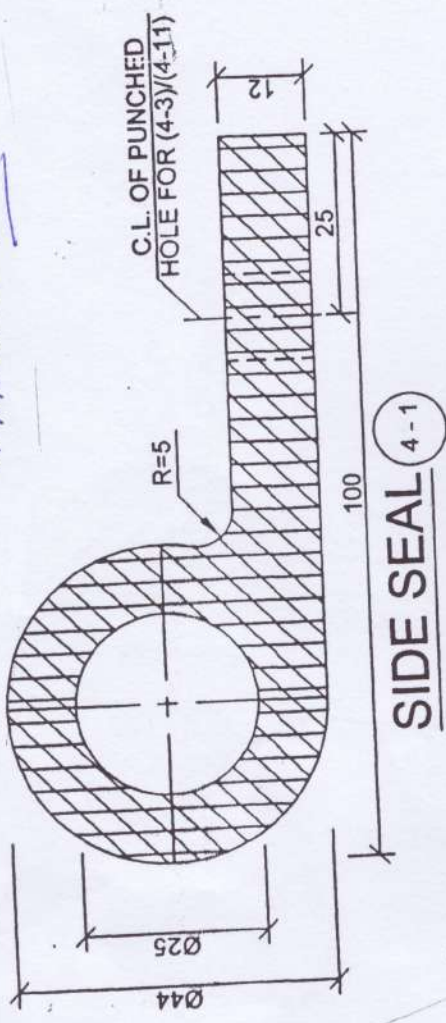

Signature

SIDE SEAL (4-1)

MATL. - NATURAL OR SYNTHETIC RUBBER CONFORMING TO IS: 1855-1986

LENGTH OF EACH = 1041 mm

TOTAL QTY = 08 (EIGHT) NOS.

Note :- (4-3) - countersunk screw M12 X 70 N IS: 1365 - S.S. with washer.

(4-11) - countersunk screw M12 X 80 N IS: 1365 - S.S. with washer.

STORLOG FOR BARRAGE BAY AND UNDER SLUICE GATES OF BARRAGE (ISS) ACROSS RIVER BAITARANI RIGHT ARM NEAR JASPUR TOWN AT SARTAMATRUKA TEMPLE. OCCL.

Annexure - XIV

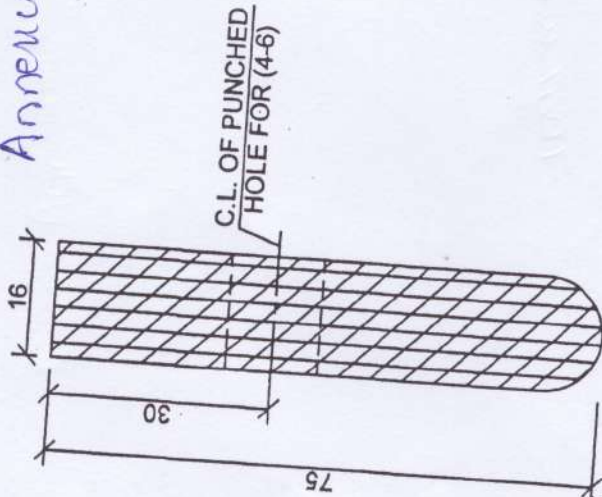

BOTTOM SEAL (4-4)
MATL. - NATURAL OR SYNTHETIC
RUBBER CONFORMING TO IS:1855-1986

LENGTH EACH = 8104 mm

TOTAL QTY = 04 (FOUR) NOS.

Note :- (4-6) - Hex. bolt M12x60 N - IS: 1363 - S.S. with washer.

STOPLOG FOR BARRAGE BAY & UNDERSLUICE GATES OF BARRAGE (ISS) ACROSS RIVER BAITARANI RIGHT ARM NEAR JASRUR TOWN AT SAPTAMATRUKA TEMPLE.

DECL.

[Handwritten signature]

Annexure - 22

[Handwritten signature]

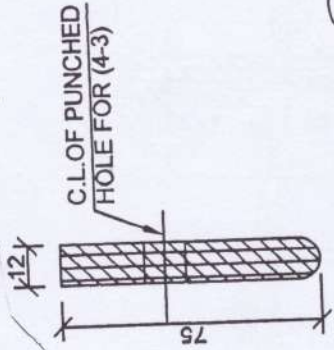

BOTTOM SEAL (4-1)

NOS. REQD/GATE - 1
LENGTH - 75 mm
MATL. - SYNTHETIC RUBBER
CONFORMING TO IS:11855

TOTAL QTY = 02 (TWO) NOS.

Note:- (4-3) - Hex head bolt - IS:1363 (Part-1) / ISO 4016
M12 X 60N with punched washer A-13 IS: 2016.

ESCAPE GATE AT DARRANI BRANCH
CANAL OF RENGALI RIGHT IRR. PROSEC
OCCL.

Annexure - 20VI

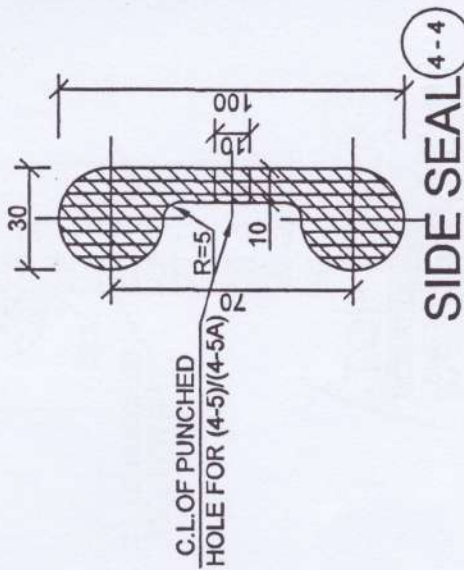

NOS. REQD/GATE - 2
LENGTH - 2940 mm
MATL. - SYNTHETIC RUBBER
CONFORMING TO IS:11855

TOTAL QTY. = 04 (FOUR) NOS.

Note :- (4-5)/(4-5A) - counter sunk screw M10X80
IS: 1365 - 4.8

ESCAPE GATE AT DARRANI BRANCH
CANAL OF RENGALI RIGHT IRR.
PROJECT. OCCL.

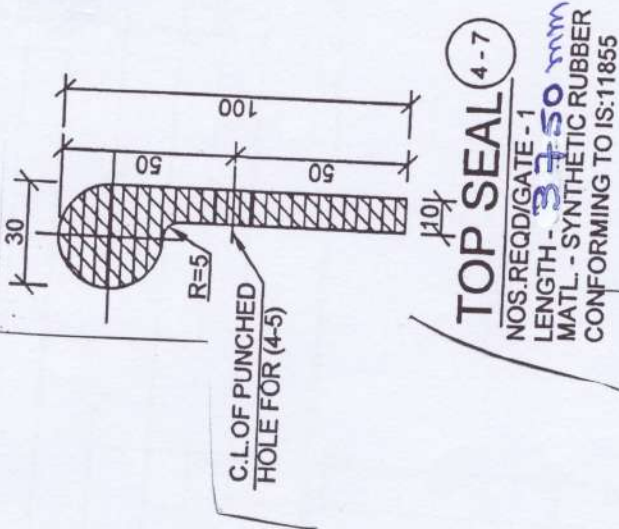

[Handwritten signature]

Annexure - XVII

TOTAL QTY = 02 (Two) NOS.

Note :- (4-5) - countersunk screw M10 X 70 IS: 1365 - 4.8

ESCAPE GATE OF BARRANI BRANCH
 CANAL OF RENGALI RIGHT IRR.
 PROJECT.
 OCCL.

ESCAPE GATE AT DARPANI
 BRANCH CANAL OF
 BENGALI RIGHT IRRIGATION
 PROJECT. OCCL.

Annexure - VIII

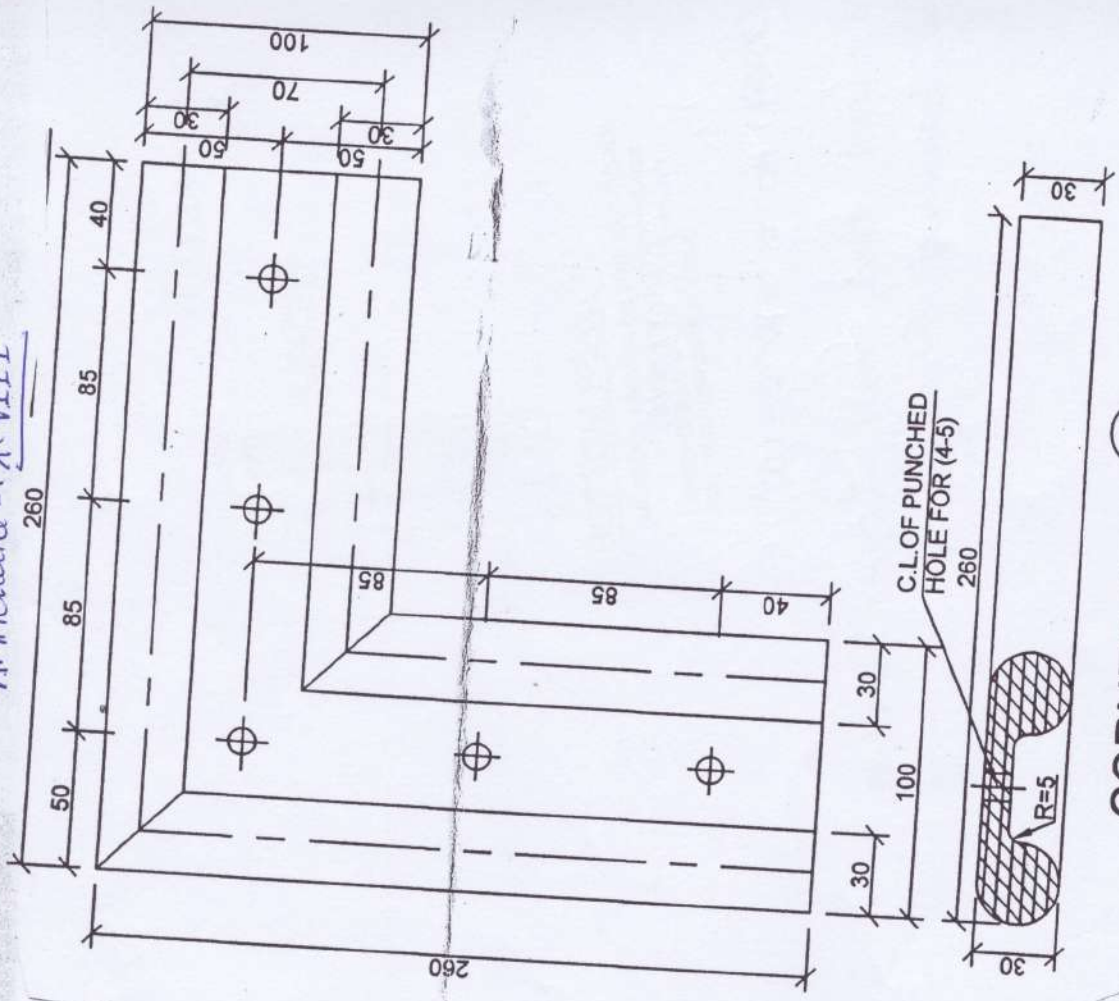

CORNER SEAL 4-9

NOS. REQD/GATE - 2
 LENGTH - 260mm / 260mm
 MATL - SYNTHETIC RUBBER
 CONFORMING TO IS-11855

[Handwritten signature]

TOTAL QTY = 04 (FOUR) NOS.

Note :- (4-5) - Counter Bunkr screw M10 x 70 IS: 1365 - 4.8

Annexure - AIX

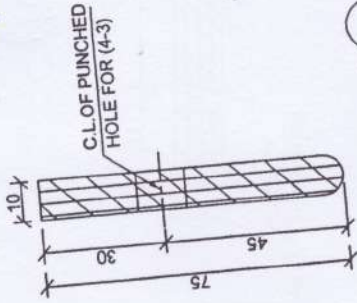

BOTTOM SEAL (4-1)

MATERIAL :- NATURAL OR SYNTHETIC RUBBER
CONFORMING TO IS:11855-1986

LENGTH OF SEAL = 75 mm

NOS. REQD. PER GATE = 01 (ONE)

TOTAL QTY = 04 (FOUR) NOS-

Note:- (4-3) - Hex. bolt M12 X 60 N IS: 1364 - stainless steel
with punched washer A-14 IS: 2016.

[Handwritten signature]

CROSS REGULATOR GATE OF
DAR PANI BRANCH CANAL.
OCCL-

Annexure - 22

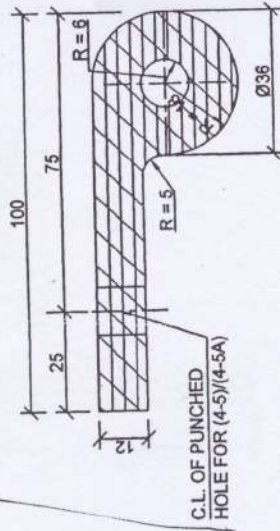

[Handwritten signature]

SIDE SEAL (4-4)

MATERIAL :- NATURAL OR SYNTHETIC RUBBER
CONFORMING TO IS:11855-1986
LENGTH OF EACH SEAL = 2990 mm
NOS. REQD. PER GATE = 02 (TWO)

TOTAL QTY = 08 (EIGHT) NOS.

Note :- (4-5) - slopped C.S. & screw M12 X 70N IS:1365 S'S.

CROSS REGULATOR GATE OF DARRANI
BRANCH CANAL.
OCCL.