

**ODISHA CONSTRUCTION CORPORATION LTD.**  
(A GOVT. OF ODISHA UNDERTAKING)  
**CENTRAL WORKSHOP,RASULGARH,**  
BHUBANESWAR-751010 (ODISHA)

**TENDER DOCUMENT FOR**  
“LABOUR CHARGES TOWARDS THREAD CUTTING ON SCREW ROD AND COUPLER NUT FOR LOWER  
SUKTEL IRRIGAION PROJECT”

The tender document comprises of the following:

1)	Tender call notice No.OCC/CWS/PROC/OFF-3/ 22 dated 03.06.2023	01 (One) sheet
2)	Scope of Work	01(One) sheet
3)	Terms and conditions	01 (One) sheet
4)	Price schedule	01 (One) sheet
5)	Drawing	01(One) sheet

-----  
Total 5 (Five) sheets  
-----

Signature of the Tenderer or his/their  
power of attorney holder  
with designation & seal.

Senior Manager (Mech.)-I  
OCC Ltd, Central Workshop,  
Rasulgarh, Bhubaneswar-751010

**ODISHA CONSTRUCTION CORPORATION LIMITED**  
**(A GOVT. OF ODISHA UNDERTAKING)**  
**CENTRAL WORKSHOP:RASULGARH, BHUBANESWAR-751010**

**TENDER CALL NOTICE No. OCC/CWS/PROC/OFF-3/22/2023-24 Dated 03.06.2023**

Sealed tenders are invited from reputed workshop owner/ SSI / NSIC / MSME Units from the Cuttack and Khordha districts of Odisha having facility to do the thread cutting on screw rod and coupler nut for Lower Suktel Irrigation Project at their workshop. Rate should be quoted as per detailed specification enclosed.

Cost of tender document (Non-refundable)	Sale of tender Document		Receipt of tender	Opening of tender
<b>Rs.600/- plus GST @ 18% Rs.708/-</b> by hand & <b>Rs.808/-</b> by Regd. Post/ courier.	From <b>03.06.2023</b>	To <b>08.06.2023</b> up to <b>01.00 PM</b>	Up to <b>03.30 PM</b> on <b>08.06.2023</b>	At <b>04.00 PM</b> on <b>08.06.2023</b>

The tender shall accompany with Valid GST registration certificate & PAN Card. The rates quoted shall be made for worksite of the Supplier. The Tender is to be duly sealed in closed covers and superscribed as **"TENDER FOR LABOUR CHARGES TOWARDS THREAD CUTTING ON SCREW ROD AND COUPLER NUT FOR LOWER SUKTEL IRRIGATION PROJECT"** due on **08.06.2023** to be addressed to the undersigned.

1. The tender document may be purchased from the office of the Senior Manager (Mech.)-I, Odisha Construction Corporation Ltd., Central Workshop, Rasulgarh, Bhubaneswar-751010 during office hours from **03.06.2023** to **08.06.2023** up to **1.00 PM** of **08.06.2023** on payment of non-refundable cost of Tender document as indicated in the table above in shape of Cash/Demand Draft drawn on any nationalized/scheduled bank payable at Bhubaneswar only in favour of M/s Odisha Construction Corporation Ltd.-Project Account. Interested Tenderers may obtain further information, if any, from the undersigned.
2. The tender document may be downloaded from OCCL website [www.odishaconstruction.com](http://www.odishaconstruction.com) and non-refundable cost of Tender document amounting to **Rs.708/-** (Rupees seven hundred eight) only inclusive of GST @ 18% in shape of Account Payee Demand Draft drawn on any nationalized/scheduled bank payable at Bhubaneswar only in favour of M/s Odisha Construction Corporation Ltd.-Project Account may be deposited along with the Tender.
3. The tenders must be submitted to the Senior Manager(Mech.)-I, Odisha Construction Corporation Ltd., Central Workshop, Rasulgarh, Bhubaneswar-751010 (Odisha) on or before **3.30PM** on **08.06.2023** and will be opened on **08.06.2023** at **4.00 PM** in the presence of the Tenderers, who may like to be present. If there will be a public holiday on the last date of sale of Tender document and receipt & opening of the Tenders as specified above, the Tender document will be sold and Tenders will be received & opened on the next working day at the same time and venue.

**The SSI/NSIC/MSME units participating in tender are not entitled for exemption from payment of EMD/ Security Deposits/ Tender Paper costs as communicated vide DOWR Letter No. IIM-24/2018-14318/WR dated 24.05.2018 & Head Office, OCCL Letter No.5502/OCC/ CW-02/09(Vol-V)(WE) dated 30.05.2018.**

The tenders will be opened in the presence of the tenderers or their authorised representatives. Tender through Fax/Telex/telegram/e-mail will not be accepted

The undersigned reserves the right to accept or reject any or all tenders without assigning any reason thereof.

Signature of the Tenderer or his/their  
power of attorney holder  
with designation & seal.

Senior Manager (Mech.)-I  
OCC Ltd, Central Workshop,  
Rasulgarh, Bhubaneswar-751010

## **SCOPE OF WORK.**

Scope of work under this Tender to be executed by the successful bidder are as under.

There are screw rod and coupler nut on which thread cutting work to be done to match with the screw & Nut..

### **Scope of OCCL shall be as follows:**

1. OCCL shall provide screw rod and coupler nut to the successful bidder, in phased manner, at Central Workshop, Rasulgarrh

### **Scope of Successful bidder to be as follows.**

1. All handling equipments and consumables required for the work shall be borne by the successful bidder.
2. The items listed in the BOQ are only indicative and there may be deletion & addition of the items as per requirement of OCCL.
3. Decision of the Engineer-in-Charge of the work of OCCL regarding the scope of work shall be final and binding on the successful bidder.

Signature of the Tenderer or his/their  
power of attorney holder  
with designation & seal.

Senior Manager (Mech.)-I  
OCC Ltd, Central Workshop,  
Rasulgarrh, Bhubaneswar-751010

## **TERMS AND CONDITIONS**

1. The tenderers shall quote their rates in the price schedule format in original per set basis only inclusive of all taxes, handling etc. The rates and amount shall be quoted both in figures and words.
2. The offer shall be valid for a period of 60 days from the date of opening of the tender.
3. Price escalation will not be allowed under any circumstances. The quoted rates shall be firm till execution of the entire order.
4. Delivery of stem rod and nut with complete threading as per specification shall be made within 08 ( eight) days from the date of receipt of the base materials from OCCL Store. Consignee of material will be Manager (Mech.), Store, Central Workshop, Rasulgarh, Bhubaneswar-10
5. 100% payment shall be made after receipt of stem screw and nut in complete shape & in full quantity at our OCCL Store subject to verification of suitability and receipt of proper test and guarantee certificate.
6. Conditional tenders with deviations shall not be accepted.
7. The authority reserves the right to accept/reject any or all tenders without assigning any reason thereof.
8. Any dispute arising out of this tender or order thereof is to be settled in proper court under the jurisdiction of Odisha High Court at Cuttack or courts under the jurisdiction of Odisha High Court at Bhubaneswar only.

Signature of the Tenderer or his/their  
power of attorney holder  
with designation & seal.

Senior Manager (Mech.)-I  
OCC Ltd, Central Workshop,  
Rasulgarh, Bhubaneswar-751010

**ODISHA CONSTRUCTION CORPORATION LTD.**  
(A GOVT. OF ODISHA UNDERTAKING)  
**CENTRAL WORKSHOP, RASULGARH,**  
**BHUBANESWAR-751010 (ORISSA)**

**PRICE SCHEDULE FOR**

**“TENDER FOR LABOUR CHARGES TOWARDS THREAD CUTTING ON SCREW ROD AND COUPLER NUT FOR LOWER SUKTEL IRRIGAION PROJECT”**  
**VIDE TENDER CALL NOTICE No. OCC/CWS/PROC/OFF-3/22/2023-24 Dated 03.06.2023 DUE ON 08.06.2023.**

S. No.	Description of Work	Unit	Total qty. in Unit	Rate per each In Rs.				Total amount in Rs.	
				Basic price	Taxes (GST)	Total in figures	Total in words	In figures	In words
1	Labour charges for Thread cutting on screw rod (TL – 205mm) & coupler nut (M 80 X 6 mm pitch thread) ( As per drawing in Annexure-I) (Each set consists of 1L & 1R )	Set	24 ( 12L + 12R)						

**N. B. The tenderers shall quote their rates in the price schedule format in original per set basis only inclusive of all charges & handling etc.**

Signature of the tenderer or his/their  
Power of attorney holder  
with designation & seal.

Senior Manager (Mech.)-I  
OCC Ltd, Central Workshop,  
Rasulgarh, Bhubaneswar-751010.



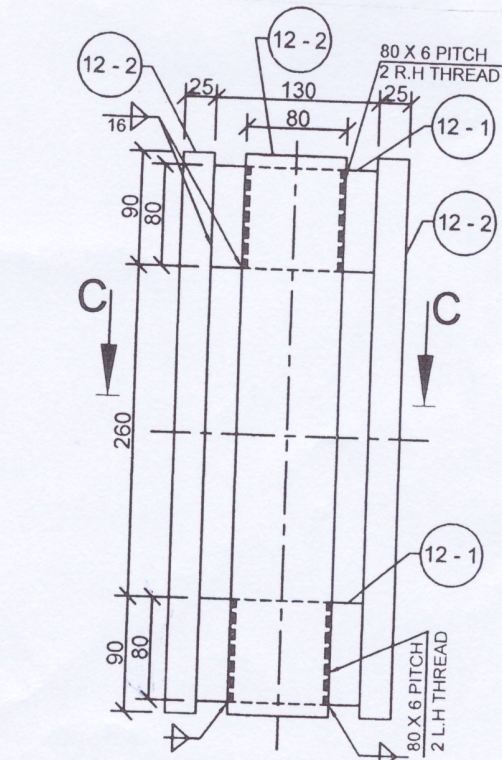

**ELEVATION**

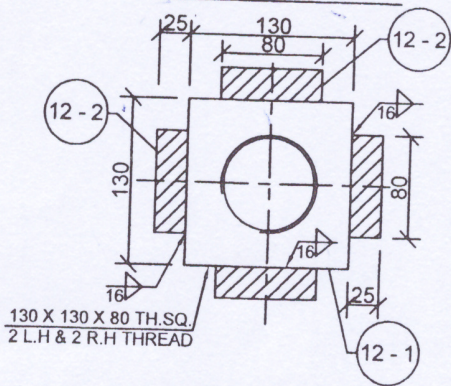

**SECTION-CC  
COUPLER NUT ASSEMBLY**

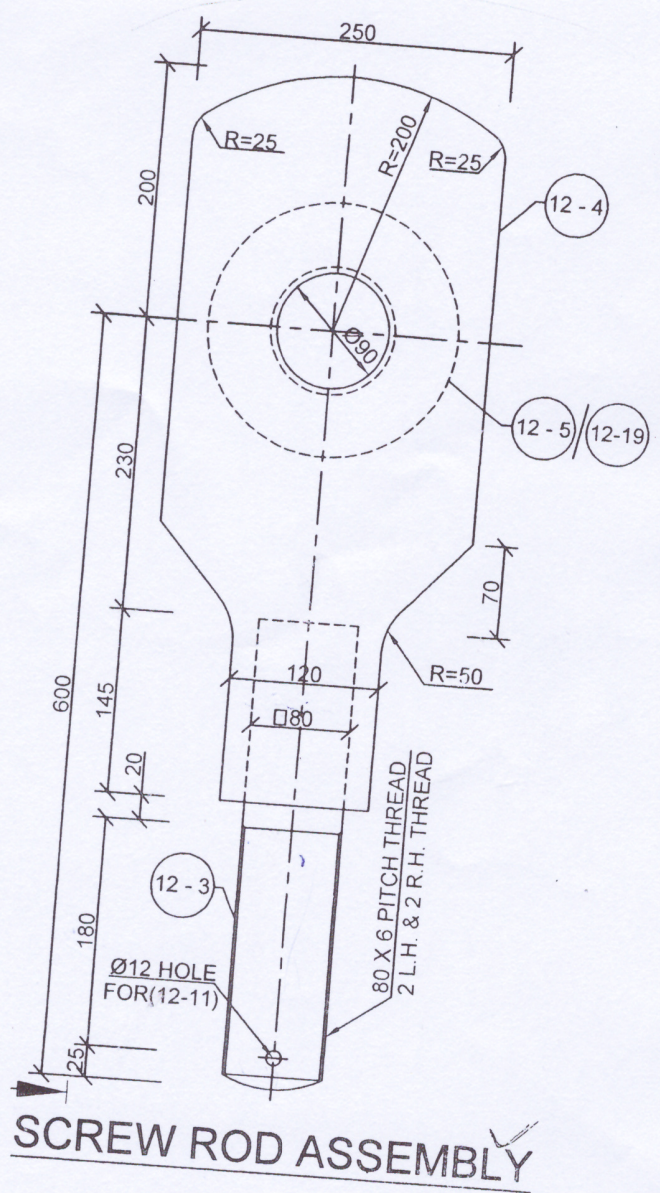

**SCREW ROD ASSEMBLY**

ROPE DRUM HOIST FOR  
CARRYING GATE OF LOWER