

ODISHA CONSTRUCTION CORPORATION LIMITED
(A GOVT. OF ODISHA UNDERTAKING)
CENTRAL WORKSHOP, RASULGARH,
BHUBANESWAR-751010 (ODISHA)

* * * * *

TENDER DOCUMENT FOR
“SUPPLY OF CASTING MATERIALS FOR 35T GANTRY CRANE FOR SPILLWAY STOPLOGS OF
TELENGIRI IRRIGATION PROJECT.

The tender document comprises of the following:

1)	Tender call notice No. OCC/CWS/PROC/ TIP-08/ 55 /2022-23 dated. 01.03.2023	01 (One) sheet
2)	Terms and conditions	04 (Four) sheets
4)	Drawings	09 (Nine) sheets
5)	Price schedule	02 (Two) sheet
Total :		16 (Sixteen) sheets

**Signature of the tenderer or his/their
power of attorney holder
with designation & seal.**

**Senior Manager (Mech.)-I
OCC Ltd, Central Workshop,
Rasulgarh, Bhubaneswar-751010**

ODISHA CONSTRUCTION CORPORATION LIMITED
(A GOVT. OF ODISHA UNDERTAKING)
CENTRAL WORKSHOP, RASULGARH,
BHUBANESWAR-751010 (ODISHA)

TENDER CALL NOTICE No. OCC/CWS/PROC/ TIP-08/ 55 /2022-23 dated. 01.03.2023

Sealed tenders in conformity with the terms, conditions, drawing and technical specifications in tender documents are invited from reputed manufacturers / traders for **"Supply of casting materials for 35T Gantry Crane for Spillway stoplogs of Telengiri Irrigation Project"** as per details below:

Cost of tender document (Non-refundable)	Sale of tender document		Earnest money deposit (EMD) required	Receipt of tender	Opening of Technical & price bid of tender
Rs. 6000/- GST @ 18% Rs. 7080/- by hand & Rs. 7180/- by Regd. Post/ courier	From 03.03.2023	To 17.03.2023 up to 1.00 PM	1(One)% of the total quoted value including GST	Up to 3.30 P.M. on 17.03.2023	At 4.00 PM on 17.03.2023

The tender document can be purchased by the interested reputed manufacturers or their authorized dealers / traders by hand from the office of the undersigned on deposit of cost of tender document i.e. **Rs.6000/-** plus GST @ 18% amounting to **Rs.7080/-** in cash or in shape of A/c. payee demand draft drawn in favour of **"Odisha Construction Corporation Limited"** - Project Account on any Nationalised Bank/ Scheduled Bank payable at Bhubaneswar (Non-refundable) and production of attested copies of the following documents and verification thereof by the undersigned. The tender document can also be obtained by the interested reputed manufacturers or their authorized dealers / traders by registered post, speed post/ courier on sending the cost of tender document i.e. **Rs.6000/-** plus GST @ 18% and postage charges of **Rs.100/-** amounting to **Rs.7180/-** in shape of A/c. payee demand draft drawn as stated above and attested copies of the following documents and verification thereof by the undersigned. The undersigned will not be responsible for any kind of delay by the postal/courier authorities.

- 1) Valid GST Registration Certificate.
- 2) PAN Card
- 3) The bidders have to submit copies of purchase orders, credentials, certificates etc. in support of supply of similar items of magnitude minimum amounting to 10.00 lakh in last 5 financial years (i.e. from financial year 2017-18 to 2021-22 including current financial year 2022-23).
- 4) Tenderer should submit valid manufacturer / trader registration certificate.

The tender document can also be downloaded from our Website www.odishaconstruction.com or Govt. of Odisha website www.odishagov.nic.in to submit the tender (**Bidders are requested to visit our website regularly for any changes since it will not be published in news paper again**). However, the cost of tender document i.e **Rs.6000/-** plus GST @ 18% amounting to **Rs.7080/-** in shape of A/c payee demand draft as stated above in favour of **"Odisha Construction Corporation Limited"** - Project Account on any Nationalised Bank/ Scheduled Bank payable at Bhubaneswar (Non-refundable) along with attested photo copies of all above documents should be submitted while submitting the tender in Envelope-I. Otherwise, the offer shall not be considered and OCCL will not be responsible for missing of any page while downloading. If there will be a public holiday on the last date of sale of tender document and receipt & opening of the tender as specified above, the tender document will be sold and tender will be received & opened on the next working day at the same time and venue.

The SSI/NSIC/MSME units participating in tender are not entitled for exemption from payment of Tender Paper costs as communicated vide DOWR Letter No. IIM-24/2018-14318/WR dated 24.05.2018 & Head Office, OCCL Letter No.5502/OCC/ CW-02/09(Vol-V)(WE) dated 30.05.2018.

The tenders will be opened in the presence of the tenderers or their authorised representatives. Tender through Fax/Telex/telegram/e-mail will not be accepted

The undersigned reserves the right to accept or reject any or all quotations without assigning any reason thereof

**Signature of the tenderer or his/their
power of attorney holder
with designation & seal.**

**Senior Manager (Mech.)-I
OCC Ltd, Central Workshop,
Rasulgarh, Bhubaneswar-751010**

ODISHA CONSTRUCTION CORPORATION LIMITED

(A GOVT. OF ODISHA UNDERTAKING)

CENTRAL WORKSHOP, RASULGARH,

BHUBANESWAR-751010 (ODISHA)

TERMS AND CONDITIONS OF TENDER FOR

**“SUPPLY OF CASTING MATERIALS FOR 35T GANTRY CRANE FOR SPILLWAY STOPLOGS OF
TELENGIRI IRRIGATION PROJECT”**

- 1) Reputed manufacturers/ traders having supplied similar item of similar magnitude earlier and satisfactorily accepted by the clients will be eligible to participate in the tender. The copies of purchase orders, credentials, certificates etc. in support of similar supply and satisfactory performance thereof will be furnished along with the tender.
- 2) Tender should be submitted in two bid system in two separate sealed covers and both will be submitted in a single sealed outer cover subscribing in bold letters as **“Supply of casting materials for 35T Gantry Crane for Spillway stoplogs of Telengiri Irrigation Project”** and also date of opening of tender. The name and address of the tenderer should not be written on outer cover. Only the name and address of the purchaser should be written on the outer cover.
- 3) The tenderer should submit Earnest Money Deposit (EMD) @ 1(One)% of the total quoted value along with the tender in shape of A/C payee Demand Draft drawn in favour of “Odisha Construction Corporation Limited” - Project Account on any Nationalised Bank / Scheduled bank payable at Bhubaneswar. The tenders received without EMD will be out rightly rejected. EMD of the unsuccessful tenderers will be released only after finalization of the tender.
- 4) i) The first envelope super scribing in bold letters as **“TECHNICAL BID”** should contain the following:
 - a. EMD of 1% as per clause- 3 above.
 - b. Attested copy of valid GST registration certificates. The tenderer will mention his GST Regn. No. in his tender clearly without which the tender will not be taken into consideration.
 - c. Attested copy of PAN Card.
 - d. The bidders have to submit copies of purchase orders, credentials, certificates etc. in support of supply of similar items of magnitude minimum amounting to 10.00 lakh in last 5 financial years (i.e. from financial year 2017-18 to 2021-22 including current financial year 2022-23).
 - e. Complete tender document in original including terms and conditions but without detailed specifications and price schedule duly signed on each page by the tenderer or his/their power of attorney holder. In case of power of attorney holder, an attested copy of power of attorney should be furnished.ii) Second envelope subscribing in bold letters **“SPECIFICATION AND PRICE SCHEDULE”** should contain detailed specifications and price schedule in original only duly filled in without leaving any column and line blank and signed on each page by the tenderer or his/their power of attorney holder.
- 5) The tender document can be purchased by the interested reputed manufacturers / traders by hand from the office of the undersigned from **03.03.2023** to **17.03.2023** (up to 1.00 P.M) during office hours on deposit of cost of tender document i.e. **Rs.6000/-** plus GST @ 18% amounting to **Rs.7080/-** in cash or in shape of A/c. payee demand draft drawn in favour of **“Odisha Construction Corporation Limited” - Project Account** on any Nationalized Bank / Scheduled Bank payable at Bhubaneswar (non-refundable) and production of attested copies of the following documents and verification thereof by the undersigned. The tender document can also be obtained by the interested reputed manufacturers / traders by registered post/speed post/courier on sending the cost of tender document i.e. **Rs.6000/-** plus GST @ 18% and postage charges of **Rs.100/-** amounting to **Rs.7180/-** in shape of A/C. payee demand draft drawn in favour of **“Odisha Construction Corporation Limited” - Project Account** on any Nationalized Bank / Scheduled Bank payable at Bhubaneswar (non-refundable) and sending attested copies of the following documents and verification thereof by the undersigned.

Signature of the tenderer or his/their
power of attorney holder
with designation & seal.

Senior Manager (Mech.)-I
OCC Ltd, Central Workshop,
Rasulgarh, Bhubaneswar-751010

- a. Valid GST Registration Certificate.
 - b. PAN Card
 - c. The bidders have to submit copies of purchase orders, credentials, certificates etc. in support of supply of similar items of magnitude minimum amounting to 10.00 lakh in last 5 financial years (i.e. from financial year 2017-18 to 2021-22 including current financial year 2022-23).
 - d. Tenderer should submit valid manufacturer / trader registration certificate
 - e. Tenderer should submit format of Bid Security Declaration from Bidder in lieu of EMD.
- 6) The tender document can also be downloaded from our Website www.odishaconstruction.com or Govt. of Odisha website www.odishagov.nic.in to submit the tender (**Bidders are requested to visit our website regularly for any changes since it will not be published in news paper again**). However, the cost of tender document i.e. **Rs.6000/-** plus GST @ 18% amounting to **Rs.7080/-** in shape of A/C. payee demand draft, as stated above in favour of "Odisha Construction Corporation Limited" - Project Account on any Nationalized Bank/ Scheduled Bank payable at Bhubaneswar (non-refundable) along with attested photo copies of all above documents should be submitted, while submitting tender in Envelope-I, otherwise, the tender will be cancelled. OCCL will not be responsible for missing of any page while downloading.
- 7) The tenders will be received up to **3.30 PM** on and same will be opened in the office of the undersigned on the same day at **4.00 PM** in presence of the tenderers or their authorized representatives, if they so desire. If there will be a public holiday on the last date of sale of tender document and receipt & opening of the tenders as specified above, the tender document will be sold and tenders will be received & opened on the next working day at the same time and venue.
- 8) The undersigned will not be responsible for any kind of delay in receipt of tenders by the postal/courier authorities.
- 9) The **PRICE SCHEDULE BID & TECHNICAL BID** will be opened on **17.03.2023 at 4.00 PM**. Then the documents in the first envelope submitted by the tenderers will be scrutinized preliminarily on the spot. The second envelope of the valid eligible tenders after preliminary scrutiny of the documents in the first envelope will be opened on the same day immediately subject to fulfilling the requirements mentioned in the tender schedule.
- 10) The materials should be supplied in finished / fully machined conditions by successful tenderer / supplier as per required dia, length and quantity and should strictly conform to relevant standards of Bureau of Indian Standard (BIS) as mentioned in detailed specification and price schedule.
- 11) The original test certificate of materials from a Govt./Govt. approved testing laboratory will be provided by the successful tenderer/ supplier along with supply of materials. The manufacturer's test certificate will have to be also furnished by the successful tenderer/ supplier. The purchaser is having the option to test the materials in any laboratory at the cost of the supplier and if the materials are not found in accordance with the specifications and grade in relevant Indian Standards, the materials will be rejected.
- 12) The materials will be guaranteed by the supplier against any defect for a period of 18 months from the date of supply or 12 months from the date of use, whichever is earlier. Guarantee certificate in this regard will accompany with supply of materials. If any defect is found in the materials within the guarantee period, the same will have to be replaced free of cost by the supplier.

**Signature of the tenderer or his/their
power of attorney holder
with designation & seal.**

**Senior Manager (Mech.)-I
OCC Ltd, Central Workshop,
Rasulgarh, Bhubaneswar-751010**

- 13) The rate of materials should be quoted by the tenderer on unit basis only. The same should be supplied by the successful supplier as per required dia, length and quantity in numbers as mentioned in detail specification and Price Schedule.
- 14) Pre-delivery inspection (P.D.I) before despatch of the materials will be made at the manufacturer's works by the authorized representative of the purchaser / client / third party for which the manufacturer should intimate in writing for P.D.I. 10 days in advance regarding readiness for P.D.I.
- 15) The tenderer will quote their rates F.O.R. OCCL Store, Central Workshop, Rasulgarh, Bhubaneswar-10 (Odisha) indicating separately the basic price, packing, forwarding, transportation, transit insurance, handling charges, taxes, duties, levies etc. strictly in the specifications and price schedule format in original. All columns and lines of the specification and price schedule should be filled in properly without leaving any thing blank. The details and rates of duties, taxes etc. should be indicated clearly in the specification and price schedule.
- 16) The tenderer should quote appropriate taxes with the offer.
- 17) The rates and amounts should be quoted both in figures and words in the price schedule. Any correction or overwriting in the specification and price schedule should be duly certified by the tenderer or his power of attorney holder. In case of any mismatch in figures and words, the rates in words will be considered. In case of any mismatch in rates and amount, the rate will be considered.
- 18) 90% payment will be made within 30 days of receipt, verification and acceptance of the complete materials along with bill, test certificate, guarantee certificate and other documents. Balance 10% will be released after 18 months of supply or 12 months from the date of commissioning whichever is earlier. However if a performance bank guarantee is received for 10% of the value of materials, the same will be released within 60 days from the date of receipt of materials.
- 19) The purchaser reserves the right to forfeit and encash the performance bank guarantee in full in case any bronze casting is found defective and not replaced by the tenderer/supplier within a suitable time fixed by the corporation. Any repair to the bronze casting shall be made only after approval of the purchaser. In this connection, the decision of the purchaser is final and binding on the tenderer/supplier.
- 20) Price escalation will not be allowed under any circumstances. The quoted rates will remain firm till execution of the work order.
- 21) The validity of the offer should be for a period of 120 (One hundred twenty) days from the date of opening of the tender.
- 22) The complete ordered quantity shall be supplied by the successful tenderer within 90 (Ninety) days from the date of issue of purchase order failing which the order is liable for cancellation without assigning any reason thereof by the purchaser. In case of cancellation of the order the EMD will be forfeited. In case of any delay in supply of material beyond the delivery schedule whatever may be the reason, supplier shall be liable to pay L.D. @ 0.5% (Half percent) of the total order value per week of delay or part thereof subject to a maximum of 5% (Five percent) of the total order value.

**Signature of the tenderer or his/their
power of attorney holder
with designation & seal.**

**Senior Manager (Mech.)-I
OCC Ltd, Central Workshop,
Rasulgarh, Bhubaneswar-751010**

- 23) After submission of tender and before placing order, the bidder may be asked by the undersigned to attend techno-commercial discussions and reply to queries within a specified period. If the bidder fail to do so, the tender submitted by the bidder is liable to be cancelled.
- 24) Conditional offers with deviations will not be accepted. Those, who do not agree to the terms and conditions regarding payments, delivery and others, need not quote.
- 25) The authority reserves the right to accept/reject any or all tenders without assigning any reason thereof. The required quantity of materials can be splitted among the two or more tenderers. In this connection, the decision of purchaser is final and binding on the tenderer.
- 26) The duplicate copy of the order shall be signed by the supplier on each page with his seal as acceptance of the order and shall be returned to the purchaser within 07 (Seven) days of receipt of this order failing which the order is liable for cancellation.
- 27) Tender through fax/telex/telegram/e-mail will not be accepted.
- 28) Any dispute arising out of this tender or order thereof is to be settled in proper court under the jurisdiction of Odisha High Court at Cuttack or courts under the jurisdiction of Odisha High Court at Bhubaneswar only.

**Signature of the tenderer or his/their
power of attorney holder
with designation & seal.**

**Senior Manager (Mech.)-I
OCC Ltd, Central Workshop,
Rasulgarh, Bhubaneswar-751010**

ODISHA CONSTRUCTION CORPORATION LIMITED
(A GOVT. OF ODISHA UNDERTAKING)
CENTRAL WORKSHOP, RASULGARH,
BHUBANESWAR-751010 (ODISHA).

DETAILED SPECIFICATION AND PRICE SCHEDULE FOR
“SUPPLY OF CASTING MATERIALS FOR 35T GANTRY CRANE FOR SPILLWAY STOPLOGS OF TELENGIRI IRRIGATION PROJECT”

VIDE TCN No.OCC/CWS/PROC/TIP-08 / 55 /2022-23 DATED. 01.03.2023 DUE DATE OF OPENING ON DATED 17.03.2023

Sl. No.	Description of Item	Part No	Unit	Qty. Reqd. in unit	Rate per unit in Rs.					Total amount in Rs. for full materials	
					Basic Price per unit	Packing, forwarding, transportation, transit insurance, handling charges, incidental charges etc.	GST as applicable	Total in figures	Total in words	In figure	In words
1	Wire rope drum-As per drawing C.S.GR.340-570W of IS:1030-1989 in Annexure-I	3-1	Nos.	2							
2	Wire rope clamp-As per drawing C.S.GR.340-570W of IS:1030-1989 in Annexure-II	3-2	Nos.	2							
3	Bronze bush-As per drawing (LTB-1 of IS:318-1981) in Annexure-III	3-3	Nos.	4							
4	Drum gear -As per drawing High Strength Steel Casting Gr.3-CS 840 of IS:2644 – 1994 in Annexure-IV	4-1	Nos.	2							
5	1st pinion - As per drawing High Strength Steel Casting Gr.4-CS 1030 of IS:2644 – 1994 in Annexure-V	4-2	Nos.	2							

**Signature of the tenderer or his/their
power of attorney holder
with designation & seal.**

**Senior Manager (Mech.)-I
OCC Ltd, Central Workshop,
Rasulgarh, Bhubaneswar-751010**

Sl. No.	Description of Item	Part No	Unit	Qty. Reqd. in unit	Rate per unit in Rs.					Total amount in Rs. for full materials	
					Basic Price per unit	Packing, forwarding, transportation, transit insurance, handling charges, incidental charges etc.	GST as applicable	Total in figures	Total in words	In figure	In words
6	Second gear-As per drawing High Strength Steel Casting Gr.3-CS 840 of IS:2644 – 1994 in Annexure-VI	4-3	Nos.	2							
7	Second pinion - As per drawing High Strength Steel Casting Gr.4-CS 1030 of IS:2644 – 1994 in Annexure-VII	4-4	Nos.	2							
8	Pulley -As per drawing Cast steel GR.340 - 570W of IS:1030-1998 in Annexure-VIII	4-5	Nos.	4							
9	Bush for Pulley - As per drawing LTB-1 of IS:318 – 1981 in Annexure-IX	4-6	Nos.	8							

Signature of the tenderer or his/their power of attorney holder with designation & seal.

Page 2 of 2

**Senior Manager (Mech.)-I
OCC Ltd, Central Workshop,
Rasulgarh, Bhubaneswar-751010**

Annexure - I
6 NOS. Ø25 REAMED HOLE
ON 950 P.C.D.

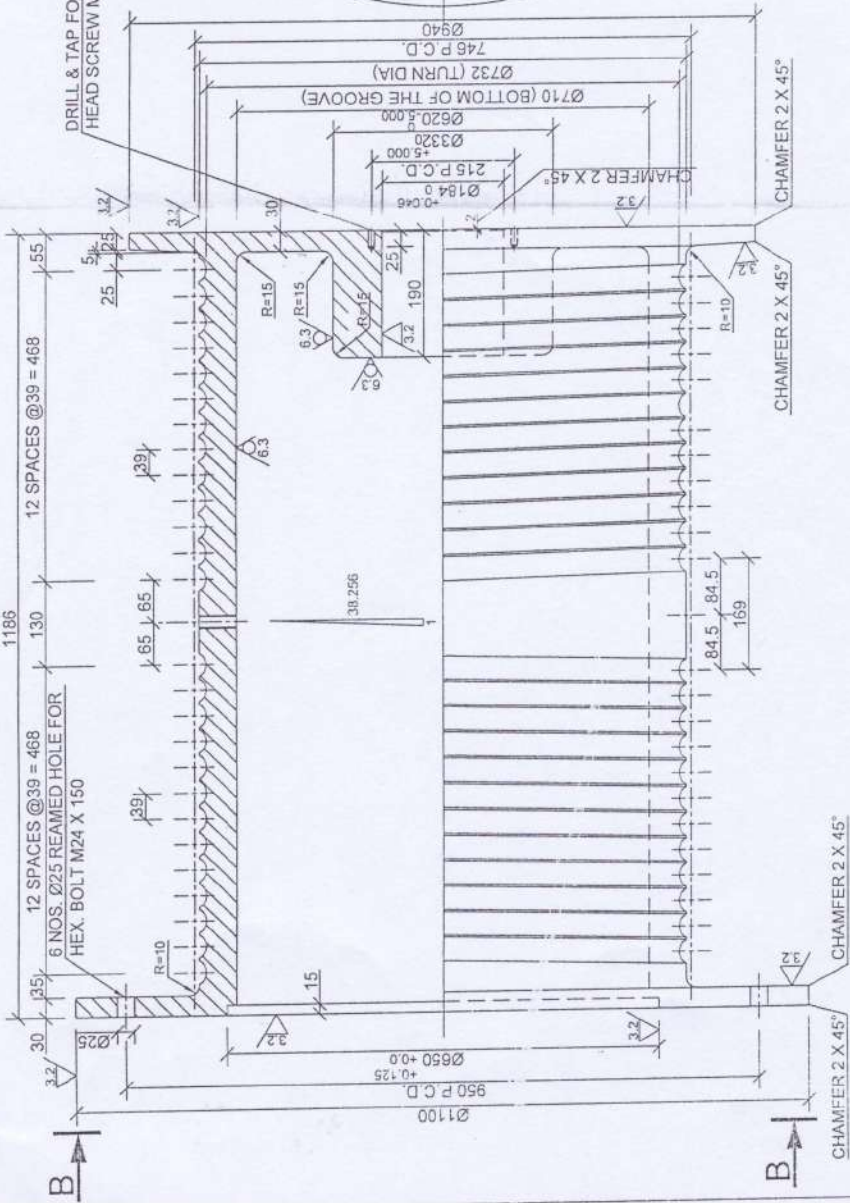

**HALF SECTIONAL ELEVATION AT - AA
U/S VIEW OF RIGHT ROPE DRUM**

PART NO. 05-12-05-00-03-01
MATERIAL :- CAST STEEL GR. 340-570W OF IS:1030-1989
TOTAL NOS. REQD. - ONE SET (1 LEFT, 1 RIGHT)

- NOTES :-**
1. ALL DIMENSIONS ARE IN mm OF THE FINISHED PART.
 2. ALL CASTING SHALL BE SUPPLIED IN FULLY ANNEALED CONDITION.
 3. SUITABLE MACHINING ALLOWANCES (NOT LESS THAN 5 mm ON TOOL POINT) SHALL BE PROVIDED ON ALL SURFACES INDICATED TO BE MACHINED.
 4. THE FINISHES AND TOLERANCES SHOWN ARE FOR THE FINISHED PART ONLY.
 5. ONE LEFT DRUM ASSEMBLY & ONE RIGHT DRUM ASSEMBLY SHALL CONSTITUTE ONE SET
 6. DRILL & TAP FOR SCREW M10 X 30 SHALL BE DONE WITH THE MATCHING PART.

VIEW-BB

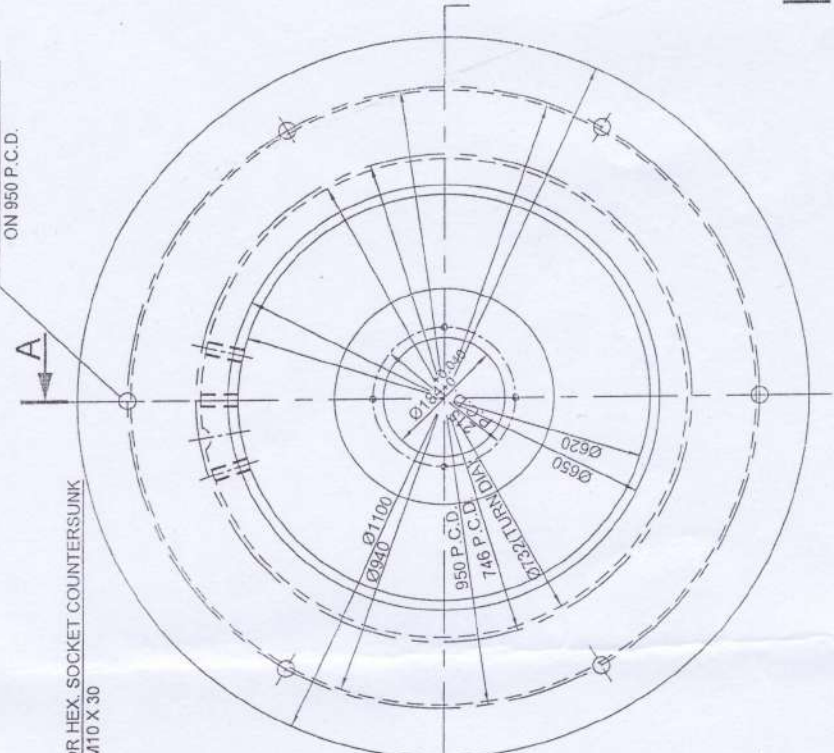

REF. DRG.
1. 05-12-05-00-03

TELENGIRI IRRIGATION PROJECT		O.C.C.LTD.	
35 T GANTRY CRANE FOR SPILLWAY STOPLOG			
DRAWN	Checked	SUBMITTED	APPROVED
	<i>[Signature]</i>	<i>[Signature]</i>	<i>[Signature]</i>
ROPE DRUM		ROPE DRUM	

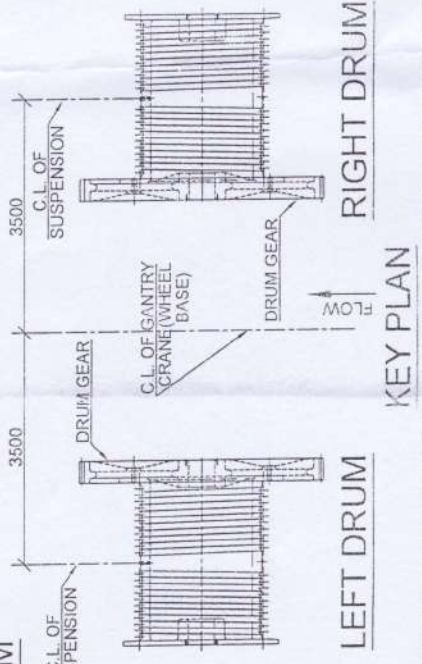

KEY PLAN

JULY 2021
DRG.NO. - 05-12-05-01-03-01

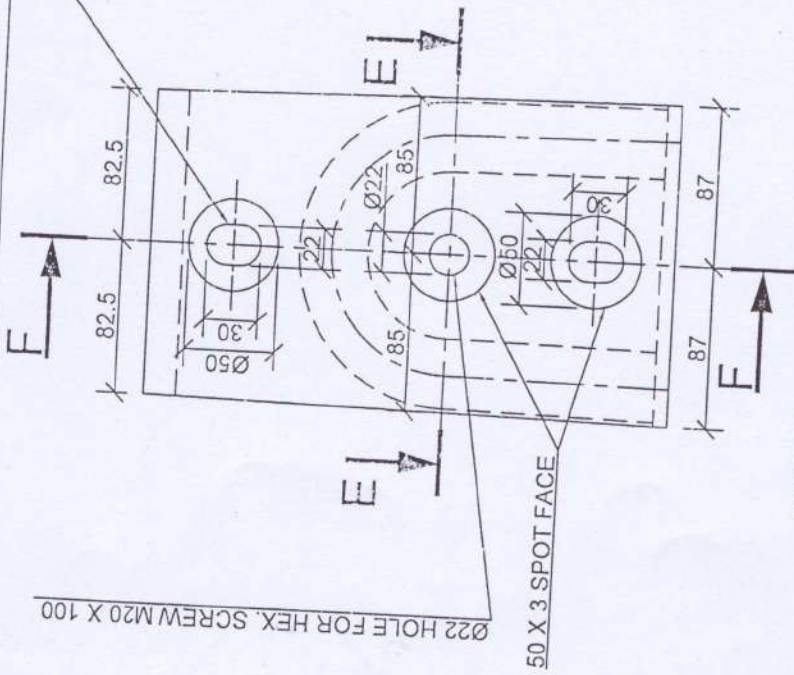

WIRE ROPE CLAMP

PART NO.- 05-12-05-00-03-02
 MATERIAL:- CAST STEEL GR. 340-570W OF IS:1030-1989
 TOTAL NOS. REQD. = 2 (TWO)

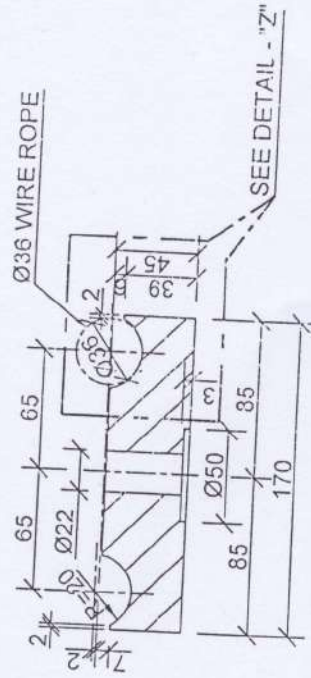

SECTION - EE

30 X 22 SLOTTED HOLE FOR
 HEX. SCREW M20 X 100

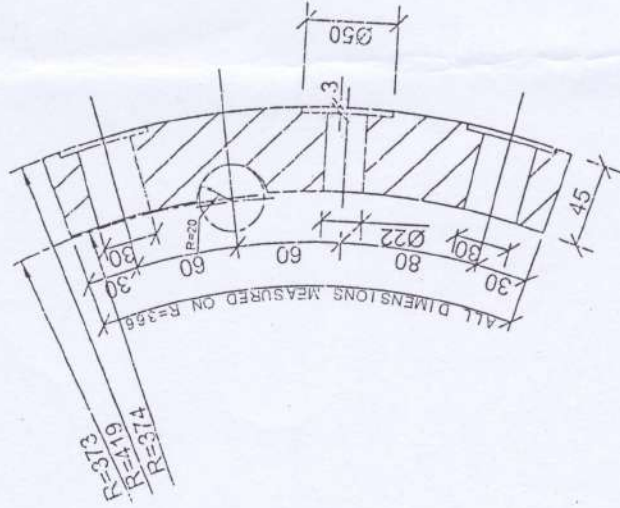

SECTION - FF

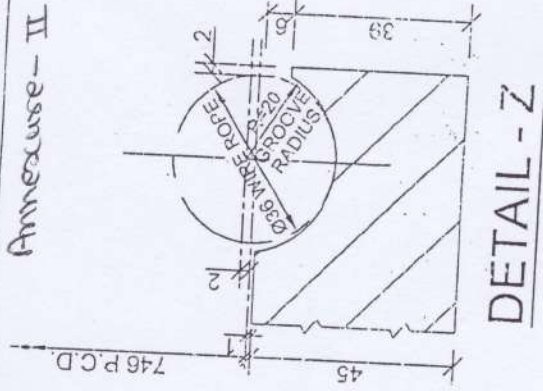

DETAIL - Z

NOTES:-

1. ALL DIMENSIONS ARE IN mm.

REF. DRG.

1. 05-12-05-00-03

**TELANGIRI IRRIGATION
 PROJECT**

35 T GANTRY CRANE FOR
 SPILLWAY STOPLOG

ROPE CLAMP

O.C.C.LTD.

DRAWN

CHECKED

SUBMITTED

APPROVED

JULY
2021

DRG.NO.- 05-12-05-01-03-02

Amesur de III

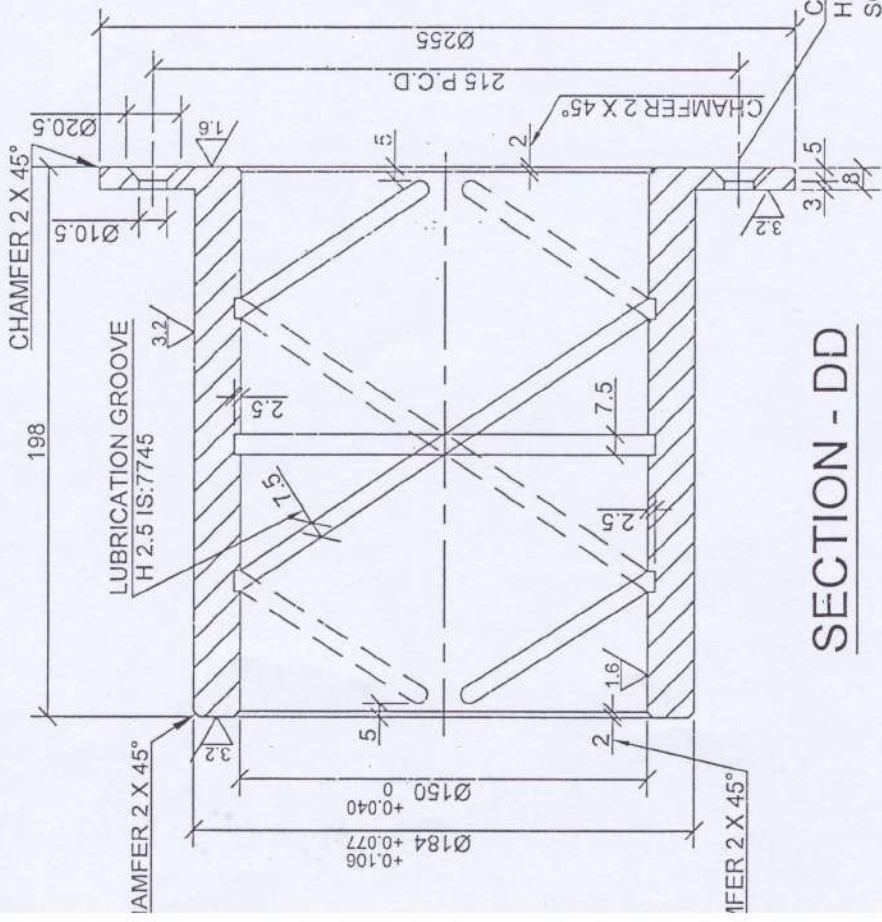
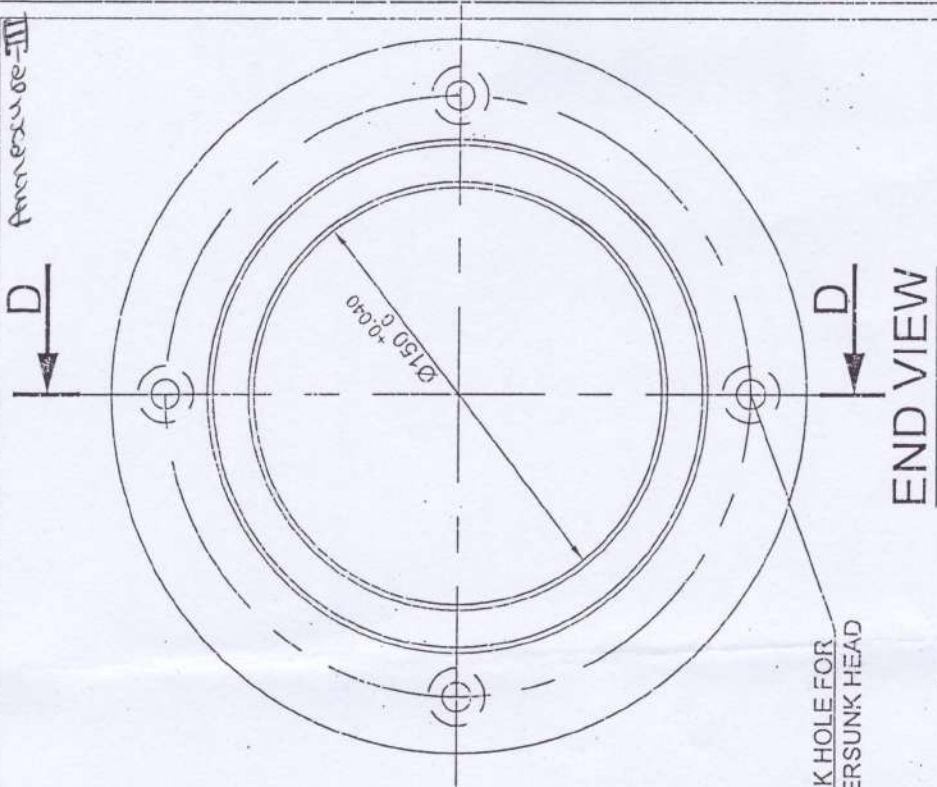

PART NO. - 05-12-05-00-03-03
 MATERIAL:- LEADED TIN BRONZE GR. LTB -1 OF IS:318-1981
 TOTAL NOS. REQD. - 4 (FOUR)

NOTES-

ALL DIMENSIONS SHOWN ARE IN mm OF THE FINISHED PART.
 THE FINISHES & TOLERANCES INDICATED ARE FOR FINISHED PART ONLY.
 FITTABLE MACHINING ALLOWANCE (NOT LESS THAN 5mm ON TOOL POINT) SHALL
 BE PROVIDED ON ALL SURFACES INDICATED FOR MACHINING.
 DRILL & TAP FOR SCREW M10 X 30 SHALL BE DONE WITH MATCHING PART.

REF.DRG.
 1. 05-12-05-00-03

TELENGIRI IRRIGATION

PROJECT

35 T GANTRY CRANE FOR
 SPILLWAY STOPLOG

BRONZE BUSH

O.C.C.LTD.

DRAWN	<i>[Signature]</i>
CHECKED	<i>[Signature]</i>
SUBMITTED	<i>[Signature]</i>
APPROVED	<i>[Signature]</i>

JULY
2021

DRG.NO.- 05-12-05-01-03-03

A CUT 138 TEETH 14 mm MODULE 20° P.A.
FULL DEPTH INVOLUTE

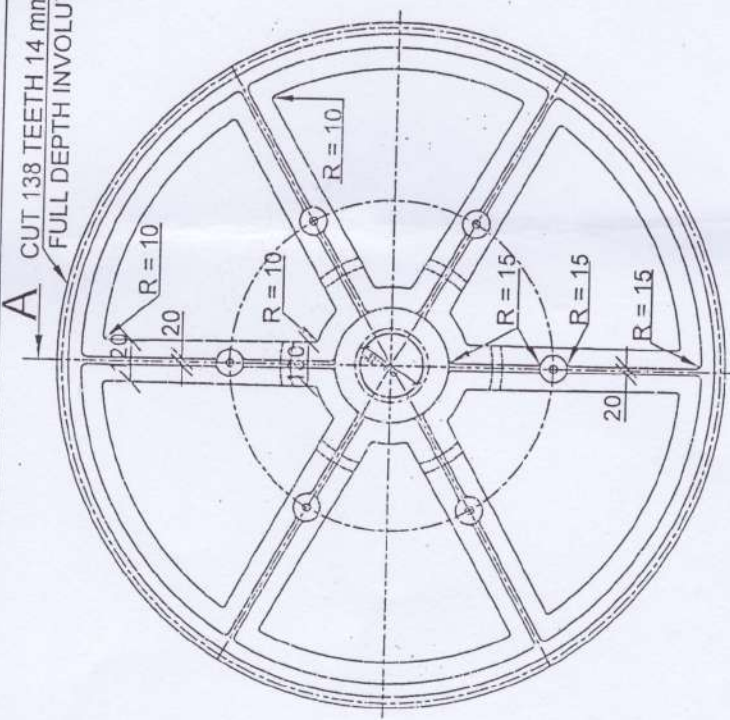

END VIEW

REF.DRG.

1. 05-12-05-00-04

TELANGIRI IRRIGATION PROJECT

O.C.C.LTD.

DRAWN	<i>[Signature]</i>
CHECKED	<i>[Signature]</i>
SUBMITTED	<i>[Signature]</i>
APPROVED	<i>[Signature]</i>

35 T GANTRY CRANE FOR SPILLWAY STOPLOG

DRUM GEAR

JULY 2021

DRG.NO.- 05-12-05-01-04-01

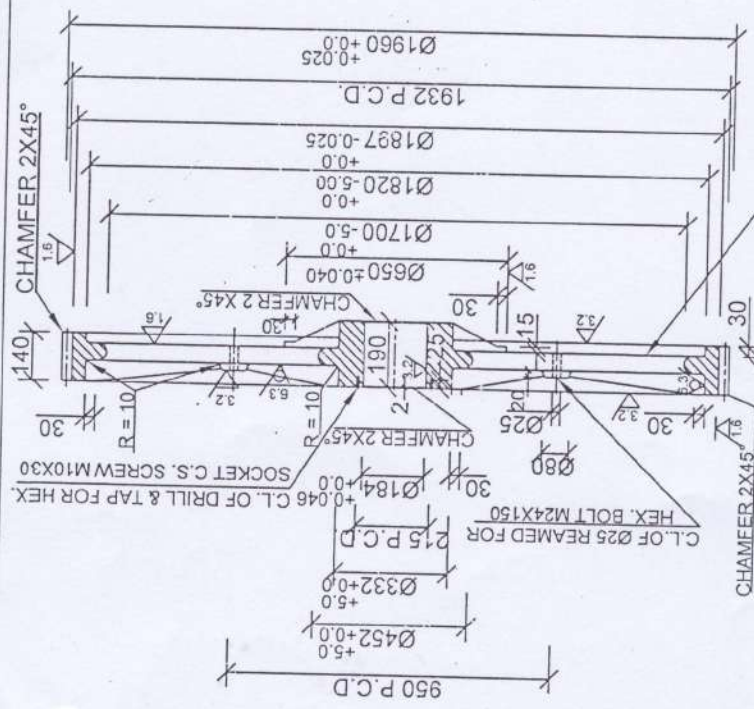

SECTION - AA

DRUM GEAR

PART NO. - 05-12-05-00-04-01

MATERIAL - HIGH STRENGTH STEEL CASTING GR.3 - CS 840

OF IS:2644 - 1994

TOTAL NOS. REQD. = 2 (TWO)

NOTES:-

1. ALL DIMENSIONS ARE IN mm OF THE FINISHED PART.
 2. THE FINISHES AND TOLERANCES GIVEN ARE FOR THE FINISHED PART ONLY.
 3. SUITABLE MACHINING ALLOWANCES (NOT LESS THAN 5 mm ON TOOL POINT) SHALL BE PROVIDED ON ALL SURFACES INDICATED TO BE MACHINED.
 4. THE CASTING SHALL BE SUITABLY HEAT TREATED SO AS TO ATTAIN THE SPECIFIED MECHANICAL PROPERTIES.
- THE CASTING SHALL BE FREE FROM DEFECTS THAT WILL ADVERSELY AFFECT THE MACHINING OR UTILITY OF THE CASTING.
- DRILL & TAP FOR SCREW M10 X 30 SHALL BE DONE WITH THE MATCHING PART.

Amexuse - V

CUT 21 TEETH 14 mm MODULE 20° P.A.
FULL DEPTH INVOLUTE

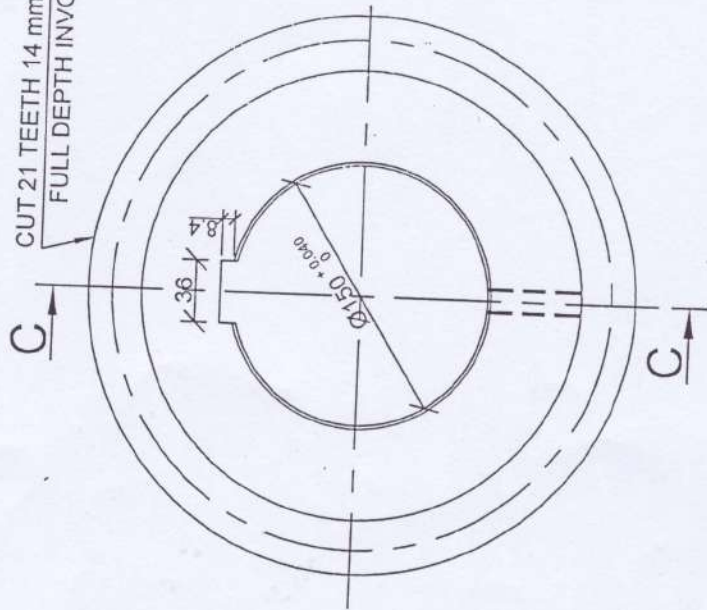

END VIEW

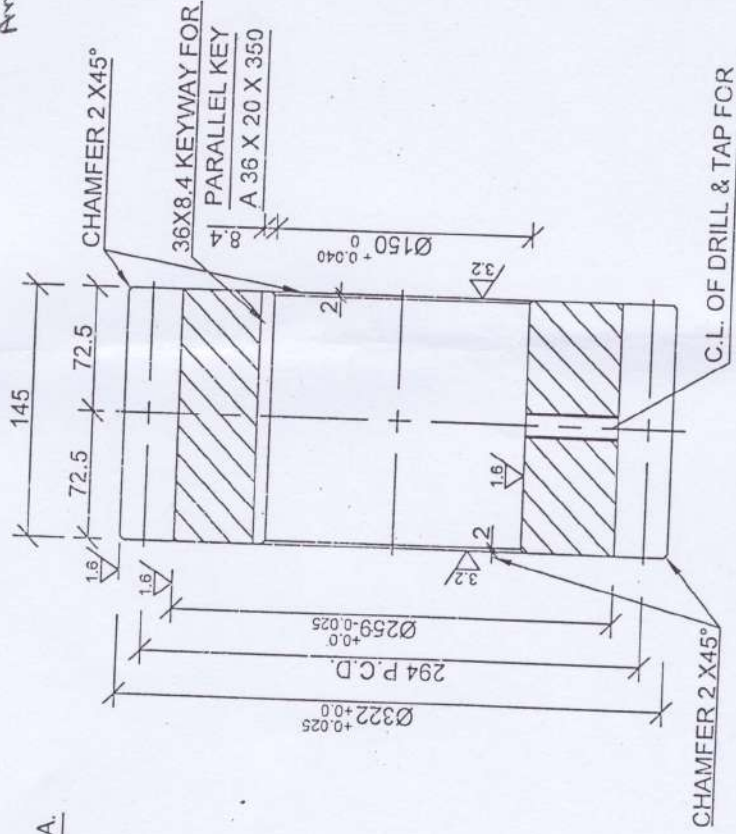

SECTION - CC

1ST. PINION

PART NO.- 05-12-05-00-04-02
MATERIAL - HIGH STRENGTH STEEL CASTING GR.4 - CS 1030
OF IS:2644-1994
TOTAL NOS. REQD. = 2 (TWO)

REF.DRG.

1.05-12-05-00-04

NOTES:-

ALL DIMENSIONS ARE IN mm OF THE FINISHED PART.
THE CASTING SHALL BE FREE FROM DEFECTS THAT WILL ADVERSELY AFFECT THE UTILITY
SUITABLE MACHINING ALLOWANCES (NOT LESS THAN 5 mm ON TOOL POINT)
SHALL BE PROVIDED ON ALL SURFACES INDICATED TO BE MACHINED.
THE FINISHES AND TOLERANCES GIVEN ARE FOR THE FINISHED PART ONLY.
DRILL & TAP FOR GRUB SCREW CM 12 X 50 SHALL BE DONE ALONG WITH
MATCHING PART.

TELENGIRI IRRIGATION
PROJECT

35 T GANTRY CRANE FOR SPILLWAY
STOPLOG

1ST. PINION

O.C.C.LTD.

DRAWN

CHECKED

SUBMITTED

APPROVED

JULY
2021

DRG.NO.- 05-12-05-01-04-02

Ammeasure - VI

CUT 72 TEETH 10 mm MODULE 20° P.A.
FULL DEPTH INVOLUTE

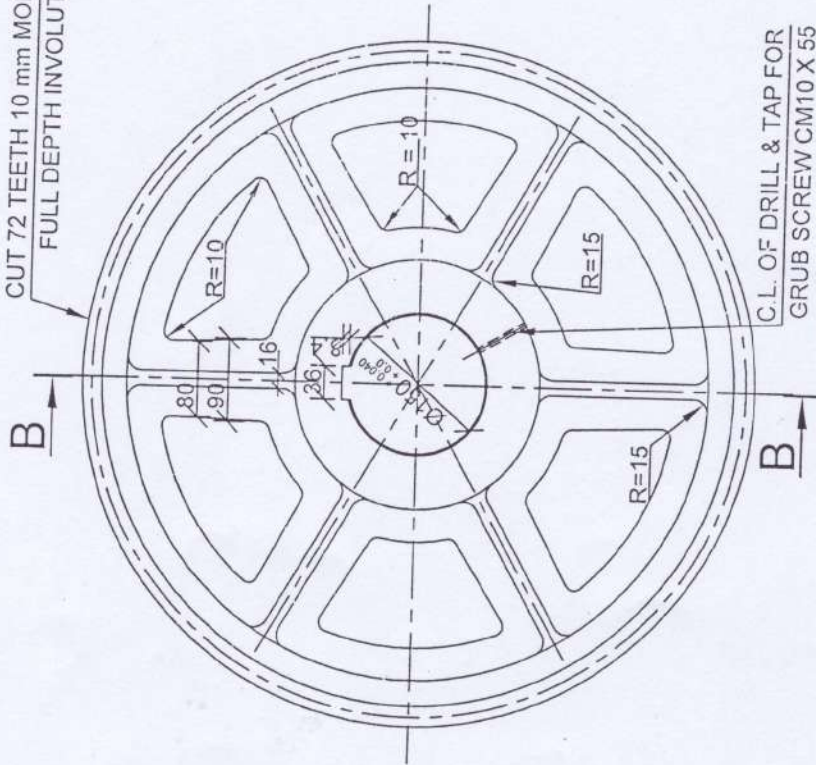

END VIEW

C.L. OF DRILL & TAP FOR
GRUB SCREW CM10 X 55

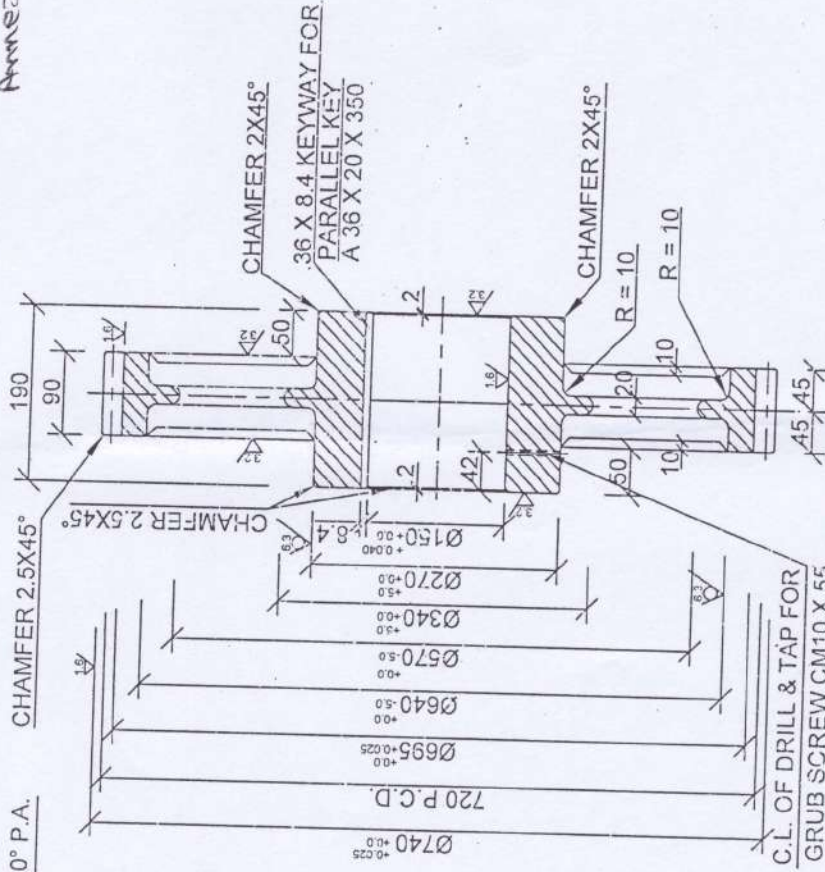

2ND. GEAR

SECTION - BB

REF.DRG.

PART NO. - 05-12-05-00-04-03
MATERIAL - HIGH STRENGTH STEEL CASTING GR.3 - CS 840
OF IS:2644-1994
TOTAL NOS. REQD. = 2 (TWO)

OTES:-

ALL DIMENSIONS ARE IN mm OF THE FINISHED PART.
THE FINISHES AND TOLERANCES GIVEN ARE FOR THE FINISHED PART ONLY.
SUITABLE MACHINING ALLOWANCES (NOT LESS THAN 5 mm ON TOOL POINT)
SHALL BE PROVIDED ON ALL SURFACES INDICATED TO BE MACHINED.
THE CASTING SHALL BE SUITABLY HEAT TREATED SO AS TO ATTAIN THE
SPECIFIED MECHANICAL PROPERTIES.
THE CASTING SHALL BE FREE FROM DEFECTS THAT WILL ADVERSELY AFFECT
MACHINING OR UTILITY OF THE CASTING.
DRILL & TAP FOR GRUB SCREW CM10 X 55 SHALL BE DONE WITH THE MATCHING PART.

TELENGIRI IRRIGATION

PROJECT

35 T GANTRY CRANE FOR SPILLWAY
STOPLOG

2ND. GEAR

JULY
2021

DRG.NO.- 05-12-05-01-04-03

O.C.C.LTD.

DRAWN

CHECKED

SUBMITTED

APPROVED

(Signature)
(Signature)
(Signature)
(Signature)

1.05-12-05-00-04

Amenduse - VII

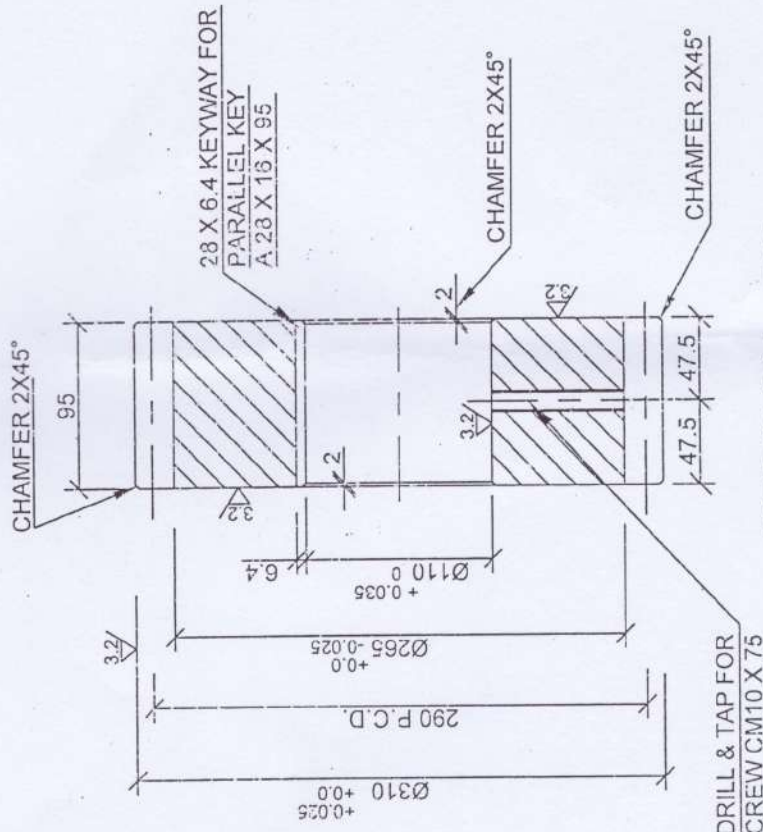

REF.DRG.

1.05-12-05-00-04

SECTION - DD

2ND. PINION

PART NO. - 05-12-05-00-04-04
 MATERIAL - HIGH STRENGTH STEEL CASTING GR.4 - CS 1030
 OF IS:2644 - 1994
 TOTAL NOS. REQD. = 2 (TWO)

CUT 29 TEETH 10 mm MODULE 20° P.A.
 FULL DEPTH INVOLUTE

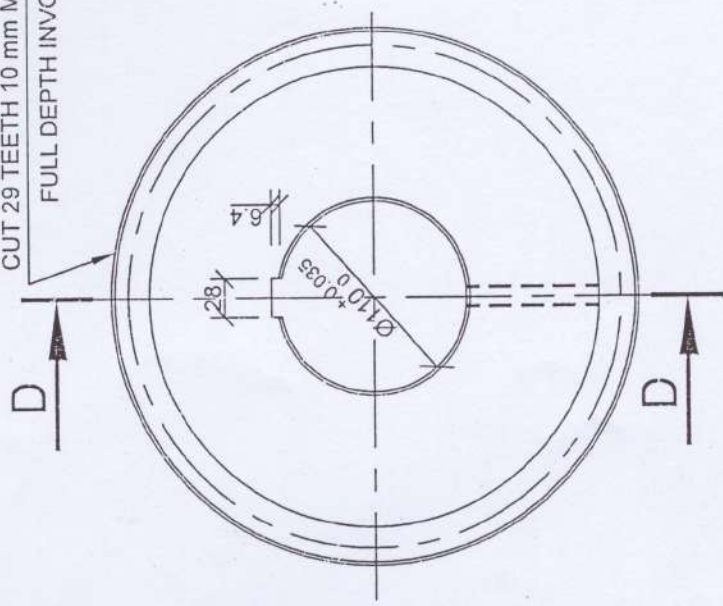

END VIEW

NOTES:-

ALL DIMENSIONS ARE IN mm OF THE FINISHED PART.
 THE CASTING SHALL BE FREE FROM DEFECTS THAT WILL ADVERSELY AFFECT THE UTILITY
 SUITABLE MACHINING ALLOWANCES (NOT LESS THAN 5 mm ON TOOL POINT)
 SHALL BE PROVIDED ON ALL SURFACES INDICATED FOR MACHING.
 THE FINISHES AND TOLERANCES GIVEN ARE FOR THE FINISHED PART ONLY.
 DRILL & TAP FOR GRUB SCREW CM10X75 SHALL BE DONE ALONG WITH THE MATCHING
 PART.

TELENGIRI IRRIGATION PROJECT		O.C.C.LTD.	
35 T GANTRY CRANE FOR SPILLWAY STOPLOG		DRAWN	<i>R. Raju</i>
2ND. PINION		CHECKED	<i>Chinnayya</i>
		SUBMITTED	<i>Dr. D. D.</i>
		APPROVED	<i>Dr. D. D.</i>
JULY 2021	DRG.NO.- 05-12-05-01-04-04		

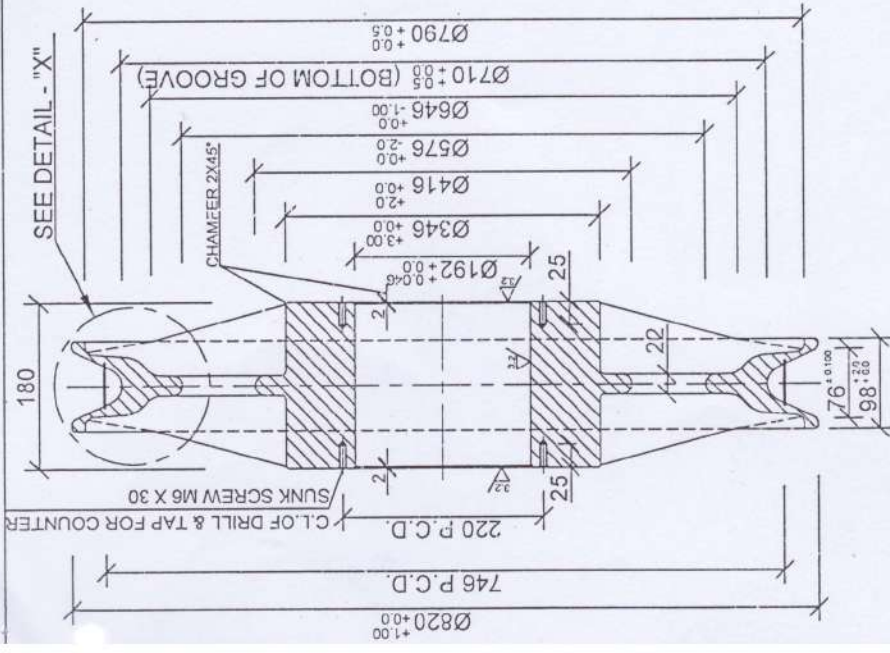

SECTION - EE PULLEY

PART NO. - 05-12-05-00-04-05
 MATERIAL - CAST STEEL GR. 340-570W OF IS:1030-1998
 TOTAL NOS. REQD. = 4 (FOUR)

NOTES:-

1. ALL DIMENSIONS ARE IN mm OF THE FINISHED PART.
 2. THE FINISHES AND TOLERANCES GIVEN ARE FOR THE FINISHED PART ONLY.
 3. SUITABLE MACHINING ALLOWANCES (NOT LESS THAN 5 mm ON TOOL POINT) SHALL BE PROVIDED ON ALL SURFACES INDICATED FOR MACHINING.
 4. THE CASTING SHALL BE SUITABLY HEAT TREATED SO AS TO ATTAIN THE SPECIFIED MECHANICAL PROPERTIES.
 5. THE CASTING SHALL BE FREE FROM DEFECTS THAT WILL ADVERSELY AFFECT MACHINING OR UTILITY OF THE CASTING.
- DILL & TAP FOR SCREW M16 X 30 SHALL BE DONE WITH THE MATCHING PART.

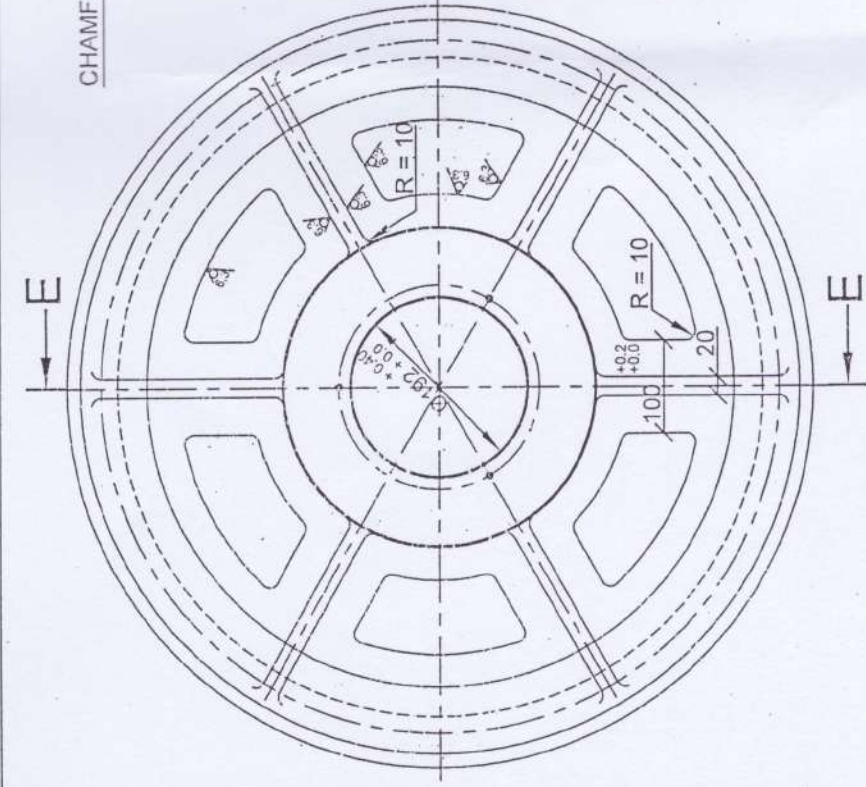

END VIEW

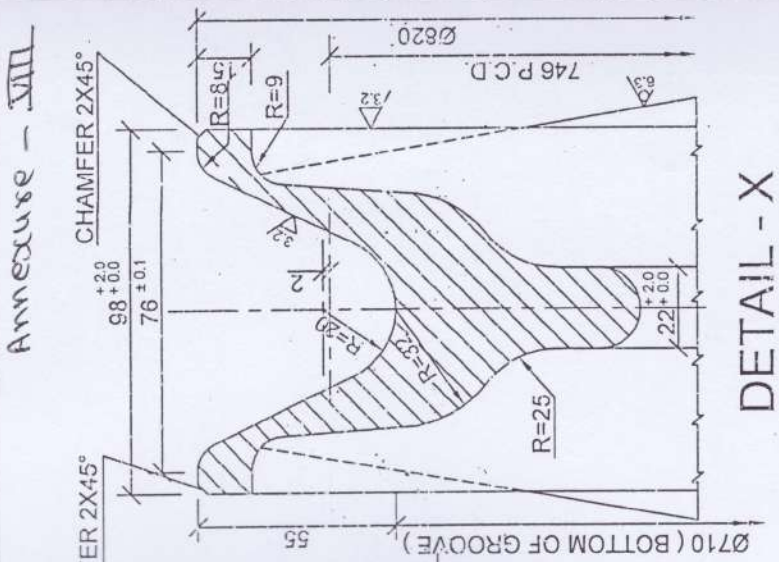

DETAIL - X

REF.DRG.

1.05-12-05-00-04

Annexure - VIII

TELANGIRI IRRIGATION PROJECT		O.C.C.LTD.	
35 T GANTRY CRANE FOR SPILLWAY STOPLOG		DRAWN	<i>[Signature]</i>
PULLEY		CHECKED	<i>[Signature]</i>
		SUBMITTED	<i>[Signature]</i>
		APPROVED	<i>[Signature]</i>
JULY 2021	DRG.NO.- 05-12-05-01-04-05		

Annexure - IX

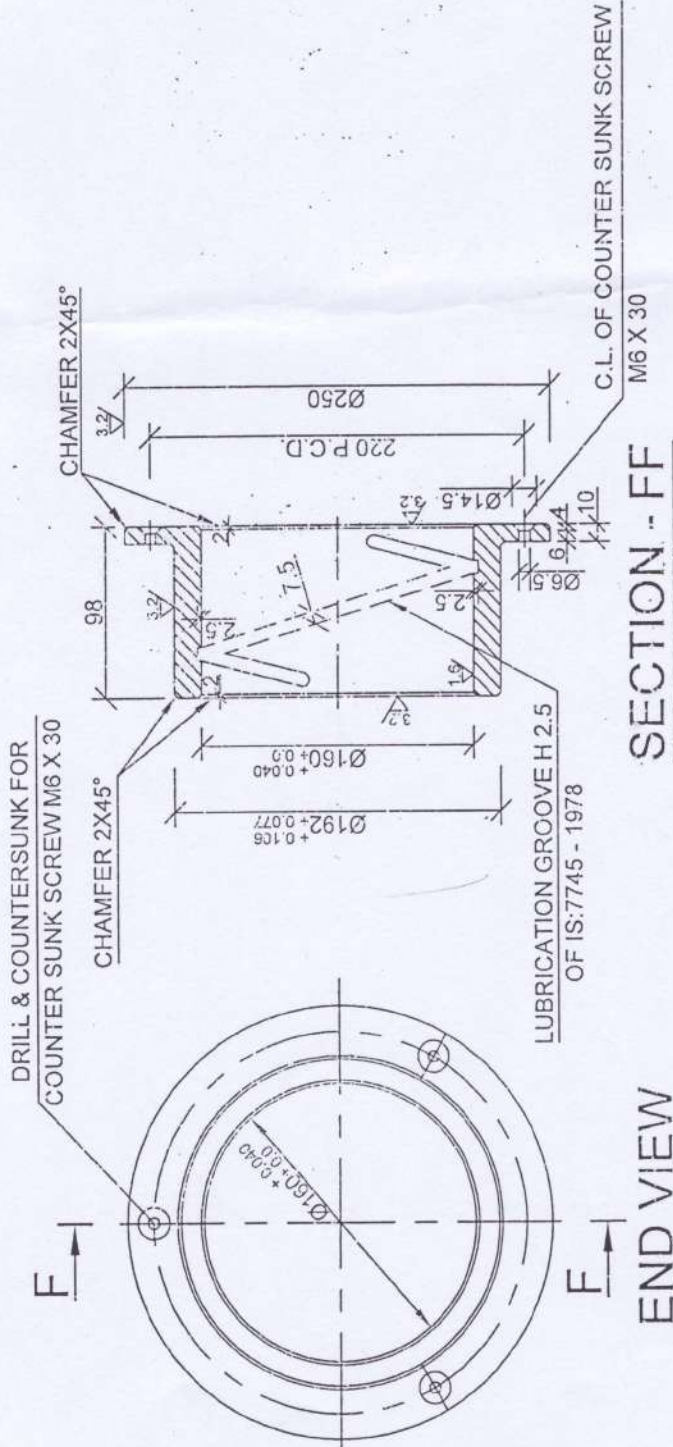

SECTION - FF

END VIEW

BUSH FOR PULLEY

PART NO.- 05-12-05-00-04-06
 MATERIAL - LTB - 1 OF IS:318-1931
 TOTAL NOS. REQD. = 8 (EIGHT)

REF.DRG.

1.05-12-05-00-04

NOTES:-

1. ALL DIMENSIONS ARE IN mm OF THE FINISHED PART.
2. SUITABLE MACHINING ALLOWANCES (NOT LESS THAN 5 mm ON TOOL POINT) SHALL BE PROVIDED ON ALL SURFACES INDICATED TO BE MACHINED.
3. THE FINISHES AND TOLERANCES GIVEN ARE FOR THE FINISHED PART ONLY.
4. DRILL & TAP FOR COUNTER SUNK SCREW M6 X 30 SHALL BE DONE ALONG WITH THE MATCHING PART.

TELENGIRI IRRIGATION PROJECT

35 T GANTRY CRANE FOR SPILLWAY STOPLOG

BUSH FOR PULLEY

O.C.C.LTD.

DRAWN	<i>Rajaram</i>
CHECKED	<i>Chandrababu</i>
SUBMITTED	<i>[Signature]</i>
APPROVED	<i>[Signature]</i>

JULY 2021

DRG.NO.- 05-12-05-01-04-06