

**ODISHA CONSTRUCTION CORPORATION LTD.
(A GOVT. OF ODISHA UNDERTAKING)
CENTRAL WORKSHOP, RASULGARH,
BHUBANESWAR-751010 (ODISHA)**

**TENDER DOCUMENT FOR
“SUPPLY OF TRUNNION SEALS REQUIRED FOR SPILLWAY GATE OF
DEO IRRIGATION PROJECT”**

The tender document comprises of the following:

1)	Tender call notice No.OCC/CWS/PROC/DEP-03/ 17/19-20 dated 29.08.2019	01 (One) sheet
2)	Terms and conditions	04 (Four) sheets
3)	Drawing	01 (Six) sheets
4)	Price schedule	01 (One) sheet

	Total:	07 (Seven) sheets

Signature of the Job Worker agency or
His/their Power of attorney holder
with designation & seal.

Senior Manager (Mech.)-I
OCC Ltd, Central Workshop,
Rasulgarh, Bhubaneswar-10.

**ODISHA CONSTRUCTION CORPORATION LIMITED
(A GOVT. OF ODISHA UNDERTAKING)
CENTRAL WORKSHOP: RASULGARH,
BHUBANESWAR-751010 (ODISHA)**

Tender Call Notice No. OCC/CWS/PROC/DEP-03/17/19-20 Dtd.29.08.2019

Sealed tenders in conformity with the term & conditions, drawings and specifications in tender documents are invited from reputed manufacturers / authorized traders for **"SUPPLY OF TRUNNION SEALS REQUIRED FOR SPILLWAY GATE OF DEO IRRIGATION PROJECT"** as per details below:

Cost of tender document (Non-refundable)	Sale of tender Document		Earnest money deposit (EMD) required	Receipt & opening of technical bid of tender	Opening of price schedule bid of tender
` 400/- GST @ 12% ` 448/- by hand. & ` 548/- by Regd. Post/ courier	From 30.08.2019	To 10.09.2019 up to 1.00 PM	1(One)% of the total quoted value	Up to 3.00 PM & 4.00 P.M. on 10.09.2019	At 4.00 PM on 10.09.2019

The tender document can be purchased by the interested reputed manufacturers / traders by hand from the office of the undersigned on deposit of cost of tender document i.e. `400/- plus GST @ 12% amounting to `448/- in cash or in shape of A/c. payee demand draft drawn in favour of "Odisha Construction Corporation Limited- Project Account" on any Nationalised Bank/ Scheduled Bank payable at Bhubaneswar (Non-refundable) and production of attested copies of the following documents and verification thereof by the undersigned. The tender document can also be obtained by the interested reputed manufacturers / traders by registered post, speed post/ courier on sending the cost of tender document i.e. `400/- plus GST @ 12% and postage charges of `100/- amounting to `548/- in shape of A/c. payee demand draft drawn as stated above and attested copies of the following documents and verification thereof by the undersigned. The undersigned will not be responsible for any kind of delay by the postal/courier authorities.

- 1) Valid GST registration certificate
- 2) PAN Card
- 3) Credentials in support of supply of similar items of similar magnitude and satisfactory performance thereof.
- 4) Authorised distributorship/stockist/dealership certificate, if not a manufacturer

The tender document can also be downloaded from our Website www.odishaconstruction.com to submit the tender (**Bidders are requested to visit our website regularly for any changes since it will not be published in news paper again**). However, the cost of tender document i.e. `400/- plus GST @ 12% amounting to `448/- in shape of A/c payee demand draft as stated above in favour of "Odisha Construction Corporation Limited- Project Account" on any Nationalised Bank/ Scheduled Bank payable at Bhubaneswar (Non-refundable) along with attested photo copies of all above documents should be submitted while submitting the tender in Envelope-I. Otherwise, the tender will be cancelled. OCCL will not be responsible for missing of any page while downloading. If there will be a public holiday on the last date of sale of tender document and receipt & opening of the tender as specified above, the tender document will be sold and tender will be received & opened on the next working day at the same time and venue.

The SSI/NSIC/MSME units participating in tender are not entitled for exemption from payment of EMD/ Security Deposits/ Tender Paper costs as communicated vide DOWR Letter No. IIM-24/2018-14318/WR dated 24.05.2018 & Head Office, OCCL Letter No.5502/OCC/ CW-02/09(Vol-V)(WE) dated 30.05.2018.

The tenders will be opened in the presence of the tenderers or their authorised representatives. Tender through Fax/Telex/telegram/e-mail will not be accepted

The undersigned reserves the right to accept or reject any or all quotations without assigning any reason thereof.

Signature of the Job Worker agency or
His/their Power of attorney holder
with designation & seal.

Senior Manager (Mech.)-I
OCC Ltd, Central Workshop,
Rasulgarh, Bhubaneswar-10.

**ODISHA CONSTRUCTION CORPORATION LTD.
(A GOVT. OF ODISHA UNDERTAKING)
CENTRAL WORKSHOP, RASULGARH,
BHUBANESWAR-751010 (ODISHA)**

**TERMS AND CONDITIONS OF TENDER FOR
“SUPPLY OF TRUNNION SEALS REQUIRED FOR SPILLWAY GATE OF
DEO IRRIGATION PROJECT”**

1. Reputed manufacturers/ authorized traders having supplied similar items of similar magnitude earlier and satisfactorily accepted by the clients will be eligible to participate in the tender. The copies of purchase orders, credentials, certificates etc. in support of similar supply and satisfactory performance thereof will be furnished along with the tender.
2. The tenderer should submit Earnest Money Deposit (EMD) @ 1% of the total quoted value along with the tender in shape of Account payee demand draft drawn in favour of “Odisha Construction Corporation Ltd-Project account” on any Nationalised bank/ scheduled bank payable at Bhubaneswar. The tenders received without EMD will be out rightly rejected. EMD of the unsuccessful tenderers will be released only after finalization of the tender.
3. Tender should be submitted in two bid system in two separate sealed covers and both will be submitted in a single sealed outer cover subscribing in bold letters as “**TENDER FOR SUPPLY OF TRUNNION SEALS REQUIRED FOR SPILLWAY GATE OF DEO IRRIGATION PROJECT**” and also the date of opening of tender. The name and address of the tenderer should not be written on outer cover. Only the name and address of the purchaser should be written on the outer cover.
4. i) The first envelope super scribing in bold letters as “**TECHNICAL BID**” should contain the following:
 - a. EMD of 1% as per clause- 2 above.
 - b. Attested copy of valid GST registration certificates. The tenderer will mention his GSTIN in his tender clearly without which the tender will not be taken into consideration.
 - c. Attested copy of PAN Card.
 - d. Attested copies of purchase orders, credentials, certificates in support of similar supply and magnitude and satisfactory performance thereof.
 - e. Complete tender document in original including terms and conditions but without detailed specifications and price schedule duly signed on each page by the tenderer or his power of attorney holder. In case of power of attorney holder, the attested copy of power of attorney should be furnished.
- ii) Second envelope subscribing in bold letters “**SPECIFICATION AND PRICE SCHEDULE**” should contain detailed specifications and price schedule in original only duly filled in without leaving any column and line blank and signed on each page by the tenderer or his power of attorney holder.

Signature of the Job Worker agency or
His/their Power of attorney holder
with designation & seal.

Senior Manager (Mech.)-I
OCC Ltd, Central Workshop,
Rasulgarh, Bhubaneswar-10.

5. The tender document can be purchased by the interested reputed manufacturers/ authorized traders by hand from the office of the undersigned from **30.08.2019** to **10.09.2019** (up to **1.00 PM**) during office hours on deposit of cost of tender document i.e. ` .400/- plus GST @ 12% amounting to ` .448/- in cash or in shape of A/c. payee demand draft drawn in favour of “Odisha Construction Corporation Limited-Project account” on any nationalized bank/ schedule bank payable at Bhubaneswar (non-refundable) and production of attested copies of the following documents and verification thereof by the undersigned. The tender document can also be obtained by the interested reputed manufacturers/ authorized traders by registered post / courier on sending the cost of tender document i.e. ` .400/- plus GST @ 12% plus postage charges of ` 100/- amounting to ` .548/- in shape of A/c. Payee demand draft drawn in favour of “Odisha Construction Corporation Limited – Project account” on any nationalized bank/schedule bank payable at Bhubaneswar (non-refundable) and sending attested copies of the following documents and verification thereof by the undersigned.
 - a. Valid GST Registration Certificates.
 - b. PAN Card
 - c. Credentials in support of supply of similar items of similar magnitude and satisfactory performance thereof.
 - d. Authorised distributorships/ stockists/ dealership certificate, if not a manufacturer.
6. The tender document can also be downloaded from our Website www.odishaconstruction.com to submit the tender (**Bidders are requested to visit our website regularly for any changes since it will not be published in news paper again**). However, the cost of tender document i.e. ` .400/- plus GST @ 12% amounting to ` .448/- in shape of A/c payee demand draft as stated above in favour of “Odisha Construction Corporation Limited- Project Account” on any Nationalised Bank/ Scheduled Bank payable at Bhubaneswar (Non-refundable) along with attested photo copies of all above documents should be submitted while submitting the tender in Envelope-I. Otherwise, the tender will be cancelled. OCCL will not be responsible for missing of any page while downloading.
7. The tenders will be received up to **3.00 PM** on **10.09.2019** and **TECHNICAL BID** will be opened in the office of the undersigned on the same day at **3.30 PM** in presence of the tenderers or their authorized representatives, if they so desire. If there will be a public holiday on the last date of sale of tender document and receipt & opening of the tenders as specified above, the tender document will be sold and tenders will be received & opened on the next working day at the same time and venue.
8. The undersigned will not be responsible for any kind of delay by the postal/courier authorities.
9. The **PRICE SCHEDULE BID** will be opened on **10.09.2019** at **4.00 PM**. Then the documents in the first envelope submitted by the tenderers will be scrutinized preliminarily on the spot. The second envelope of the valid eligible tenders after preliminary scrutiny of the documents in the first envelope will be opened on the same day immediately subject to fulfilling the requirements mentioned in the tender schedule.

Signature of the Job Worker agency or
His/their Power of attorney holder
with designation & seal.

Senior Manager (Mech.)-I
OCC Ltd, Central Workshop,
Rasulgarh, Bhubaneswar-10.

10. Rubber seals shall be strictly as per IS: specification and size as mentioned in the drawing and price schedule format enclosed to the tender schedule.
11. Original test certificate of materials confirming to relevant IS: specification and grade for physical property will be provided by the successful tenderer from Govt./Govt. approved testing laboratory along with supply of materials. The purchaser is having the option to test the materials in any laboratory at the cost of the supplier and if the materials are not found in accordance with the BIS specifications and size, the materials will be rejected.
12. The materials shall be inspected at the time of receipt at OCCL store, Central Workshop, Rasulgarh, Bhubaneswar. If the materials are not found in accordance with proper IS specifications and drawings, the same shall be out rightly rejected.
13. The materials will be guaranteed by the supplier against any defect for a period of 18 months from the date of supply or 12 months from the date of use, whichever is earlier. Guarantee certificate in this regard will accompany with supply of materials. If any defect is found in the materials within the guarantee period, the same will have to be replaced free of cost by the supplier within a suitable time fixed by the purchaser.
14. The tenderer will quote their rates F.O.R. OCCL Store, Central Workshop, Rasulgarh, Bhubaneswar-10 (Odisha) indicating separately the basic price & packing, forwarding, transportation, transit insurance, handling charges & taxes, duties, levies etc. strictly in the detailed specifications and price schedule format in original. All columns and lines of the price schedule should be filled in properly without leaving any thing blank. The details and rates of duties and taxes should be indicated clearly in the price schedule. **After finalization of tender, the quantity of rubber seals to be ordered may increase / decrease as per decession of the purchaser.**
15. The tenderer should quote appropriate taxes with the offer.
16. 90% payment will be made within 30 (Thirty) days of receipt, verification and acceptance of the complete materials along with bill, test certificate, guarantee certificate and other documents. Balance 10% payment shall be released within 30 (Thirty) days from the date of receipt of materials at store, OCCL, Central Workshop, Rasulgarh, Bhubaneswar. No advance payment shall be made under any circumstances.
17. Price escalation will not be allowed under any circumstances. The quoted rates will remain firm till execution of the work order.
18. The validity of the offer should be for a period of 120 (One hundred twenty) days from the date of opening of the tender.

Signature of the Job Worker agency or
His/their Power of attorney holder
with designation & seal.

Senior Manager (Mech.)-I
OCC Ltd, Central Workshop,
Rasulgarh, Bhubaneswar-10.

19. The complete ordered quantity is to be supplied within 30 (Thirty) days from the date of issue of the purchase order, failing which the order is liable for cancellation without assigning any reason thereof by the purchaser. In case of cancellation of the order the EMD will be forfeited. In case of any delay in supply of materials beyond the delivery schedule, supplier shall be liable to pay L.D. @ 0.5% (Half percent) of the total ordered value per week of delay or part thereof subject to Max^m of 5% (Five percent) of the total ordered value. Thereafter, the order may be cancelled with the discretion of purchaser.
20. Conditional offers with deviations will not be accepted. Those, who do not agree to the terms and conditions regarding payments, delivery and others, need not quote.
21. The authority reserves the right to accept/reject any or all quotations without assigning any reason thereof.
22. Tender through fax/telex/telegram/e-mail will not be accepted.
23. Any dispute arising out of this tender or order thereof is to be settled in proper court under the jurisdiction of Odisha High Court at Cuttack or courts under the jurisdiction of Odisha High Court at Bhubaneswar only.

Signature of the Job Worker agency or
His/their Power of attorney holder
with designation & seal.

Senior Manager (Mech.)-I
OCC Ltd, Central Workshop,
Rasulgarh, Bhubaneswar-10.

**ODISHA CONSTRUCTION CORPORATION LIMITED
(A GOVT. OF ODISHA UNDERTAKING)
CENTRAL WORKSHOP:RASULGARH,
BHUBANESWAR-751010 (ODISHA)**

SPECIFICATION & PRICE SCHEDULE

“SUPPLY OF TRUNNION SEALS REQUIRED FOR SPILLWAY GATE OF DEO IRRIGATION PROJECT”

VIDE TCN No. OCC/CWS/PROC/DEP-03/17/19-20 Dtd. 29.08.2019 DUE ON 10.09.2019.

Sl. No.	Part No.	Description of item	Quantity required in Nos.	Rate per each in Rupees					Total amount in Rupees for full quantity	
				Basic Price per each	P & F, transportation, transit insurance etc.	GST as applicable	Total in figures	Total in words	In figures	In words
1	10-12	Trunnion seals (As per drawing)- Nylon reinforced rubber	20							

*Signature of the quotationer or his/their
Power of attorney holder
with designation & seal.*

*Senior Manager (Mech.)-I
OCC Ltd, Central Workshop,
Rasulgarh, Bhubaneswar-10.*

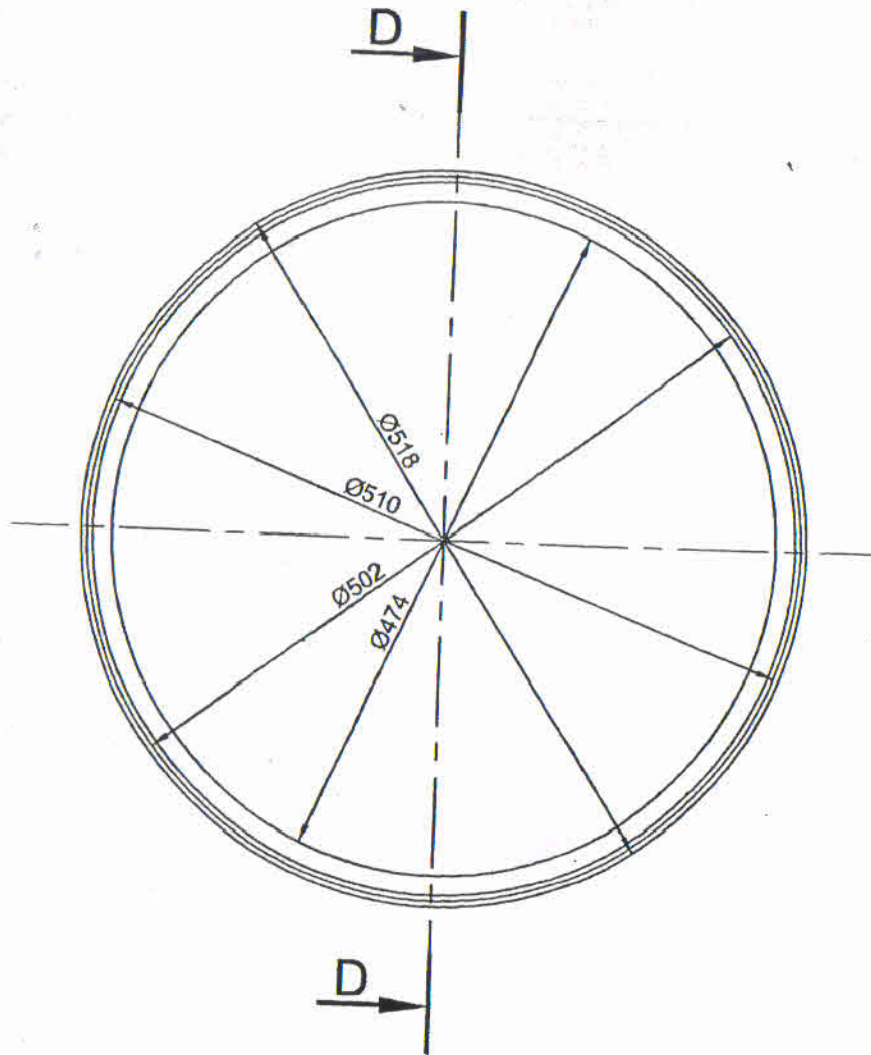

TRUNNION SEAL (10-12)

MATERIAL :- NYLON REINFORCED RUBBER

TOTAL QTY - 20 (TWENTY) NOS.

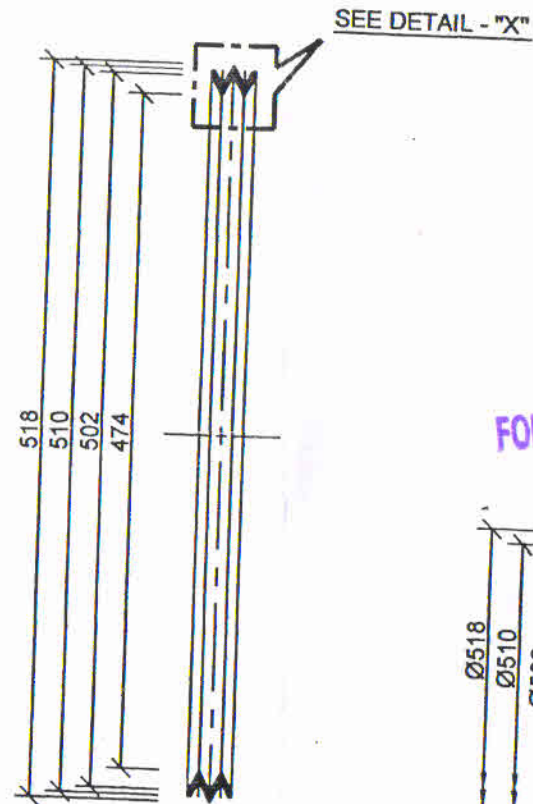

SECTION D-D

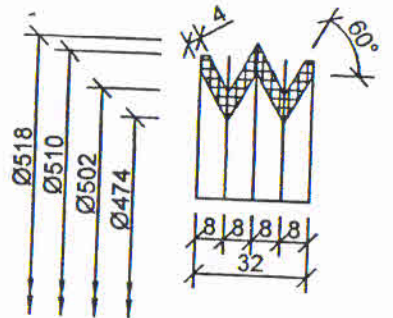

DETAIL - "X"

Dakanta
 Senior Manager (M)
 OCC Ltd., Central Workshop
 Rasulpur, Bhubaneswar-75

FOR TENDER PURPOSE ONLY

DEO IRRIGATION PROJECT
 (SPILLWAY GATE)
 OCCL